

FD50/60/70Z

DIESEL FORKLIFT

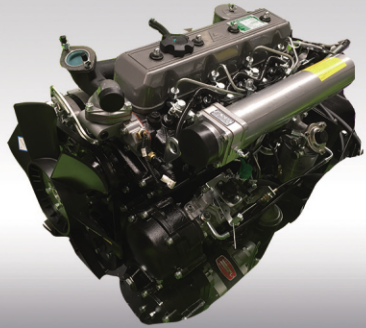

DIESEL FORKLIFT



Engine is with large torque and capacity, which is powerful and can meet different operation demands;



Integrated overhead guard is adopted. The canopy is one-time stamping part with 5 pieces transparent plastic cover, which receives sufficient light and keeps rain out;

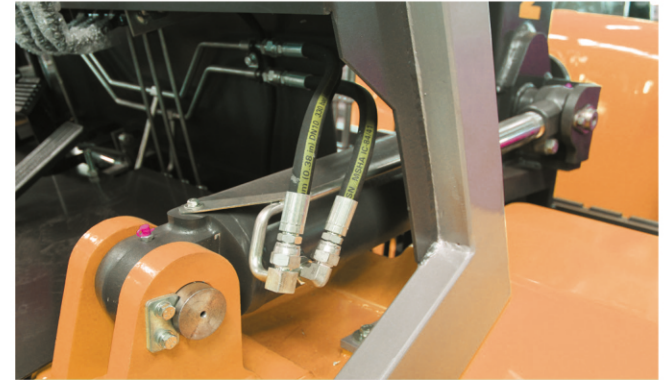

Hydraulic system is equipped with the throttling valve, which makes operation safe and reliable;



Reinforce mast with wide view design improves efficiency and safety meanwhile enhances anti-forde capacity;



Scientific ergonomic design makes more portable and comfortable. Seat and backrest are adjustable;



Steering wheel tilt angle is also adjustable, which leaves more legroom. The portable gearshift is quick to shift and easy to operate;

Machine Parameters

Features		FD50Z	FD60Z	FD70Z
Power	—	Diesel	Diesel	Diesel
Rated Capacity	kg	5000	6000	7000
Center of load	J(mm)	600	600	600
Lifting height	h1 (mm)	3000	3000	3000
Free lifting height	h3(mm)	203	208	218
Forks L×W×H	L5×W×T(mm)	1220×150×55	1220×150×60	1220×150×70
Tilt Forward/Backward	-	6/12	6/12	6/12
Min.turning radius	R1(mm)	3320/3415(Xichai 6110)	3420/3507 (Xichai 6110)	3420/3507(Xichai 6110)
Min right angle stalking width	Ra(mm)	5550/5645(Xichai 6110)	5655/5742 (Xichai 6110)	5665/5752(Xichai 6110)
Min.ground clearance(Mast)	m(mm)	200	200	200
Overhead guard height	h4(mm)	2460	2460	2460
Front overhang	L3(mm)	610	615	625
Rear overhang	L4(mm)	566	692	692
Performance				
Max.traveling speed(loaded)	km/h	26	26	26
Max.lifting speed(loaded/empty)	mm/s	370/450	370/450	350/450
Drawbar pull/Gradeability	kN/%	51.4/20	51.4/20	51.4/20
Size				
Overall length with fork	L1 (mm)	4646 /4736(Xichai 6110)	4677//4767 (Xichai 6110)	4687/4777(Xichai 6110)
Overall width	W1 (mm)	2000	2000	2000
Mast lowered height	h2(mm)	4417	4417	4417
Mast extended height	mm	2500	2500	2500
Chassis				
Tire(Front)	—	8.25-15-14PR	8.25-15-14PR	8.25-15-14PR
Tire(Rear)	—	8.25-15-14PR	8.25-15-14PR	8.25-15-14PR
Wheelbase	L2(mm)	2250/2340 (Xichai 6110)	2250/2340 (Xichai 6110)	2250/2340 (Xichai 6110)
Tread width(Front/Rear)	S/P(mm)	1470/1700	1470/1700	1470/1700
Curb weight(None-load)	kg	7980	8640	9340
Engine				
Battery(Voltage/Capacity)	V/Ah	(12/90)x2	(12/90)x2	(12/90)x2
Engine type	—	Xichai CA4DF3	Xichai CA4DF3	Xichai CA4DF3
Rated power	kw	85/2200	85/2200	85/2200
Rated torque	kw	460/1400-1500	460/1400-1500	460/1400-1500
Displacement	L	4.75	4.75	4.75

2-Stage Standard Mast / 2-Stage Full Free Mast

Lifting height	Coading capacity			Mast lowered height		Free lifting height with backrest			Masttilt Angle f/r
	5T	6T	7T			5T	6T	7T	
mm	kg	kg	kg	mm	mm	mm	mm	mm	°
3000	5000	6000	7000	2500 *2560	4417 *4426	203 *1189	208 *1193	218 *1204	6/12
3500	5000	6000	7000	2750 *2810	4917 *4926	203 *1439	208 *1443	218 *1454	6/12
4000	5000	6000	6800	3050 *3110	5417 *5426	203 *1739	208 *1743	218 *1754	6/12
4500	4800	5800	6600	3300 *3360	5917 *5926	203 *1989	208 *1993	218 *2004	6/6
5000	4600	5500	6300	3550 *3610	6417 *6426	203 *2239	208 *2243	218 *2254	6/6
5500	4500	5400	6200	3850 *3910	6917 *6926	203 *2539	208 *2543	218 *2554	3/6
6000	4400	5200	6000	4100 *4160	7417 *7426	203 *2789	208 *2793	218 *2804	3/6

3-Stage Full Free Mast

Lifting height	Coading capacity			Mast lowered height		Free lifting height with backrest			Masttilt Angle f/r
	5T	6T	7T			5T	6T	7T	
mm	kg	kg	kg	mm	mm	mm	mm	mm	°
4000	4800	5800	6800	2475	5420	1104	1108	1118	6/6
4350	4500	5500	6500	2590	5767	1219	1223	1233	6/6
4800	4500	5500	6500	2740	6217	1369	1373	1383	6/6
5000	4500	5500	6500	2805	6410	1434	1438	1448	6/6
6000	4000	5000	6000	3190	7410	1819	1823	1833	3/6

Capacity Chart

Load table: 5t-7t

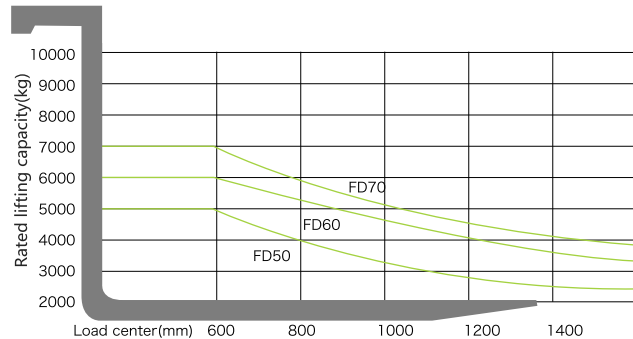

Machine 2D Graph

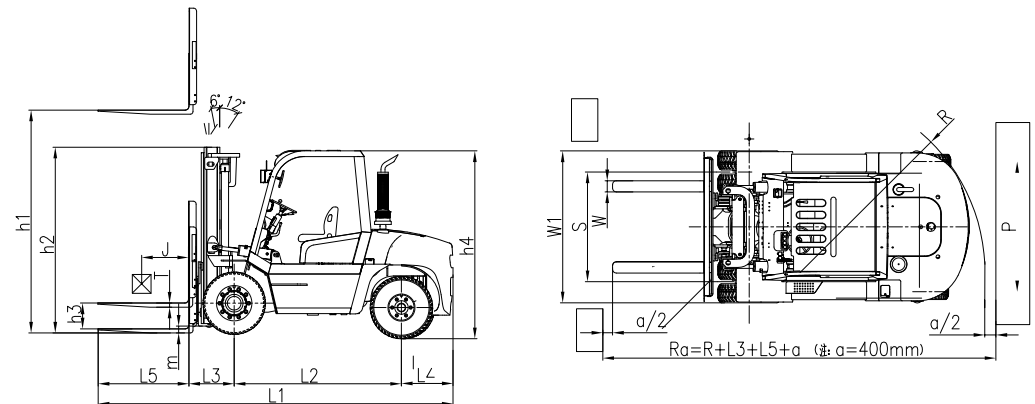

Standard Equipment

Wideview mast	Timer	Hydraulic oil return filter
Standard fork	Parking brake	Hydraulic oil intake filter
Standard seat	Lifting & tilting handle	Hydraulic oil level gauge
Backrest	Speed limit valve	Oil pressure indicator
Reversing light	Traction pin	Key switch
Reversing buzzer	Headlamp	Service brake
Rearview mirror	Adjustable steering wheel	Turning signal
Light switch	Tilt oil passage self-locking valve	Toolbox
Overhead guard	Hydraulic powered steering	Lamp holder
Electric Horn	Handle	Neutral indicator
2 piece multi valve	Water temperature gauge	Tornado air filter
Rear lamp	Metal pedal pad	
Durable pneumatic tire	Combined instrument panel	

Options

Windshield	Optional painting
Two/three stage full-free mast	High exhaust
Cab	Exhaust smoke purification muffler
Heater	
Fire extinguishing muffler	
Solid tyre	
Rotary work alarming light	
Mini fan	
File clip	
Oil-bath double filter(on overheadguard)	
Fire extinguisher	
Tilt cylinder dust cover	

Engine selection table

TYPE	Rated power (kW/r.p.m)	Maximum torque (N · m/r.p.m)	Displacement (L)
-			
ChaoChai CY6BG332(6缸)	85/2200	450/1400-1600	5.785
WeiChai WP4.1	85/2300	460/1400-1600	4.09

Attachment

- Side shifter
- Fork positioner
- Hinged fork
- Carpet boom
- Extended fork
- Fork cover
- Lifting boom
- Paper roll clamp
- Extended Lift Bracket
- Bale clamp
- Rotator
- Barrel clamp
- Hook



M

ZOOMLION ANHUI INDUSTRIAL VEHICLE CO.,LTD

Add: No.2 Nanwei Road,Area of High-tech Development Zone,Wuhu,Anhui Province,China
Post: 241002 TEL: +86-553-3020328 Website: www.zoomlion.com

All information based at the time of printing and subject to change without notice.
Pictures may be shown with optional equipment. All rights reserved.

