

ZOOMLION

ZTC1000V753 Manual do Operador para Guindaste de Caminhão

Edição de 1 de julho de 2021

Aos Usuários

A Zoomlion agradece a sua seleção de guindaste de caminhão ZOOMLION para sua aplicação.

Ninguém deve operar o guindaste a menos que leia e entenda as informações deste manual.

Este manual contém as instruções e dados sobre a segurança e operação do caminhão guindaste. Siga os procedimentos de operação para garantir que sua máquina funcione com a MÁXIMA EFICIÊNCIA. O operador deve manter este manual na cabine do guindaste.

Se houver algo no manual que não esteja claro ou que você não entenda, entre em contato com nosso técnico de serviço. Nós (Zoomlion) NÃO somos responsáveis por danos de um operador que não obedece às instruções do *MANUAL DO OPERADOR*.

O *MANUAL DO OPERADOR* é uma parte importante do guindaste. Se o guindaste se tornar propriedade de outra pessoa, certifique-se de que o manual permaneça na cabine do guindaste. Os dados (dados, especificações, ilustrações) neste manual são para guindastes em produção no momento da publicação deste manual. Reservamo-nos o direito de fazer alterações neste manual a qualquer momento, sem obrigação.

O manual foi traduzido para ser o melhor de nosso conhecimento. A Zoomlion não assume nenhuma responsabilidade por erros de tradução. A versão chinesa do *MANUAL DO OPERADOR* é aplicável apenas para precisão factual.

Obrigado!

Mobile Crane Branch Company da Zoomlion Heavy Industry Science and Technology Co., Ltd.

Copyright [Direitos Autorais]

De acordo com as leis de direitos autorais, este manual não pode ser copiado, fotocopiado, reproduzido, traduzido ou reduzido a qualquer meio eletrônico ou forma legível por máquina, no todo ou em parte, sem o consentimento prévio por escrito da Zoomlion Heavy Industry Science and Technology Co., Ltd.

Copyright © 20XX, Zoomlion Heavy Industry Science and Technology Co., Ltd. Todos os direitos reservados.

Instruções de Segurança

As etiquetas de PERIGO, ADVERTÊNCIA, CUIDADO e AVISO estão em placas e adesivos, e conforme você lê este manual para mostrar instruções importantes. Neste manual, as etiquetas seguem o parágrafo ou item a que se aplicam. Os marcadores são os seguintes:



Refere-se a uma situação perigosa que, se você não prevenir, causará morte ou ferimentos.



Refere-se a uma possível situação perigosa que, se você não prevenir, poderia causar morte ou ferimentos.



Refere-se a uma possível situação perigosa que, se você não prevenir, pode causar ferimentos leves ou moderados.



Refere-se a uma situação que, se você não prevenir, pode causar danos à propriedade ou ao equipamento.

Conteúdo

Para Usuários	I
Instruções de Segurança.....	II
Capítulo 1 Descrição do Guindaste	
1.1 Modelos e placas de identificação	1-1
1.1.1 Modelos	1-1
1.1.2 Placas de identificação.....	1-1
1.1.3 Locais de instalação das placas de identificação	1-2
1.1.4 Número de identificação do veículo (VIN) e suas localizações.....	1-3
1.1.5 Modelo e fabricante do motor	1-3
1.1.6 Código do motor, placa de identificação e suas localizações	1-3
1.2 Componentes do guindaste e descrição do produto	1-5
1.2.1 Componentes do guindaste	1-5
1.2.2 Descrição do produto	1-7
1.2.3 Lança	1-9
1.3 Dados técnicos.....	1-11
1.3.1 Visão geral.....	1-11
1.3.2 Dispositivos de proteção	1-12
1.3.3 Dados técnicos	1-13
1.3.4 Parâmetros de trabalho.....	1-17
1.3.5 Tabelas de capacidade de elevação	1-18
1.3.6 Tabelas de altura de elevação	1-115
1.3.7 Áreas de trabalho	1-120
Capítulo 2 Diretrizes de Segurança	
2.1 Instruções de segurança e sinais de segurança.....	2-1
2.1.1 Instruções de segurança	2-1
2.1.2 Sinais de segurança.....	2-1
2.2 Planejando a operação do guindaste	2-4
2.3 Instruções de amaciamento.....	2-5
2.4 Diretrizes técnicas gerais de segurança.....	2-6
2.4.1 Requisitos do operador de guindaste, armador e sinalizador	2-6
2.4.2 Selecionando um local de operação.....	2-8
2.4.3 Suporte	2-10

2.4.4 Condições de trabalho	2-11
2.4.5 Pontos de atenção para operação segura.....	2-16
2.5 Sinais manuais.....	2-19

Capítulo 3 Operação – Chassi do Guindaste

3.1 Cabine do motorista	3-1
3.1.1 Visão Geral.....	3-1
3.1.2 Montagem do volante.....	3-3
3.1.3 Montagem do instrumento.....	3-8
3.1.4 Botão da buzina a ar	3-34
3.1.5 Pedal (D): Controle do motor	3-34
3.1.6 Pedal (M): Freio de serviço	3-34
3.1.7 Pedal (E): Embreagem (não aplicável ao AMT)	3-34
3.1.8 Console central.....	3-35
3.1.9 Iluminação do guindaste	3-47
3.1.10 Porta, cabine do motorista	3-48
3.1.11 Assentos na cabine do motorista	3-50
3.1.12 Anexos.....	3-51
3.2 Antes de ligar o veículo.....	3-53
3.2.1 Pré-requisitos	3-53
3.2.2 Verificações gerais antes de partir.....	3-53
3.2.3 Verificações gerais na partida do veículo	3-59
3.3 Conduzindo o guindaste	3-61
3.3.1 Partida e parada do motor	3-61
3.3.2 Condução	3-63
3.3.3 Instrumentos de controle importantes durante a condução	3-64
3.3.4 Operação de transmissão manual	3-65
3.3.5 Operação da embreagem (não aplicável para AMT).....	3-71
3.3.6 Operação de direção.....	3-72
3.3.7 Operação do freio.....	3-72
3.3.8 Operação da tomada de força	3-74
3.3.9 Reboque	3-76
3.3.10 Terminando as operações de condução.....	3-76
3.3.11 Códigos de erro do motor e diagnóstico de falhas	3-77
3.4 Pontos de atenção	3-78
3.4.1 Condução em estrada	3-78
3.4.2 Movimentos do guindaste em condições off-road	3-79
3.4.3 Estacionar o veículo	3-80

3.4.4 Parada de emergência na rodovia	3-80
---	------

Capítulo 4 Operação – Superestrutura do Guindaste

4.1 Cabine do operador	4-1
4.1.1 Visão geral.....	4-1
4.1.2 Painel de instrumentos.....	4-2
4.1.3 Painel de interruptores	4-3
4.1.4 Interruptores e luzes do balancim	4-10
4.1.5 Caixas de controle.....	4-13
4.1.6 Pedal de controle do motor	4-17
4.1.7 Assento do operador	4-17
4.1.8 Pedal de controle do motor	4-18
4.2 Sistema de computador	4-19
4.2.1 Geral	4-19
4.2.2 Programas	4-21
4.3 Colocando o guindaste em funcionamento	4-48
4.3.1 Verificações antes de colocar em funcionamento	4-48
4.3.2 Partida e parada do motor	4-49
4.4 Dispositivos de segurança	4-50
4.4.1 Medidor de nivelamento	4-50
4.4.2 Interruptor de limite de içamento.....	4-51
4.4.3 Interruptor de limite de descida	4-53
4.4.4 Dispositivos hidráulicos de segurança.....	4-54
4.4.5 Operação de bypass	4-55
4.4.6 Sistema de aviso de velocidade do vento.....	4-56
4.4.7 Botão de parada de emergência.....	4-57
4.5 Operação do guindaste.....	4-58
4.5.1 Preparativos para operação do guindaste	4-58
4.5.2 Estabilizador	4-59
4.5.3 Derivação	4-68
4.5.4 Elevação / descida	4-70
4.5.5 Rotação	4-75
4.5.6 Movimentos simultâneos do guindaste.....	4-77
4.5.7 Passagem da corda	4-83

Capítulo 5 Equipamentos

5.1 Diretrizes técnicas de segurança para montagem.....	5-1
5.2 Braço.....	5-2
5.2.1 Geral.....	5-2
5.2.2 Montagem.....	5-2
5.2.3 Configurações de ângulo.....	5-9
5.2.4 Desmontagem.....	5-10
5.2.5 Passagem no cabo de içamento auxiliar.....	5-11
5.2.6 Conexão do interruptor de limite de içamento.....	5-11
5.3 Lança de ponta.....	5-13
5.3.1 Geral.....	5-13
5.3.2 Montagem.....	5-14
5.3.3 Configurações de ângulo.....	5-15
5.3.4 Desmontagem.....	5-16
5.3.5 Passagem no cabo de içamento.....	5-16
5.3.6 Conexão elétrica.....	5-18
5.4 Roldana de caixa aberta.....	5-19
5.4.1 Montagem.....	5-19
5.4.2 Desmontagem.....	5-20
5.4.3 Conexão do interruptor de limite de içamento.....	5-20
5.5 Extensão.....	5-21
5.5.1 Visão Geral.....	5-21
5.5.2 Montagem.....	5-21
5.5.3 Desmontagem.....	5-22
5.5.5 Passagem na extensão.....	5-23
5.5.5 Passagem na extensão e no braço.....	5-23
5.5.6 Conexão do interruptor de limite de içamento.....	5-24
5.6 Contrapeso.....	5-26
5.6.1 Contrapeso e manipulador de contrapeso.....	5-26
5.6.2 Caixa de controle remoto do contrapeso.....	5-28
5.6.3 Montagem.....	5-29

Capítulo 6 Equipamentos Adicionais

6.1 Ar condicionado na cabine do motorista.....	6-1
6.1.1 Métodos operacionais	6-1
6.2 Ar condicionado na cabine do operador	6-4
6.2.1 Ar condicionado.....	6-4
6.2.2 Aquecedor da cabine	6-6

Capítulo 7 Transporte e Armazenamento

7.1 Transporte	7-1
7.2 Armazenamento	7-2

ZOOMLION

Manual do Operador de Guindaste de Caminhão

Capítulo 1 Descrição do Guindaste



Capítulo 1 Descrição do Guindaste

1.1 Modelos e placas de identificação

1.1.1 Modelos

Modelo na indústria de engenharia: ZTC1000V

Modelo do chassi: ZLJ5540JQZV5

1.1.2 Placas de identificação

Para a placa de identificação do guindaste, consulte a Figura 1-1.

Para a placa de identificação do chassi, consulte a Figura 1-2.

O guindaste é equipado com motor WP12.375E50.

ZOOMLION		汽车起重机 GUINDASTE DE CAMINHÃO	
品牌及型号	Marca Registrada e Modelo	中联牌 ZTC1000V	
产品特征号	Código de Características do Produto	ZTC1000V753	
最大额定起重量	Capacidade de Elevação Máxima Nominal	100000	kg
发动机型号	Modelo do Motor	WP12.375E50	
发动机额定功率	Potência Nominal do Motor	276	kW
发动机最大净功率/转速	Potência Líquida Máxima/RPM do Motor	271 kW	1900 rpm
最大允许总质量	Massa Total Máxima Autorizada	54000	kg
整车整备质量	Massa de Freio Completa do Veículo	53805	kg
外形尺寸(长×宽×高)	Dimensões Gerais	15700 mm × 3000 mm × 3920 mm	
车辆识别代号	VIN	L5E6H5D4xxAxxxxxx	
出厂编号	Nº de Produção		
生产日期	Data de Produção	年(Y.)	月(M.)
制造国	País de Produção	中国	China
中联重科股份有限公司制造			
FABRICANTE: ZOOMLION HEAVY INDUSTRY SCIENCE & TECHNOLOGY CO.,LTD.			

Figura 1-1 Placas de identificação do guindaste

ZOOMLION		汽车起重机专用底盘 CHASSI DE USO ESPECIAL DE GUINDASTE DE CAMINHÃO	
品牌及型号	Marca Registrada e Modelo	中联牌 Z L J 5 5 4 0 J Q Z	
产品特征号	Código de Características do Produto	ZLJ5540JQZV5	
最大允许总质量	Massa Total Máxima Autorizada	54000	kg
整车整备质量	Massa de Freio Completa do Veículo	19570	kg
发动机型号	Modelo do Motor	WP12.375E50	
发动机额定功率	Potência Nominal do Motor	276	kW
发动机最大净功率/转速	Potência Líquida Máxima/RPM do Motor	271 kW	1900 rpm
车辆识别代号	VIN	L5E6H5D4xxAxxxxxx	
出厂编号	Nº de Produção		
生产日期	Data de Produção	年(Y.)	月(M.)
制造国	País de Produção	中国	China
中联重科股份有限公司制造			
FABRICANTE: ZOOMLION HEAVY INDUSTRY SCIENCE & TECHNOLOGY CO.,LTD.			

Figura 1-2 Placa de identificação do chassi (para transmissão manual)

ZOOMLION		汽车起重机专用底盘	
CHASSI DE USO ESPECIAL DE GUINDASTE DE CAMINHÃO			
品牌及型号	Marca Registrada e Modelo	中联牌 Z L J 5 5 4 0 J Q Z	
产品特征号	Código de Características do Produto	ZLJ5540JQZV5.1	
最大允许总质量	Massa Total Máxima Autorizada	54000	kg
整车整备质量	Massa de Freio Completa do Veículo	19570	kg
发动机型号	Modelo do Motor	WP12.375E50	
发动机额定功率	Potência Nominal do Motor	276	kW
发动机最大净功率/转速	Potência Líquida Máxima/RPM do Motor	271 kW	1900 rpm
车辆识别代号	VIN	L5E6H5D4xxAxxxxxx	
出厂编号	Nº de Produção		
生产日期	Data de Produção	年(Y.)	月(M.)
制造国	País de Produção	中国	China
中联重科股份有限公司制造			
FABRICANTE: ZOOMLION HEAVY INDUSTRY SCIENCE & TECHNOLOGY CO.,LTD.			

Figura 1-3 Placa de identificação do chassi (para uma transmissão automática)

1.1.3 Locais de instalação das placas de identificação

A placa de identificação do guindaste está instalada no lado esquerdo da cabine do operador.

A placa de identificação do chassi está instalada na viga longitudinal direita da estrutura do chassi. Para localizações exatas, consulte a Figura 1-4 e 1-5.

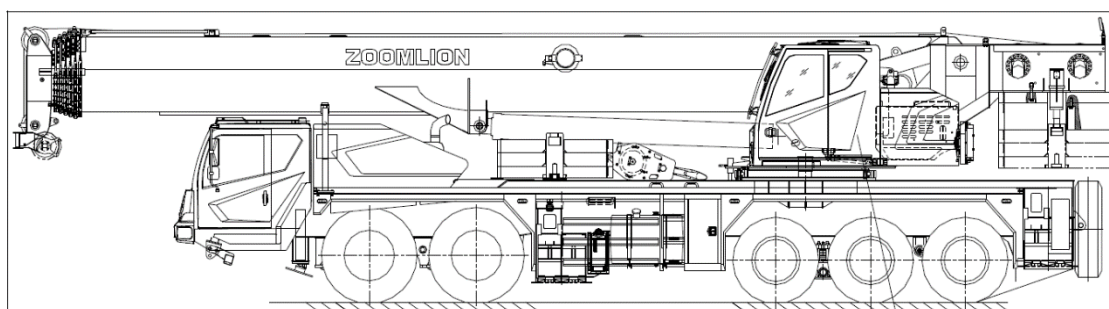

Placa de identificação do guindaste

Figura 1-4 Localização da placa de identificação do guindaste

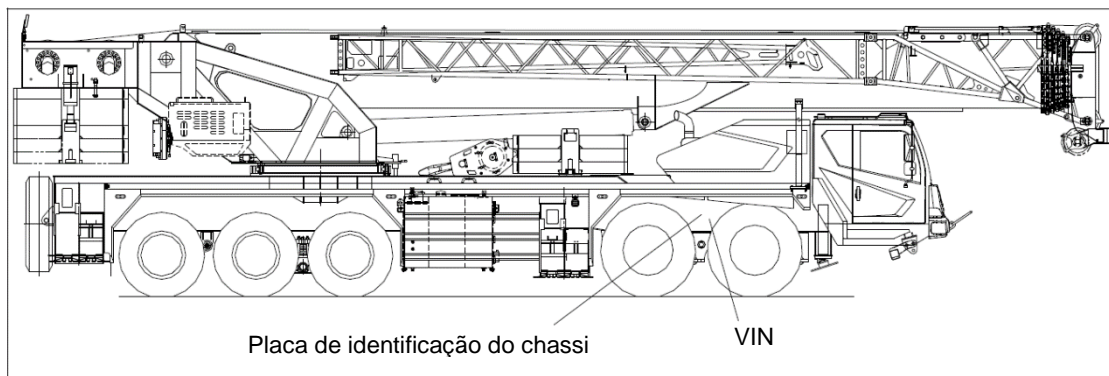

Placa de identificação do chassi VIN

Figura 1-5 Localização da placa de identificação do chassi

1.1.4 Número de identificação do veículo (VIN) e suas localizações

O VIN do ZTC1000V753 é L5E6H5D4xxAxxxxxxx, e está estampado na placa de identificação do guindaste, placa de identificação do chassi e viga longitudinal direita da estrutura do chassi.

A localização exata é mostrada na Figura 1-5.

1.1.5 Modelo e fabricante do motor

Modelo do motor: WP12.375E50

Fabricante: WEICHAI POWER Co., Ltd.

1.1.6 Código do motor, placa de identificação e suas localizações

WP12.375E50

O código do motor está estampado na parte direita do motor próximo ao plano inferior do compressor de ar (precisando raspar a pintura).

A placa de identificação do motor está instalada na parte esquerda do motor. As localizações exatas são mostradas nas Figuras 1-6 e 1-7.

Observação: Tenha os dados do motor acima disponíveis ao se comunicar conosco.



Figura 1-6 Localização do código do motor

**Figura 1-7 Localização da placa de identificação do motor**

1.2 Componentes do guindaste e descrição do produto

1.2.1 Componentes do guindaste

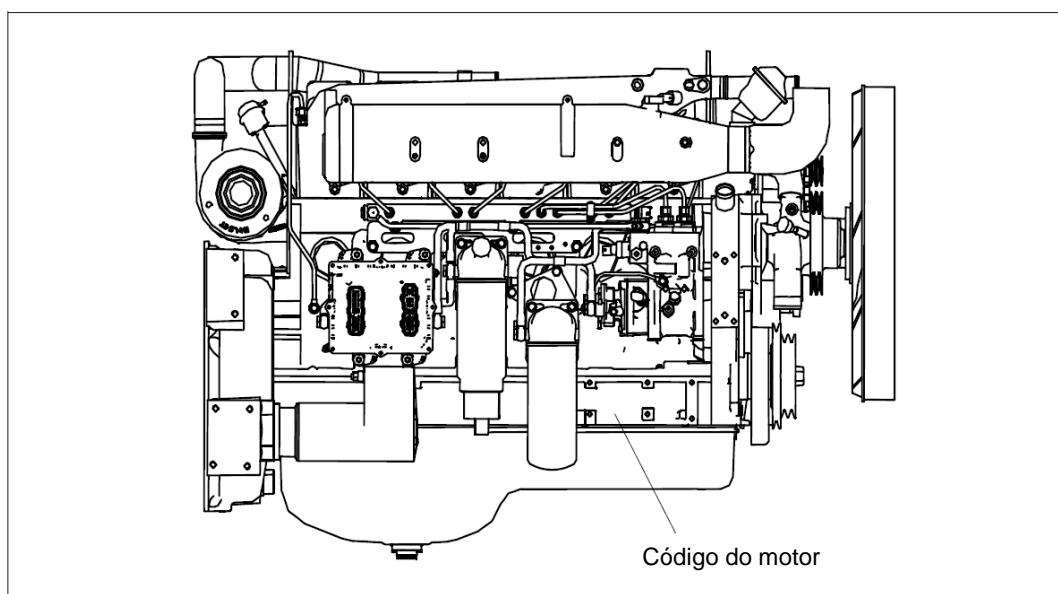
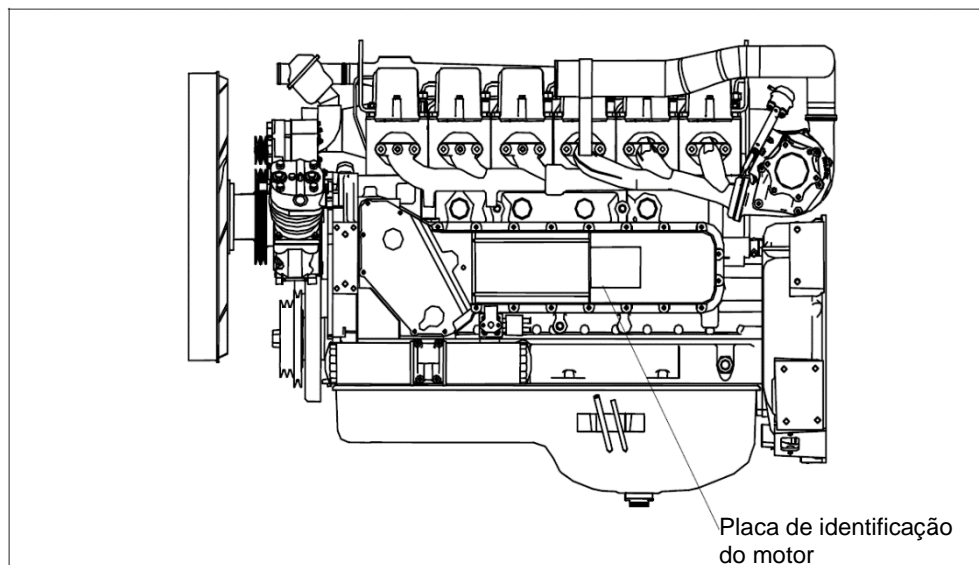
1.2.1.1 Chassi do guindaste



Figura 1-7 Principais componentes do chassi do guindaste

Pos.	Descrição	Pos.	Descrição
1	Embreagem	10	5º estabilizador
2	Sistema de exaustão	11	Caixa do estabilizador traseiro
3	Eixo dianteiro	12	Pneu reserva
4	Carcaça do motor	13	Montagem da estrutura do chassi
5	Caixa do estabilizador dianteiro	14	Eixo da hélice
6	Guarda-corpo	15	Plataforma
7	Caixa de ferramentas	16	Sistema de admissão de ar
8	Eixo intermediário	17	Embarque
9	Eixo traseiro	18	Cabine do motorista

1.2.1.2 Veículo completo

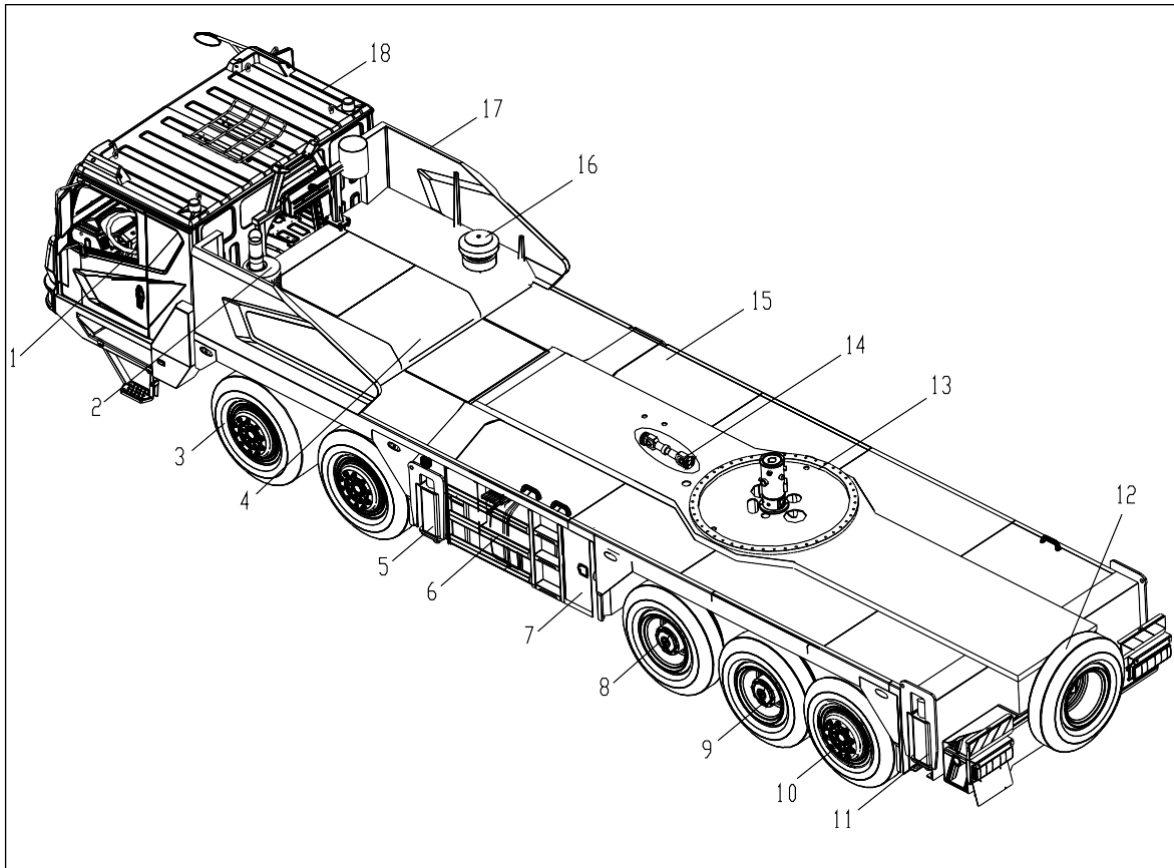

Figura 1-8 Principais componentes do veículo completo

Pos.	Descrição	Pos.	Descrição
1	Braço	8	Engrenagem de giro
2	Lança principal	9	Engrenagem da derivação
3	Indicador de comprimento	10	Gancho principal
4	Molinete auxiliar	11	Viga deslizante
5	Molinete principal	12	Gancho auxiliar
6	Contrapeso fixo	13	Chassi de uso especial
7	Cabine do operador	14	O 5º estabilizador

1.2.2 Descrição do produto

1.2.2.1 Chassi do guindaste

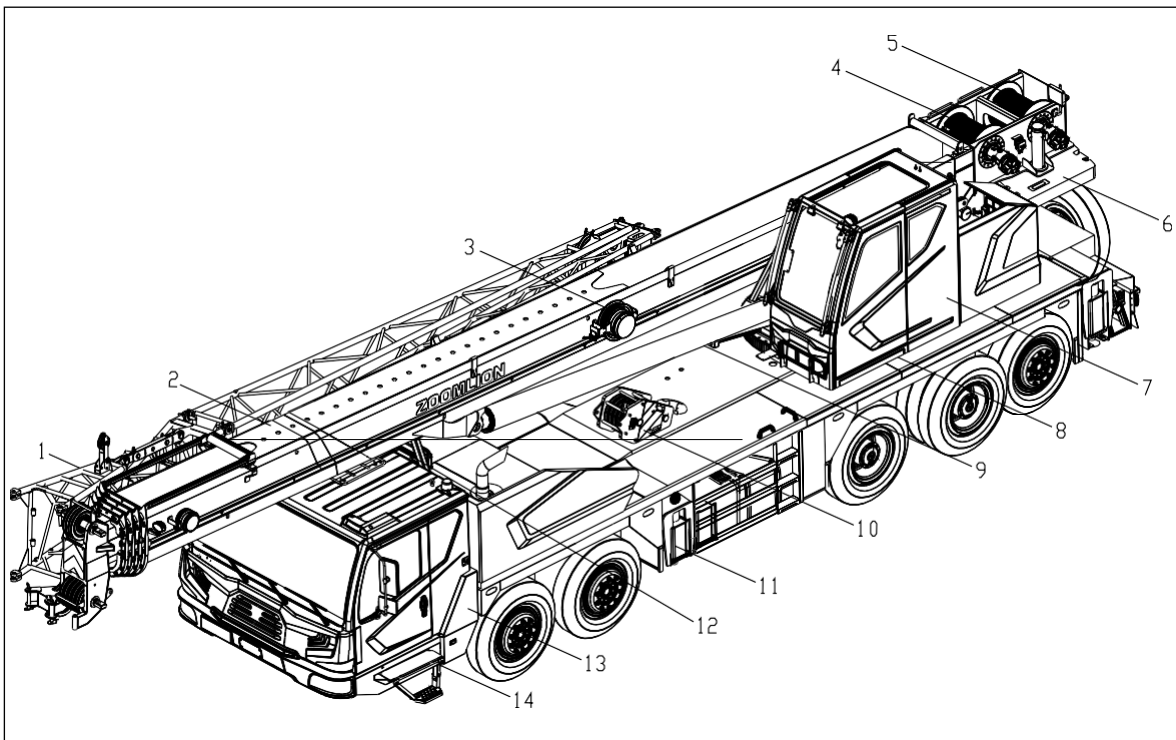
Cabine do motorista	<p>A cabine em chapa de aço de largura total baixa oferece um ambiente de trabalho confortável e funcional.</p> <p>Os elementos de controle e os displays são dispostos ergonomicamente. Assim, é garantido um trabalho seguro e sem fadiga.</p> <p>A cabine tem as seguintes características:</p> <ul style="list-style-type: none"> – Console de instrumentos montado na parte da frente – Assento acolchoado hidraulicamente com encosto superior – Para-sol e janelas operadas manualmente – Berço-cama, aquecedor de cabine e ar-condicionado – Volante ajustável em altura e posição.
Quadro do chassi	Estrutura de caixa resistente à distorção e de suporte de carga soldada em aço de alta resistência
Motor	Motor diesel de injeção de combustível eletrônica common-rail de alta pressão para fins especiais para máquinas de construção
Embreagem	Embreagem de tração monodisco tipo seco
Transmissão	<p>Transmissão mecânica de 10 velocidades com saída de engrenagem contrate</p> <p>A transmissão principal é instalada com bucha deslizante e a transmissão auxiliar é com um sincronizador de travamento de pino.</p>
Suspensão	<p>Os eixos 1 e 2 são instalados com suspensões de mola de lâmina paralelas, os eixos 3 e 4 são com mola de lâmina + viga de equilíbrio + suspensão de equilíbrio de haste de impulso e</p> <p>O eixo 5 vem com suspensão a ar guia.</p>
Rodas	<p>Aro de roda especial e pneus inflados</p> <p>385/95 R25 (Eixo 1 e 2)</p> <p>325/95R24 (Eixo 3 e 4)</p> <p>325/95R24 ou 415/80R22 (Eixo 5)</p>
Direção	Incluindo um mecanismo de direção hidráulica tipo esfera circulante integral, bomba de direção e mecanismo de acionamento de direção
Freios	<p>É composto por um freio de serviço (freio de condução), um freio de estacionamento (freio de emergência) e um freio auxiliar.</p> <p>Freio de serviço: um freio de ar comprimido de circuito duplo atuando em todos os cubos de roda</p>

Freio de estacionamento: freio acionado por mola que atua nos cubos das rodas dos eixos 2, 3 e 4.

Freio auxiliar: freio de escape do motor

Curso do pedal de freio: 95 mm

Eixo da hélice Conjunto de eixo de hélice de tipo aberto da série Styre com engrenagem contrate conectada

1.2.2.2 Superestrutura do guindaste

Cabine do operador A cabine em chapa de aço oferece um ambiente de trabalho confortável e funcional.

A cabine pode ser inclinada para trás em 20° durante a operação.

A cabine tem as seguintes características:

- Assento ajustável com apoio de cabeça
- Ar condicionado e aquecedor de cabine
- Console de instrumentos ajustável
- Joysticks operados por piloto
- Para-sol, limpador de para-brisa e sistema de lavagem.

Lança principal e sistema telescópico Lança principal de 7 seções (1 lança básica, 6 seções telescópicas)
Todas as seções da lança são telescópicas independentemente em ordem acionada por um conjunto de mecanismo de pino de cilindro único. O aço de baixa liga e alta resistência proporciona à lança uma excelente resistência à flexão.

Os blocos deslizantes integrados com tecnologia de compensação aplicada têm a capacidade de orientação e a capacidade de elevação melhoradas.

Engrenagem de derivação Um cilindro de óleo montado na parte da frente com uma válvula de equilíbrio

Engrenagem de içamento Composto por um motor hidráulico, válvula de equilíbrio do guincho, válvula de freio do guincho de unidade dupla, redutor do guincho, interruptor de limite de içamento, interruptor de limite de descida e cabo de içamento

Engrenagem de giro Composto por motor hidráulico, válvula de amortecimento de giro, redutor de giro e mancal de giro.

Sistema hidráulico Controle proporcional elétrico, com função de regulação de velocidade proporcional Acionado por uma bomba variável e uma bomba de engrenagem

Limitador de momento de carga É composto por uma unidade principal, sensor de pressão, sensor de comprimento e sensor de ângulo.
estrondo

1.2.3 Lança

Inclui a lança e os braços principais.

A lança principal inclui 1 lança básica e 6 seções telescópicas.

Comprimento da lança principal: 13,2m - 70m

Comprimento do braço: 10,4 m, 17,5 m

Quando a lança principal totalmente estendida estiver equipada com braço (3 deslocamentos: 0°, 15° e 30°), o comprimento da lança é L

= 70m+10,4m=80,4m ou L=70m+17,5m=87,5m.

Consulte a Figura 1-10.



Figura 1-10 Comprimentos da lança

Um adaptador de 9,5 m e uma extensão de 7 m são opcionais.

Quando a lança principal totalmente estendida estiver equipada com o adaptador, a extensão e o braço (deslocamento: 0°), o comprimento da lança é $L = 63,6m + 9,5m + 17,5m + 7m = 97,6m$.

Consulte a Figura 1-11.

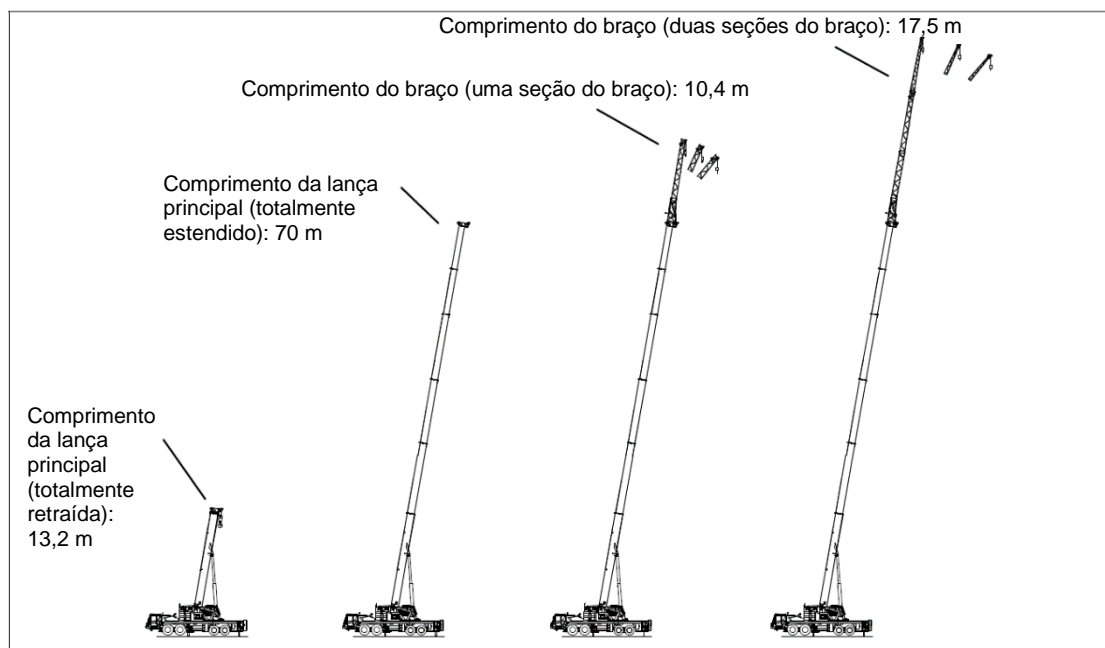

Figura 1-11 Comprimentos de lança com extensão opcional

Lança de ponta: opcional, 3,0 m

Diferentes combinações de comprimento da lança principal e da lança de ponta podem atender às suas necessidades. Consulte a Figura 1-12.

Observação: Antes de iniciar uma operação de elevação com a lança de ponta, monte-a em um deslocamento de 30°. Monte-o em um deslocamento de 0° durante a condução.

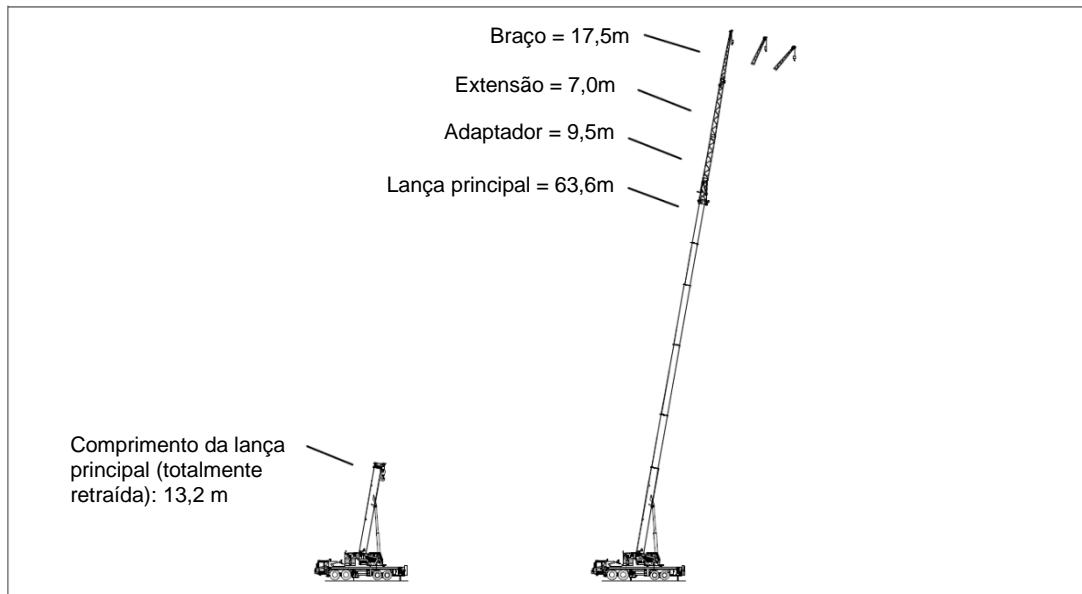

Figura 1-12 Comprimentos de lança com lança de ponta opcional

1.3 Dados técnicos

1.3.1 Visão global

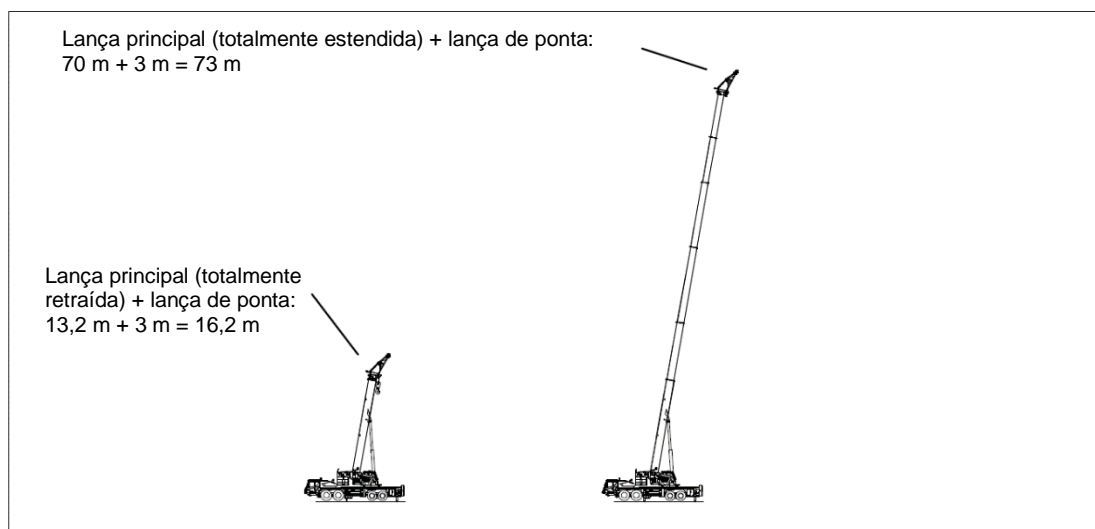

Figura 1-13 Visão geral

1.3.2 Dispositivos de proteção

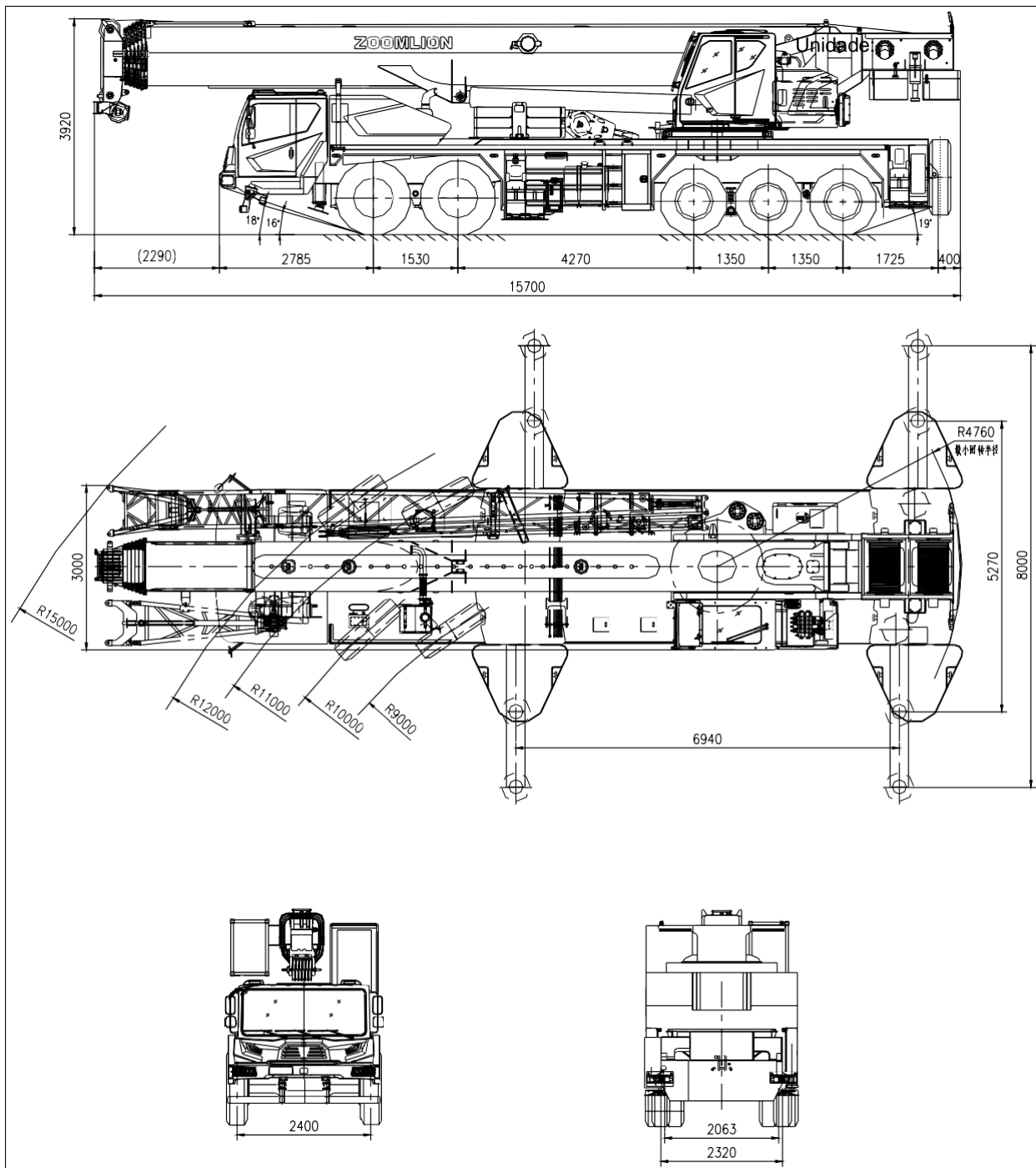

Figura 1-14 Dispositivos de proteção

1.3.3 Dados técnicos

Tabela 1-1 Dados técnicos

Item		Valor	Observações	
Desempenho no trabalho	Capacidade de elevação nominal máxima	kg	100000	
	Momento de carga máxima da lança básica	kN.m	3611	
	Momento de carga máxima da lança principal (totalmente estendida)	kN.m	1646	
	Altura máxima de elevação da lança básica	m	14,4	
	Altura máxima de elevação da lança principal (totalmente estendida)	m	70,6	
	Altura máxima de elevação com o braço instalado	m	87,8	Comprimento da lança: 70 m
	Altura máxima de elevação do braço (com extensão opcional)	m	97,8	Comprimento da lança: 63,6 m
	Velocidade máxima do cabo de içamento (molinete principal)	m/min	≤130	4ª camada do tambor
	Velocidade máxima do cabo de içamento (molinete principal)	m/min	≤110	2ª camada do tambor
	Tempo de derivação da lança	s	60	
	Lança telescópica fora de tempo	s	750	
Condução	Velocidade máxima de condução	km/h	≥80	
	Capacidade máxima de nivelamento	%	40	
	Diâmetro mínimo de giro	m	24	
	Distância mínima ao solo	mm	310	
	Limites para poluentes de exaustão e fumaça		Cumprir com as normas relacionadas	GB3847-2018, GB17691-2005 (Estágio Nacional Chinês III)
	Consumo de combustível por cem quilômetros	L	46	

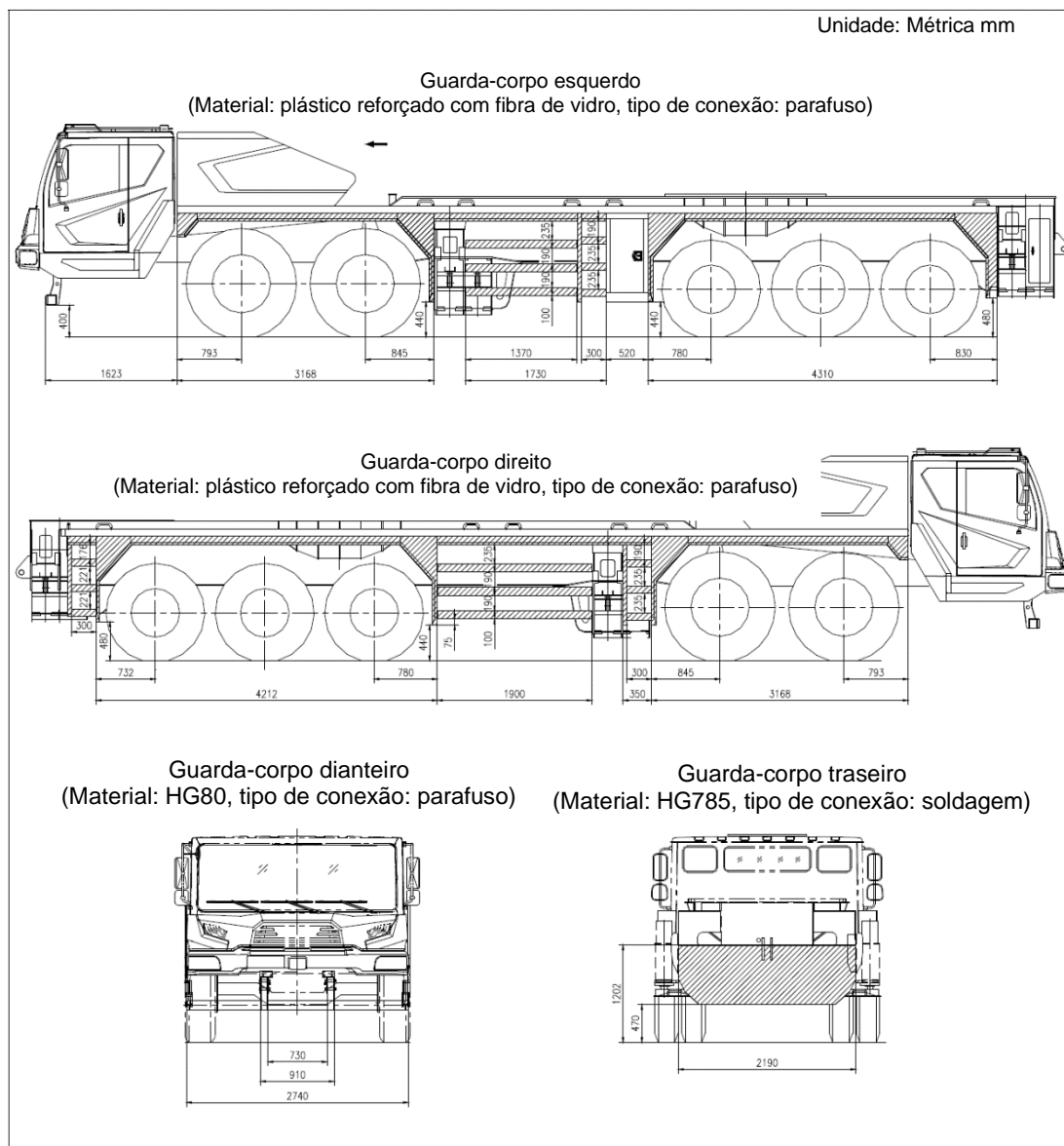
Tabela 1-1 (continuação)

Item		Valor	Observações		
Massa	Ângulo de balanço dianteiro/traseiro	°	10/19	13/19 (proteção frontal dobrada)	
	Distância do freio	m	≤10	Velocidade inicial: 30km/h	
	Peso morto em condição de condução	kg	54000		
	Massa em ordem de marcha do veículo completo	kg	53805		
	Carga do eixo 1 e 2	kg	23000		
	Carga do eixo 3 e 4	kg	21000		
	Carga do eixo 5	kg	10000		
Dimensões	Dimensões gerais (C x L x A)	mm	15700x3000x3920		
	Espalhamento do estabilizador (C)	m	6,94		
	Espalhamento do estabilizador (L)	m	Totalmente estendido: 8,0, Intermediariamente estendido: 5,27		
	Comprimento da lança principal	m	13,2-70,0		
	Ângulo da lança	°	-1 - 80		
	Comprimento do braço	m	10,4, 17,5		
	Deslocamento	°	0, 15, 30		
	Balanço dianteiro/traseiro	mm	2785 / 1725		
	Número de eixos		5		
	Distância entre eixos	mm	1530+4270+1350+1350		
	Estrias	Dianteiro	mm	2400/2400	
		Traseiro	mm	2063/2063/2200 (2320)	2200 para pneus 325/95R2, 2320 para pneus 415/80R22
	Raio de giro da cauda	mm	4760		

Tabela 1-1 (continuação)

Item		Valor	Observações
Alinhamento de roda	Ângulo de inclinação do pino mestre	°	5
	Ângulo do caster da roda	°	2
	Ângulo de curvatura da roda	°	1
Motor	Modelo		WP12.375E50
	Tipo		6 cilindros em linha, turboalimentado, intercooler
	Tipo de combustível		Diesel leve
	Deslocamento	ml	11596
	Potência nominal / RPM	kW/r/min	276 / 1900
	Torque máx. / RPM	N.m/r/min	1800/1000 - 1400
Transmissão Manual	Modelo		10JSD180A
	Tipo		Mudança de velocidade escalonada mecânica
	Método de operação		Operação manual mecânica
	Número de velocidades		10 velocidades à frente e 2 velocidades à ré
	Relação de velocidade		Velocidades de avanço: 11,03 / 8,12 / 5,98 / 4,46 / 3,30 / 2,47 / 1,83 / 1,34 / 1,00 / 0,74 Velocidades de ré: 10,55 / 2,37
Transmissão automática	Modelo		10JZSD200A
	Tipo		Mudança de velocidade escalonada mecânica
	Método de operação		Operação mecânica manual e automática integrada
	Número de velocidades		10 velocidades à frente e 1 velocidade à ré
	Relação de velocidade		Velocidades de avanço: 11,06 / 8,18 / 6,00 / 4,48 / 3,33 / 2,47 / 1,83 / 1,34 / 1,00 / 0,74 Velocidade de ré: 10,55

Sistema de direção	Tipo de direção			Volante	
	Diâmetro externo do volante		mm	480	
	Coluna de direção			Acoplamento universal	
	Engrenagem de direção	Modelo		SF120-04a-Z/Y	
		Tipo		Engrenagem de direção hidráulica de circulação integral	
	Bomba de direção	Modelo		QC40/15-WP12N1	
Tipo			Bomba de engrenagem		
Eixo de acionamento	Tipo de acionamento			10x4	
	Relação de velocidade			6,723	
Número de molas de lâmina (dianteira/traseira)				12/12/10/-	Uma suspensão a ar é instalada para o eixo 5
Capacidade da cabine				3	
Capacidade do tanque de combustível			L	400	
Capacidade do tanque de óleo hidráulico			L	740	

1.3.4 Parâmetros de trabalho

1.3.4.1 Força máxima de suporte por estabilizador

Quando o guindaste está trabalhando dentro das capacidades de elevação nominais, a força máxima de suporte por estabilizador é de 85 toneladas.

1.3.4.2 Gancho

Tabela 1-2 Configurações de gancho

Modelo	Número de polias	Passagem máxima	Peso	Observações
90 t	6	13	830 kg	Gancho de âncora (opcional)
60 t	6	12	662 kg	Gancho de âncora (opcional)
60 t	6	12	670 kg	Haste reta com gancho único (configuração padrão)
6,5 t	-	1	200 kg	Configuração padrão

1.3.4.3 Especificação do cabo

Tabela 1-3 Seleção de combustível

Tipo de corda	Código padrão	Especificação	Comprimento
Corda de içamento principal	YB/T5359-2010	GT15Z(15×K7)-20mm-1960-esquerdo	320000 mm
Corda de içamento principal	YB/T5359-2010	GT15Z(15×K7)-20mm-1960-esquerdo	240000 mm

1.3.4.4 Passagem de corda padrão

Tabela 1-4 Passagens de corda padrão para vários

Comprimento de lança (m)	13,2-21,6	21,6-25,8	25,8-30,0	30,0-34,2	34,2-38,4
Passagem	12	11	9	8	7
Comprimento de lança (m)	38,4-42,6	42,6-46,8	46,8-51,0	51,0-70,0	63,6+9,5
Passagem	6	5	4	3	1
Comprimento de lança (m)	63,6+17,5	63,6+17,5	70+9,5	70+10,4	70+17,5
Passagem	1	1	1	1	1
Comprimento de lança (m)	63,6+9,5+17,5	63,6 +9,5 +7 +17,5			
Passagem	1	1			

**CUIDADO**

- (1) **Se as passagens do cabo forem menores que o valor listado na tabela acima durante a elevação, examine a carga no cabo de aço simples para certificar-se de que não é maior do que a capacidade máx. de elevação permitida de um único cabo de aço.**
- (2) **A capacidade máxima de elevação permitida de um único cabo de aço é de 6500 kg.**

1.3.5 Tabelas de capacidade de elevação

Este guindaste é fornecido com várias mesas de capacidade de elevação. O operador deve selecionar a carga de elevação nominal adequada consultando as respectivas tabelas de capacidade de elevação de acordo com as condições reais de trabalho. Para os detalhes, consulte as tabelas abaixo.

- a) Ao levantar capacidade nominal $\leq 60t$, deve-se usar um gancho de 60t;
- b) Quando $60t < \text{capacidade de elevação nominal} \leq 70t$, um gancho de 70t deve ser usado;
- c) Quando $70t < \text{capacidade de elevação nominal} \leq 80t$, um gancho de 80t deve ser usado. Quando o fator de passagem for 13, um dispositivo adicional deve ser usado.
- d) Ao levantar capacidade $> 80t$, deve-se usar um gancho de 90t. Quando o fator de passagem for 13, um dispositivo adicional deve ser usado.

Tabela 1-5 Tabela de capacidade de elevação (apenas com lança principal)

Unidade: tonelada

Estabilizadores totalmente estendidos para 8m, contrapeso de 34t, sobre a área de trabalho lateral ou traseira															
RAIO DE TRABALHO (m)	Comprimento de lança (m)												RAIO DE TRABALHO (m)		
	13,2 ★	17,4	17,4	17,4	17,4	17,4	21,6	21,6	21,6	21,6	21,6	21,6		21,6 ★	
3,0	100,0	40,5	66,0	72,0	72,0	72,0	29,5	44,0	65,0	68,0	68,0	68,0	3,0		
3,5	86,0	38,0	61,0	72,0	72,0	72,0	28,0	42,0	60,0	66,0	67,0	67,0	3,5		
4,0	80,0	36,0	56,5	71,0	71,0	71,0	26,0	40,0	55,0	65,0	66,0	66,0	4,0		
4,5	75,0	34,5	52,5	70,0	70,0	70,0	24,0	38,0	52,0	63,5	65,0	65,0	4,5		
5,0	70,0	33,0	49,0	65,0	66,0	66,0	23,0	36,0	49,0	60,0	63,0	63,0	5,0		
5,5	67,0	31,5	46,0	61,0	62,0	62,0	22,0	34,0	46,0	56,0	60,0	60,0	5,5		
6,0	61,0	30,0	43,0	57,5	59,0	59,0	21,0	31,5	43,0	53,0	57,0	57,0	6,0		
7,0	52,0	27,5	38,5	51,5	52,0	52,0	19,0	29,0	39,0	47,0	50,0	50,0	7,0		
8,0	45,0	25,5	35,0	45,5	45,5	45,0	17,0	26,5	36,0	44,0	44,5	44,5	8,0		
9,0	37,0	24,0	32,0	40,0	40,0	39,5	16,0	24,5	33,0	39,0	39,0	39,0	9,0		
10,0		22,5	29,5	36,0	36,0	35,5	15,0	22,5	30,0	36,0	35,5	35,0	10,0		
11,0		21,5	27,0	32,5	32,5	32,0	13,9	21,0	28,0	32,5	32,0	31,5	11,0		
12,0		20,3	25,5	29,5	29,5	29,0	13,0	19,5	26,0	31,0	30,0	29,0	12,0		
14,0							11,5	17,0	23,0	26,5	25,5	24,5	14,0		
16,0							10,4	15,0	20,5	21,0	20,5	19,5	16,0		
18,0													18,0		
20,0													20,0		
22,0													22,0		
24,0													24,0		
26,0													26,0		
28,0													28,0		
30,0													30,0		
32,0													32,0		
34,0													34,0		
36,0													36,0		
38,0													38,0		
40,0													40,0		
42,0													42,0		
44,0													44,0		
46,0													46,0		
48,0													48,0		
50,0													50,0		
Passagem Gancho	12	12					12					Passagem Gancho			
		60t													
Modo telescópico	I	1	1	1	1	1	1	1	1	1	1	1	2	I	Modo telescópico
	II	1	1	1	1	1	2	1	1	1	1	2	2	II	
	III	1	1	1	1	2	1	1	1	1	2	2	1	III	
	IV	1	1	1	2	1	1	1	1	2	2	1	1	IV	
	V	1	1	2	1	1	1	1	2	2	1	1	1	V	
	VI	1	2	1	1	1	1	3	2	1	1	1	1	VI	

Tabela 1-6 Tabela de capacidade de elevação (apenas com lança principal)

Unidade: tonelada

Estabilizadores totalmente estendidos para 8m, contrapeso de 34t, sobre a área de trabalho lateral ou traseira															
RAIO DE TRABALHO (m)	Comprimento de lança (m)												RAIO DE TRABALHO (m)		
	25,8	25,8	25,8	25,8	25,8	25,8 ★	30,0	30,0	30,0	30,0	30,0	30,0		30,0 ★	
3,0														3,0	
3,5														3,5	
4,0	25,0	25,0	43,0	60,0	60,0	60,0								4,0	
4,5	23,5	23,5	41,0	56,0	60,0	60,0								4,5	
5,0	22,0	22,0	39,5	53,0	60,0	60,0	19,0	24,0	26,0	42,0	53,0	53,0		5,0	
5,5	21,0	21,0	38,0	50,0	58,0	58,0	18,5	23,0	24,5	40,5	51,5	51,5		5,5	
6,0	20,0	20,0	36,0	47,0	54,0	54,0	17,5	22,0	23,0	39,5	50,0	50,0		6,0	
7,0	18,0	18,0	33,0	42,0	49,0	49,0	15,8	20,0	21,0	36,0	48,0	48,0		7,0	
8,0	16,5	16,5	30,0	38,0	45,0	45,0	14,3	18,5	19,0	33,5	44,0	44,0		8,0	
9,0	15,0	15,0	28,0	35,0	39,5	39,5	13,0	17,0	17,5	31,0	40,0	40,0		9,0	
10,0	14,0	14,0	26,0	32,0	35,0	35,0	12,0	15,5	16,0	28,5	35,5	35,5		10,0	
11,0	13,0	13,0	24,5	30,0	32,5	32,0	11,0	14,5	15,0	27,0	31,5	31,5		11,0	
12,0	12,0	12,0	22,5	28,0	30,0	29,0	10,3	13,5	14,0	25,0	29,5	29,0		12,0	
14,0	10,5	10,5	20,0	24,0	26,0	25,0	9,0	11,9	12,2	22,0	25,5	25,0		14,0	
16,0	9,4	9,3	18,0	21,5	21,5	20,5	8,0	10,7	10,7	19,5	22,5	21,2		16,0	
18,0	8,5	8,4	16,2	18,5	17,5	16,5	7,1	9,6	9,6	17,5	18,5	17,3		18,0	
20,0	7,7	7,6	14,7	15,5	14,5	13,5	6,4	8,7	8,7	16,0	15,5	14,3		20,0	
22,0								5,8	8,0	7,9	14,3	13,2	12,0	22,0	
24,0								5,3	7,3	7,2	12,3	11,4	10,2	24,0	
26,0														26,0	
28,0														28,0	
30,0														30,0	
32,0														32,0	
34,0														34,0	
36,0														36,0	
38,0														38,0	
40,0														40,0	
42,0														42,0	
44,0														44,0	
46,0														46,0	
48,0														48,0	
50,0														50,0	
Passagem	11						9						Passagem		
Gancho	60t												Gancho		
Modo telescópico	I	1	1	1	1	1	2	1	1	1	1	1	2	I	Modo telescópico
	II	1	1	1	1	2	2	1	1	1	1	2	2	II	
	III	1	1	1	2	2	2	1	1	1	2	2	2	III	
	IV	1	1	2	2	2	1	1	2	3	2	2	2	IV	
	V	2	3	2	2	1	1	3	3	2	2	2	1	V	
	VI	3	2	2	1	1	1	3	2	2	2	1	1	VI	

Tabela 1-7 Tabela de capacidade de elevação (apenas com lança principal)

Unidade: tonelada

Estabilizadores totalmente estendidos para 8m, contrapeso de 34t, sobre a área de trabalho lateral ou traseira															
RAIO DE TRABALHO (m)	Comprimento de lança (m)												RAIO DE TRABALHO (m)		
	34,2	34,2	34,2	34,2	34,2	34,2 ★	38,4	38,4	38,4	38,4	38,4	38,4		38,4 ★	
3,0														3,0	
3,5														3,5	
4,0														4,0	
4,5														4,5	
5,0														5,0	
5,5														5,5	
6,0	19,0	21,5	25,5	26,0	43,0	46,0								6,0	
7,0	17,0	19,0	23,0	23,5	40,5	44,0	17,0	20,0	21,5	26,0	30,5	41,5		7,0	
8,0	15,5	17,5	21,0	21,5	38,0	42,0	15,5	18,5	19,5	24,0	28,0	39,0		8,0	
9,0	14,5	16,0	19,5	19,5	35,0	39,0	14,0	17,0	18,0	22,0	25,5	36,0		9,0	
10,0	13,3	14,5	18,0	18,0	32,5	36,0	13,0	15,7	16,5	20,3	23,5	33,5		10,0	
11,0	12,3	13,5	16,5	16,5	30,5	33,0	12,0	14,5	15,2	18,8	22,0	31,5		11,0	
12,0	11,5	12,5	15,5	15,5	28,5	30,0	11,0	13,5	14,0	17,5	20,5	30,0		12,0	
14,0	10,1	10,8	13,5	13,5	25,0	26,0	9,5	11,7	12,2	15,4	17,7	26,0		14,0	
16,0	8,9	9,6	11,8	11,8	22,5	22,0	8,5	10,4	10,8	13,6	15,7	22,7		16,0	
18,0	8,0	8,5	10,5	10,5	19,5	18,1	7,5	9,3	9,6	12,1	14,0	18,8		18,0	
20,0	7,2	7,7	9,5	9,4	16,5	15,1	6,7	8,4	8,6	11,0	12,5	15,8		20,0	
22,0	6,5	6,9	8,6	8,5	14,1	12,7	6,0	7,6	7,7	10,0	11,3	13,5		22,0	
24,0	6,0	6,3	7,9	7,8	12,2	10,9	5,5	6,9	7,0	9,0	10,3	11,6		24,0	
26,0	5,5	5,7	7,2	7,1	10,6	9,3	5,0	6,3	6,3	8,3	9,4	10,0		26,0	
28,0	5,1	5,3	6,6	6,5	9,3	8,0	4,5	5,8	5,8	7,6	8,6	8,7		28,0	
30,0							4,2	5,3	5,3	7,0	7,9	7,6		30,0	
32,0							3,9	4,8	4,8	6,5	7,0	6,6		32,0	
34,0														34,0	
36,0														36,0	
38,0														38,0	
40,0														40,0	
42,0														42,0	
44,0														44,0	
46,0														46,0	
48,0														48,0	
50,0														50,0	
Passagem	8						7						Passagem		
Gancho	60t												Gancho		
Modo telescópico	I	1	1	1	1	1	2	1	1	1	1	1	2	I	Modo telescópico
	II	1	1	1	1	2	2	1	1	1	2	3	2	II	
	III	1	1	2	3	2	2	1	2	3	3	2	2	III	
	IV	2	3	3	2	2	2	3	3	3	2	2	2	IV	
	V	3	3	2	2	2	2	3	3	2	2	2	2	V	
	VI	3	2	2	2	2	1	3	2	2	2	2	2	VI	

Tabela 1-8 Tabela de capacidade de elevação (apenas com lança principal)

Unidade: tonelada

Estabilizadores totalmente estendidos para 8m, contrapeso de 34t, sobre a área de trabalho lateral ou traseira															
RAIO DE TRABALHO (m)	Comprimento de lança (m)												RAIO DE TRABALHO (m)		
	42,6	42,6	42,6	42,6	42,6	42,6★		46,8	46,8	46,8	46,8	46,8★			
3,0														3,0	
3,5														3,5	
4,0														4,0	
4,5														4,5	
5,0														5,0	
5,5														5,5	
6,0														6,0	
7,0														7,0	
8,0	16,5	18,0	21,5	26,0	30,0	32,5								8,0	
9,0	15,0	16,5	20,0	24,0	28,0	30,0								9,0	
10,0	14,0	15,0	18,5	22,0	26,0	28,0		14,0	16,5	19,5	23,0	25,0		10,0	
11,0	12,9	14,0	17,0	20,3	24,0	26,0		12,8	15,3	18,0	21,3	23,5		11,0	
12,0	12,0	12,9	15,8	18,8	22,3	24,0		11,9	14,2	16,8	19,8	22,0		12,0	
14,0	10,4	11,0	13,8	16,3	19,5	21,0		10,3	12,3	14,6	17,4	19,0		14,0	
16,0	9,2	9,8	12,2	14,4	17,3	18,5		9,0	10,9	13,0	15,4	16,7		16,0	
18,0	8,2	8,6	10,8	12,7	15,4	16,5		8,0	9,6	11,5	13,6	14,8		18,0	
20,0	7,3	7,7	9,7	11,3	13,8	14,7		7,1	8,6	10,2	12,2	13,2		20,0	
22,0	6,6	6,9	8,7	10,2	12,5	13,0		6,4	7,7	9,2	11,0	11,8		22,0	
24,0	6,0	6,2	7,9	9,2	11,4	11,0		5,7	7,0	8,3	10,0	10,6		24,0	
26,0	5,5	5,6	7,2	8,2	9,9	9,5		5,2	6,4	7,5	9,0	9,5		26,0	
28,0	5,0	5,1	6,6	7,6	8,6	8,2		4,7	5,8	6,8	8,3	8,2		28,0	
30,0	4,6	4,7	6,0	7,0	7,5	7,1		4,3	5,3	6,2	7,6	7,1		30,0	
32,0	4,3	4,3	5,6	6,4	6,5	6,2		4,0	4,9	5,7	6,7	6,1		32,0	
34,0	4,0	3,9	5,1	5,9	5,7	5,3		3,6	4,5	5,2	5,8	5,3		34,0	
36,0	3,7	3,6	4,7	5,4	5,0	4,6		3,3	4,1	4,8	5,1	4,6		36,0	
38,0								3,0	3,8	4,4	4,4	3,9		38,0	
40,0								2,8	3,5	4,1	3,9	3,3		40,0	
42,0														42,0	
44,0														44,0	
46,0														46,0	
48,0														48,0	
50,0														50,0	
Passagem Gancho	6						5						Passagem Gancho		
	60t														
Modo telescópico	I	1	1	1	1	2	3		1	1	1	2	3	I	Telescópico modo
	II	1	1	2	3	3	2		1	2	3	3	3	II	
	III	2	3	3	3	2	2		3	3	3	3	2	III	
	IV	3	3	3	2	2	2		3	3	3	2	2	IV	
	V	3	3	2	2	2	2		3	3	2	2	2	V	
	VI	3	2	2	2	2	2		3	2	2	2	2	VI	

Tabela 1-9 Tabela de capacidade de elevação (apenas com lança principal)

Unidade: tonelada

Estabilizadores totalmente estendidos para 8m, contrapeso de 34t, sobre a área de trabalho lateral ou traseira														
RAIO DE TRABALHO (m)	Comprimento de lança (m)												RAIO DE TRABALHO (m)	
	51,0	51,0	51,0	51,0 ★	55,2	55,2	55,2 ★		59,4	59,4 ★	63,6 ★	70,0 ★		
5,0														5,0
5,5														5,5
6,0														6,0
7,0														7,0
8,0														8,0
9,0														9,0
10,0														10,0
11,0	13,5	15,5	18,0	20,0										11,0
12,0	13,0	14,5	17,0	19,5	13,0	14,0	15,5							12,0
14,0	11,3	13,0	15,5	17,5	11,5	13,0	14,5		11,0	12,0				14,0
16,0	10,0	11,5	13,8	15,4	10,5	12,0	13,5		10,5	11,5	9,5			16,0
18,0	9,0	10,4	12,4	13,6	9,5	11,0	12,5		9,6	11,0	9,2	7,0		18,0
20,0	8,0	9,3	11,0	12,2	8,5	9,8	11,2		9,0	10,2	9,0	7,0		20,0
22,0	7,2	8,4	10,0	11,0	7,8	9,0	10,2		8,2	9,3	8,4	6,8		22,0
24,0	6,5	7,6	9,0	9,8	7,0	8,2	9,3		7,5	8,5	7,8	6,5		24,0
26,0	6,0	6,9	8,1	8,9	6,4	7,6	8,4		6,9	7,8	7,2	6,2		26,0
28,0	5,5	6,3	7,4	8,0	5,9	6,9	7,6		6,4	7,1	6,6	5,9		28,0
30,0	5,0	5,7	6,8	7,3	5,4	6,3	6,8		5,9	6,6	6,1	5,6		30,0
32,0	4,5	5,2	6,2	6,3	5,0	5,8	6,2		5,5	6,1	5,6	5,2		32,0
34,0	4,2	4,8	5,7	5,5	4,6	5,3	5,6		5,1	5,5	5,2	4,8		34,0
36,0	3,9	4,4	5,2	4,7	4,2	4,9	5,0		4,7	5,1	4,8	4,4		36,0
38,0	3,6	4,0	4,7	4,1	3,9	4,5	4,4		4,4	4,6	4,4	4,1		38,0
40,0	3,3	3,7	4,1	3,5	3,6	4,2	3,8		3,9	4,1	4,0	3,8		40,0
42,0	3,1	3,4	3,6	3,0	3,3	3,9	3,2		3,7	3,5	3,7	3,5		42,0
44,0	2,9	3,2	3,1	2,5	3,1	3,4	2,8		3,5	3,1	3,4	3,2		44,0
46,0					2,8	3,0	2,3		3,2	2,7	3,0	2,9		46,0
48,0					2,6	2,6	2,0		2,8	2,3	2,7	2,6		48,0
50,0									2,5	2,0	2,3	2,3		50,0
52,0									2,2	1,7	2,0	2,0		52,0
54,0											1,7	1,7		54,0
56,0											1,4	1,5		56,0
58,0												1,2		58,0
60,0												1,0		60,0
Passagem	4			3			3			3			Passagem	
Gancho	60t												Gancho	
Modo telescópico modo	I	1	1	2	3	1	2	3		2	3	3	4	I
	II	2	3	3	3	3	3	3		3	3	3	4	II
	III	3	3	3	3	3	3	3		3	3	3	4	III
	IV	3	3	3	2	3	3	3		3	3	3	4	IV
	V	3	3	2	2	3	3	2		3	3	3	4	V
	VI	3	2	2	2	3	2	2		3	2	3	4	VI
Modo telescópico														

Tabela 1-10 Tabela de capacidade de elevação (apenas com lança principal)

Unidade: tonelada

Estabilizadores totalmente estendidos para 8m, contrapeso de 23t, sobre a área de trabalho lateral ou traseira														
RAIO DE TRABALHO (m)	Comprimento de lança (m)												RAIO DE TRABALHO (m)	
	13,2★	17,4	17,4	17,4	17,4	17,4	17,4	21,6	21,6	21,6	21,6	21,6		21,6★
3,0	100,0	40,5	66,0	72,0	72,0	72,0	29,5	44,0	65,0	68,0	68,0	68,0	68,0	3,0
3,5	86,0	38,0	61,0	72,0	72,0	72,0	28,0	42,0	60,0	66,0	67,0	67,0	67,0	3,5
4,0	80,0	36,0	56,5	71,0	71,0	71,0	26,0	40,0	55,0	65,0	66,0	66,0	66,0	4,0
4,5	75,0	34,5	52,5	70,0	70,0	70,0	24,0	38,0	52,0	63,5	65,0	65,0	65,0	4,5
5,0	68,0	33,0	49,0	65,0	66,0	66,0	23,0	36,0	49,0	60,0	63,0	63,0	63,0	5,0
5,5	64,0	31,5	46,0	61,0	62,0	62,0	22,0	34,0	46,0	56,0	60,0	60,0	60,0	5,5
6,0	58,0	30,0	43,0	57,5	59,0	59,0	21,0	31,5	43,0	53,0	57,0	57,0	57,0	6,0
7,0	50,0	27,5	38,5	49,0	50,0	50,0	19,0	29,0	39,0	45,0	48,0	48,0	48,0	7,0
8,0	43,5	25,5	35,0	42,0	42,5	42,0	17,0	26,5	36,0	40,0	41,0	41,0	41,0	8,0
9,0	36,0	24,0	32,0	38,0	38,5	38,0	16,0	24,5	33,0	36,0	37,0	37,0	37,0	9,0
10,0		22,5	29,5	35,0	34,5	34,0	15,0	22,5	30,0	33,0	33,5	33,0	33,0	10,0
11,0		21,5	27,0	30,5	30,0	29,5	13,9	21,0	28,0	29,5	29,5	29,0	29,0	11,0
12,0		20,3	25,5	26,0	25,5	25,0	13,0	19,5	26,0	26,0	25,0	24,5	24,5	12,0
14,0							11,5	17,0	22,0	20,5	19,5	19,0	19,0	14,0
16,0							10,4	15,0	17,0	16,0	15,0	14,5	14,5	16,0
18,0														18,0
20,0														20,0
22,0														22,0
24,0														24,0
26,0														26,0
28,0														28,0
30,0														30,0
32,0														32,0
34,0														34,0
36,0														36,0
38,0														38,0
40,0														40,0
42,0														42,0
44,0														44,0
46,0														46,0
48,0														48,0
50,0														50,0
Passagem	12	12						12						Passagem
Gancho	60t													Gancho
Modo telescópico	I	1	1	1	1	1	1	1	1	1	1	1	2	I
	II	1	1	1	1	1	2	1	1	1	1	2	2	II
	III	1	1	1	1	2	1	1	1	1	2	2	1	III
	IV	1	1	1	2	1	1	1	1	2	2	1	1	IV
	V	1	1	2	1	1	1	1	2	2	1	1	1	V
	VI	1	2	1	1	1	1	3	2	1	1	1	1	VI
														Modo telescópico

Tabela 1-11 Tabela de capacidade de elevação (apenas com lança principal)

Unidade: tonelada

Estabilizadores totalmente estendidos para 8m, contrapeso de 23t, sobre a área de trabalho lateral ou traseira															
RAIO DE TRABALHO (m)	Comprimento de lança (m)												RAIO DE TRABALHO (m)		
	25,8	25,8	25,8	25,8	25,8	25,8★	30,0	30,0	30,0	30,0	30,0	30,0		30,0★	
3,0														3,0	
3,5														3,5	
4,0	25,0	25,0	43,0	60,0	60,0	60,0								4,0	
4,5	23,5	23,5	41,0	56,0	60,0	60,0								4,5	
5,0	22,0	22,0	39,5	53,0	60,0	60,0	19,0	24,0	26,0	42,0	53,0	53,0		5,0	
5,5	21,0	21,0	38,0	50,0	58,0	58,0	18,5	23,0	24,5	40,5	51,5	51,5		5,5	
6,0	20,0	20,0	36,0	47,0	54,0	54,0	17,5	22,0	23,0	39,5	50,0	50,0		6,0	
7,0	18,0	18,0	33,0	42,0	46,0	46,0	15,8	20,0	21,0	36,0	48,0	48,0		7,0	
8,0	16,5	16,5	30,0	38,0	41,0	41,0	14,3	18,5	19,0	33,5	44,0	44,0		8,0	
9,0	15,0	15,0	28,0	35,0	37,0	37,0	13,0	17,0	17,5	31,0	40,0	38,0		9,0	
10,0	14,0	14,0	26,0	32,0	33,0	33,0	12,0	15,5	16,0	28,5	35,5	33,0		10,0	
11,0	13,0	13,0	24,5	30,0	29,0	29,0	11,0	14,5	15,0	27,0	30,0	29,0		11,0	
12,0	12,0	12,0	22,5	28,0	27,0	26,0	10,3	13,5	14,0	25,0	27,0	26,0		12,0	
14,0	10,5	10,5	20,0	21,0	20,5	19,5	9,0	11,9	12,2	22,0	21,5	20,5		14,0	
16,0	9,4	9,3	18,0	17,0	16,5	15,5	8,0	10,7	10,7	18,5	17,0	16,0		16,0	
18,0	8,5	8,4	15,5	13,5	13,0	12,0	7,1	9,6	9,6	15,2	14,0	13,0		18,0	
20,0	7,7	7,6	13,0	11,5	11,0	10,0	6,4	8,7	8,7	12,8	11,6	10,6		20,0	
22,0							5,8	8,0	7,9	11,0	9,8	8,8		22,0	
24,0							5,3	7,3	7,2	9,4	8,2	7,2		24,0	
26,0														26,0	
28,0														28,0	
30,0														30,0	
32,0														32,0	
34,0														34,0	
36,0														36,0	
38,0														38,0	
40,0														40,0	
42,0														42,0	
44,0														44,0	
46,0														46,0	
48,0														48,0	
50,0														50,0	
Passagem	11						9						Passagem		
Gancho	60t												Gancho		
Modo telescópico	I	1	1	1	1	1	2	1	1	1	1	1	2	I	Modo telescópico
	II	1	1	1	1	2	2	1	1	1	1	2	2	II	
	III	1	1	1	2	2	2	1	1	1	2	2	2	III	
	IV	1	1	2	2	2	1	1	2	3	2	2	2	IV	
	V	2	3	2	2	1	1	3	3	2	2	2	1	V	
	VI	3	2	2	1	1	1	3	2	2	2	1	1	VI	

Tabela 1-12 Tabela de capacidade de elevação (apenas com lança principal)

Unidade: tonelada

Estabilizadores totalmente estendidos para 8m, contrapeso de 23t, sobre a área de trabalho lateral ou traseira														
RAIO DE TRABALHO (m)	Comprimento de lança (m)												RAIO DE TRABALHO (m)	
	34,2	34,2	34,2	34,2	34,2	34,2★	38,4	38,4	38,4	38,4	38,4	38,4		38,4★
3,0														3,0
3,5														3,5
4,0														4,0
4,5														4,5
5,0														5,0
5,5														5,5
6,0	19,0	21,5	25,5	26,0	43,0	46,0								6,0
7,0	17,0	19,0	23,0	23,5	40,5	44,0	17,0	20,0	21,5	26,0	30,5	41,5		7,0
8,0	15,5	17,5	21,0	21,5	38,0	42,0	15,5	18,5	19,5	24,0	28,0	39,0		8,0
9,0	14,5	16,0	19,5	19,5	35,0	39,0	14,0	17,0	18,0	22,0	25,5	36,0		9,0
10,0	13,3	14,5	18,0	18,0	32,5	34,0	13,0	15,7	16,5	20,3	23,5	33,5		10,0
11,0	12,3	13,5	16,5	16,5	30,5	31,5	12,0	14,5	15,2	18,8	22,0	31,5		11,0
12,0	11,5	12,5	15,5	15,5	28,5	28,0	11,0	13,5	14,0	17,5	20,5	28,5		12,0
14,0	10,1	10,8	13,5	13,5	22,5	21,5	9,5	11,7	12,2	15,4	17,7	22,0		14,0
16,0	8,9	9,6	11,8	11,8	18,0	17,0	8,5	10,4	10,8	13,6	15,7	17,5		16,0
18,0	8,0	8,5	10,5	10,5	15,0	14,0	7,5	9,3	9,6	12,1	14,0	14,5		18,0
20,0	7,2	7,7	9,5	9,4	12,7	11,5	6,7	8,4	8,6	11,0	12,5	12,0		20,0
22,0	6,5	6,9	8,6	8,5	10,7	9,5	6,0	7,6	7,7	10,0	10,5	10,0		22,0
24,0	6,0	6,3	7,9	7,8	9,2	8,0	5,5	6,9	7,0	9,0	9,0	8,5		24,0
26,0	5,5	5,7	7,2	7,1	8,0	6,7	5,0	6,3	6,3	8,0	7,7	7,2		26,0
28,0	5,1	5,3	6,6	6,5	6,9	5,6	4,5	5,8	5,8	7,0	6,7	6,2		28,0
30,0							4,2	5,3	5,3	6,0	5,7	5,2		30,0
32,0							3,9	4,8	4,8	5,2	5,0	4,5		32,0
34,0														34,0
36,0														36,0
38,0														38,0
40,0														40,0
42,0														42,0
44,0														44,0
46,0														46,0
48,0														48,0
50,0														50,0
Passagem	8						7						Passagem	
Gancho	60t												Gancho	
Modo telescópico	I	1	1	1	1	1	2	1	1	1	1	1	2	I
	II	1	1	1	1	2	2	1	1	1	2	3	2	II
	III	1	1	2	3	2	2	1	2	3	3	2	2	III
	IV	2	3	3	2	2	2	3	3	3	2	2	2	IV
	V	3	3	2	2	2	2	3	3	2	2	2	2	V
	VI	3	2	2	2	2	1	3	2	2	2	2	2	VI
														Modo telescópico

Tabela 1-13 Tabela de capacidade de elevação (apenas com lança principal)

Unidade: tonelada

Estabilizadores totalmente estendidos para 8m, contrapeso de 23t, sobre a área de trabalho lateral ou traseira															
RAIO DE TRABALHO (m)	Comprimento de lança (m)												RAIO DE TRABALHO (m)		
	42,6	42,6	42,6	42,6	42,6	42,6★		46,8	46,8	46,8	46,8	46,8★			
3,0														3,0	
3,5														3,5	
4,0														4,0	
4,5														4,5	
5,0														5,0	
5,5														5,5	
6,0														6,0	
7,0														7,0	
8,0	16,5	18,0	21,5	26,0	30,0	32,5								8,0	
9,0	15,0	16,5	20,0	24,0	28,0	30,0								9,0	
10,0	14,0	15,0	18,5	22,0	26,0	28,0		14,0	16,5	19,5	23,0	25,0		10,0	
11,0	12,9	14,0	17,0	20,3	24,0	26,0		12,8	15,3	18,0	21,3	23,5		11,0	
12,0	12,0	12,9	15,8	18,8	22,3	24,0		11,9	14,2	16,8	19,8	22,0		12,0	
14,0	10,4	11,0	13,8	16,3	19,5	21,0		10,3	12,3	14,6	17,4	19,0		14,0	
16,0	9,2	9,8	12,2	14,4	17,3	17,5		9,0	10,9	13,0	15,4	16,7		16,0	
18,0	8,2	8,6	10,8	12,7	14,5	14,0		8,0	9,6	11,5	13,6	13,5		18,0	
20,0	7,3	7,7	9,7	11,3	12,0	11,7		7,1	8,6	10,2	12,2	11,0		20,0	
22,0	6,6	6,9	8,7	10,2	10,2	9,7		6,4	7,7	9,2	9,8	9,6		22,0	
24,0	6,0	6,2	7,9	9,0	8,6	8,1		5,7	7,0	8,3	8,5	8,1		24,0	
26,0	5,5	5,6	7,2	7,7	7,3	6,9		5,2	6,4	7,5	7,4	6,9		26,0	
28,0	5,0	5,1	6,6	6,8	6,2	5,8		4,7	5,8	6,8	6,3	5,8		28,0	
30,0	4,6	4,7	6,0	5,9	5,3	4,9		4,3	5,3	6,0	5,4	4,9		30,0	
32,0	4,3	4,3	5,2	5,0	4,4	4,0		4,0	4,9	5,2	4,5	4,0		32,0	
34,0	4,0	3,9	4,6	4,4	3,8	3,4		3,6	4,5	4,5	3,8	3,3		34,0	
36,0	3,7	3,6	4,0	3,8	3,2	2,8		3,3	4,1	4,0	3,3	2,7		36,0	
38,0								3,0	3,8	3,5	2,8	2,2		38,0	
40,0								2,8	3,3	3,0	2,3	1,7		40,0	
42,0														42,0	
44,0														44,0	
46,0														46,0	
48,0														48,0	
50,0														50,0	
Passagem	6							5						Passagem	
Gancho	60t												Gancho		
Modo telescópico	I	1	1	1	1	2	3		1	1	1	2	3	I	Modo telescópico
	II	1	1	2	3	3	2		1	2	3	3	3	II	
	III	2	3	3	3	2	2		3	3	3	3	2	III	
	IV	3	3	3	2	2	2		3	3	3	2	2	IV	
	V	3	3	2	2	2	2		3	3	2	2	2	V	
	VI	3	2	2	2	2	2		3	2	2	2	2	VI	

Tabela 1-14 Tabela de capacidade de elevação (apenas com lança principal)
Unidade: tonelada

Estabilizadores totalmente estendidos para 8m, contrapeso de 23t, sobre a área de trabalho lateral ou traseira														
RAIO DE TRABALHO (m)	Comprimento de lança (m)												RAIO DE TRABALHO (m)	
	51,0	51,0	51,0	51,0 ★	55,2	55,2	55,2 ★		59,4	59,4 ★	63,6 ★	70,0 ★		
3,0														3,0
3,5														3,5
4,0														4,0
4,5														4,5
5,0														5,0
5,5														5,5
6,0														6,0
7,0														7,0
8,0														8,0
9,0														9,0
10,0														10,0
11,0	13,5	15,5	18,0	20,0										11,0
12,0	13,0	14,5	17,0	19,5	13,0	14,0	15,5							12,0
14,0	11,3	13,0	15,5	17,5	11,5	13,0	14,5		11,0	12,0				14,0
16,0	10,0	11,5	13,8	15,4	10,5	12,0	13,5		10,5	11,5	9,5			16,0
18,0	9,0	10,4	12,4	13,6	9,5	11,0	12,5		9,6	11,0	9,2	7,0		18,0
20,0	8,0	9,3	11,0	11,8	8,5	9,8	11,2		9,0	10,2	9,0	7,0		20,0
22,0	7,2	8,4	10,0	9,8	7,8	9,0	10,2		8,2	9,3	8,4	6,8		22,0
24,0	6,5	7,6	9,0	8,3	7,0	8,2	8,5		7,5	8,5	7,8	6,5		24,0
26,0	6,0	6,9	7,5	7,0	6,4	7,6	7,2		6,9	7,5	7,2	6,2		26,0
28,0	5,5	6,3	6,5	6,0	5,9	6,9	6,2		6,4	6,3	6,6	5,9		28,0
30,0	5,0	5,7	5,7	5,0	5,4	5,9	5,3		5,9	5,6	6,0	5,6		30,0
32,0	4,5	5,2	4,8	4,2	5,0	5,1	4,5		5,5	4,8	5,0	5,2		32,0
34,0	4,2	4,8	4,1	3,5	4,6	4,4	3,8		4,7	4,1	4,4	4,5		34,0
36,0	4,9	4,1	3,5	2,9	4,2	3,7	3,1		4,1	3,5	3,8	3,9		36,0
38,0	3,6	3,6	2,9	2,3	3,9	3,2	2,6		3,5	2,9	3,2	3,3		38,0
40,0	3,3	3,2	2,5	1,9	3,4	2,7	2,1		3,0	2,4	2,8	2,9		40,0
42,0	3,1	2,8	2,1	1,5	3,0	2,3	1,7		2,6	2,0	2,4	2,5		42,0
44,0	2,7	2,4	1,7	1,1	2,6	1,9	1,3		2,2	1,6	2,0	2,1		44,0
46,0					2,3	1,6	1,0		1,9	1,3	1,6	1,7		46,0
48,0									1,6	1,0	1,3	1,4		48,0
50,0											1,0	1,1		50,0
Passagem	4				3					3		3	3	Passagem
Gancho	60t												Gancho	
Modo telescópico	I	1	1	2	3	1	2	3		2	3	3	4	I
	II	2	3	3	3	3	3	3		3	3	3	4	II
	III	3	3	3	3	3	3	3		3	3	3	4	III
	IV	3	3	3	2	3	3	3		3	3	3	4	IV
	V	3	3	2	2	3	3	2		3	3	3	4	V
	VI	3	2	2	2	3	2	2		3	2	3	4	VI

Descrição do Guindaste

Tabela 1-15 Tabela de capacidade de elevação (apenas com lança principal)

Unidade: tonelada

Estabilizadores totalmente estendidos para 8m, contrapeso de 19t, sobre a área de trabalho lateral ou traseira														
RAIO DE TRABALHO (m)	Comprimento de lança (m)												Raio de trabalho (m)	
	13,2 ★	17,4	17,4	17,4	17,4	17,4	17,4 ★	21,6	21,6	21,6	21,6	21,6		21,6 ★
3,0	100,0	40,5	66,0	72,0	72,0	72,0	72,0	29,5	44,0	65,0	68,0	68,0	68,0	3,0
3,5	86,0	38,0	61,0	72,0	72,0	72,0	72,0	28,0	42,0	60,0	66,0	67,0	67,0	3,5
4,0	80,0	36,0	56,5	71,0	71,0	71,0	71,0	26,0	40,0	55,0	65,0	66,0	66,0	4,0
4,5	75,0	34,5	52,5	70,0	70,0	70,0	70,0	24,0	38,0	52,0	63,5	65,0	65,0	4,5
5,0	68,0	33,0	49,0	65,0	66,0	66,0	66,0	23,0	36,0	49,0	60,0	63,0	63,0	5,0
5,5	62,0	31,5	46,0	61,0	62,0	62,0	62,0	22,0	34,0	46,0	56,0	60,0	60,0	5,5
6,0	57,0	30,0	43,0	57,5	59,0	59,0	59,0	21,0	31,5	43,0	53,0	57,0	57,0	6,0
7,0	48,0	27,5	38,5	49,0	49,0	48,0	48,0	19,0	29,0	39,0	45,0	48,0	48,0	7,0
8,0	42,0	25,5	35,0	42,0	41,5	41,0	41,0	17,0	26,5	36,0	40,0	40,5	40,5	8,0
9,0	35,0	24,0	32,0	37,5	37,0	36,0	36,0	16,0	24,5	33,0	36,0	36,0	35,0	9,0
10,0		22,5	29,5	33,5	33,0	32,0	32,0	15,0	22,5	30,0	32,5	31,5	30,5	10,0
11,0		21,5	27,0	29,0	28,5	27,5	27,5	13,9	21,0	28,0	29,0	28,0	27,0	11,0
12,0		20,3	25,0	24,5	24,0	23,0	23,0	13,0	19,5	26,0	25,0	24,0	23,0	12,0
14,0								11,5	17,0	20,0	19,0	18,0	17,0	14,0
16,0								10,4	15,0	16,0	15,0	14,0	13,0	16,0
18,0														18,0
20,0														20,0
22,0														22,0
24,0														24,0
26,0														26,0
28,0														28,0
30,0														30,0
32,0														32,0
34,0														34,0
36,0														36,0
38,0														38,0
40,0														40,0
42,0														42,0
44,0														44,0
46,0														46,0
Passagem	12	12					12					Passagem		
Gancho	60t												Gancho	
Modo telescópico	I	1	1	1	1	1	1	1	1	1	1	1	2	I
	II	1	1	1	1	1	2	1	1	1	1	2	2	II
	III	1	1	1	1	2	1	1	1	1	2	2	1	III
	IV	1	1	1	2	1	1	1	1	2	2	1	1	IV
	V	1	1	2	1	1	1	1	2	2	1	1	1	V
	VI	1	2	1	1	1	1	3	2	1	1	1	1	VI

Tabela 1-16 Tabela de capacidade de elevação (apenas com lança principal)

Unidade: tonelada

Estabilizadores totalmente estendidos para 8m, contrapeso de 19t, sobre a área de trabalho lateral ou traseira														
RAIO DE TRABALHO (m)	Comprimento de lança (m)													Raio de trabalho (m)
	25,8	25,8	25,8	25,8	25,8	25,8 ★	30,0	30,0	30,0	30,0	30,0	30,0	30,0 ★	
3,0														3,0
3,5														3,5
4,0	25,0	25,0	43,0	60,0	60,0	60,0								4,0
4,5	23,5	23,5	41,0	56,0	60,0	60,0								4,5
5,0	22,0	22,0	39,5	53,0	60,0	60,0	19,0	24,0	26,0	42,0	53,0	53,0		5,0
5,5	21,0	21,0	38,0	50,0	58,0	58,0	18,5	23,0	24,5	40,5	51,5	51,5		5,5
6,0	20,0	20,0	36,0	47,0	54,0	54,0	17,5	22,0	23,0	39,5	50,0	50,0		6,0
7,0	18,0	18,0	33,0	42,0	46,0	46,0	15,8	20,0	21,0	36,0	48,0	48,0		7,0
8,0	16,5	16,5	30,0	38,0	41,0	41,0	14,3	18,5	19,0	33,5	44,0	44,0		8,0
9,0	15,0	15,0	28,0	35,0	37,0	37,0	13,0	17,0	17,5	31,0	40,0	38,0		9,0
10,0	14,0	14,0	26,0	32,0	32,5	31,0	12,0	15,5	16,0	28,5	35,0	33,0		10,0
11,0	13,0	13,0	24,5	30,0	28,5	27,0	11,0	14,5	15,0	27,0	29,0	27,5		11,0
12,0	12,0	12,0	22,5	26,5	25,5	24,0	10,3	13,5	14,0	25,0	26,0	24,5		12,0
14,0	10,5	10,5	20,0	20,5	19,5	18,0	9,0	11,9	12,2	21,0	20,0	18,5		14,0
16,0	9,4	9,3	17,3	16,5	15,5	14,0	8,0	10,7	10,7	17,2	16,2	14,7		16,0
18,0	8,5	8,4	14,2	13,4	12,4	10,9	7,1	9,6	9,6	14,3	13,3	11,8		18,0
20,0	7,7	7,6	11,9	11,1	10,1	8,6	6,4	8,7	8,7	11,9	10,9	9,5		20,0
22,0							5,8	8,0	7,9	10,0	9,0	7,7		22,0
24,0							5,3	7,3	7,2	8,5	7,5	6,2		24,0
26,0														26,0
28,0														28,0
30,0														30,0
32,0														32,0
34,0														34,0
36,0														36,0
38,0														38,0
40,0														40,0
42,0														42,0
44,0														44,0
46,0														46,0
Passagem	11						9						Passagem	
Gancho	60t													Gancho
Modo telescópico	I	1	1	1	1	1	2	1	1	1	1	1	2	I
	II	1	1	1	1	2	2	1	1	1	1	2	2	II
	III	1	1	1	2	2	2	1	1	1	2	2	2	III
	IV	1	1	2	2	2	1	1	2	3	2	2	2	IV
	V	2	3	2	2	1	1	3	3	2	2	2	1	V
	VI	3	2	2	1	1	1	3	2	2	2	1	1	VI
														Modo telescópico

Descrição do Guindaste

Tabela 1-17 Tabela de capacidade de elevação (apenas com lança principal)

Unidade: tonelada

Estabilizadores totalmente estendidos para 8m, contrapeso de 19t, sobre a área de trabalho lateral ou traseira														
RAIO DE TRABALHO (m)	Comprimento de lança (m)												RAIO DE TRABALHO (m)	
	34,2	34,2	34,2	34,2	34,2	34,2 ★	38,4	38,4	38,4	38,4	38,4	38,4 ★		
3,0														3,0
3,5														3,5
4,0														4,0
4,5														4,5
5,0														5,0
5,5														5,5
6,0	19,0	21,5	25,5	26,0	43,0	46,0								6,0
7,0	17,0	19,0	23,0	23,5	40,5	44,0	17,0	20,0	21,5	26,0	30,5	41,5		7,0
8,0	15,5	17,5	21,0	21,5	38,0	42,0	15,5	18,5	19,5	24,0	28,0	39,0		8,0
9,0	14,5	16,0	19,5	19,5	35,0	38,0	14,0	17,0	18,0	22,0	25,5	36,0		9,0
10,0	13,3	14,5	18,0	18,0	32,5	33,0	13,0	15,7	16,5	20,3	23,5	33,5		10,0
11,0	12,3	13,5	16,5	16,5	30,5	30,0	12,0	14,5	15,2	18,8	22,0	31,0		11,0
12,0	11,5	12,5	15,5	15,5	27,5	26,0	11,0	13,5	14,0	17,5	20,5	27,0		12,0
14,0	10,1	10,8	13,5	13,5	21,3	19,8	9,5	11,7	12,2	15,4	17,7	20,7		14,0
16,0	8,9	9,6	11,8	11,8	17,0	15,6	8,5	10,4	10,8	13,6	15,7	16,4		16,0
18,0	8,0	8,5	10,5	10,5	14,0	12,6	7,5	9,3	9,6	12,1	13,6	13,3		18,0
20,0	7,2	7,7	9,5	9,4	11,6	10,3	6,7	8,4	8,6	11,0	11,5	11,0		20,0
22,0	6,5	6,9	8,6	8,5	9,8	8,4	6,0	7,6	7,7	9,7	9,6	9,1		22,0
24,0	6,0	6,3	7,9	7,8	8,3	7,0	5,5	6,9	7,0	8,0	8,0	7,6		24,0
26,0	5,5	5,7	7,2	7,1	7,0	5,7	5,0	6,3	6,3	7,1	6,8	6,4		26,0
28,0	5,1	5,3	6,4	6,2	6,0	4,7	4,5	5,8	5,8	6,0	5,8	5,4		28,0
30,0							4,2	5,3	5,3	5,0	4,8	4,5		30,0
32,0							3,9	4,8	4,8	4,4	4,2	3,8		32,0
34,0														34,0
36,0														36,0
38,0														38,0
40,0														40,0
42,0														42,0
44,0														44,0
46,0														46,0
Passagem	8						7						Passagem	
Gancho	60t												Gancho	
Modo telescópico	I	1	1	1	1	1	2	1	1	1	1	1	2	I
	II	1	1	1	1	2	2	1	1	1	2	3	2	II
	III	1	1	2	3	2	2	1	2	3	3	2	2	III
	IV	2	3	3	2	2	2	3	3	3	2	2	2	IV
	V	3	3	2	2	2	2	3	3	2	2	2	2	V
	VI	3	2	2	2	2	1	3	2	2	2	2	2	VI

Tabela 1-18 Tabela de capacidade de elevação (apenas com lança principal)

Unidade: tonelada

Estabilizadores totalmente estendidos para 8m, contrapeso de 19t, sobre a área de trabalho lateral ou traseira														
RAIO DE TRABALHO (m)	Comprimento de lança (m)												RAIO DE TRABALHO (m)	
	42,6	42,6	42,6	42,6	42,6	42,6★		46,8	46,8	46,8	46,8	46,8★		
3,0														3,0
3,5														3,5
4,0														4,0
4,5														4,5
5,0														5,0
5,5														5,5
6,0														6,0
7,0														7,0
8,0	16,5	18,0	21,5	26,0	30,0	32,5								8,0
9,0	15,0	16,5	20,0	24,0	28,0	30,0								9,0
10,0	14,0	15,0	18,5	22,0	26,0	28,0		14,0	16,5	19,5	23,0	25,0		10,0
11,0	12,9	14,0	17,0	20,3	24,0	26,0		12,8	15,3	18,0	21,3	23,5		11,0
12,0	12,0	12,9	15,8	18,8	22,3	24,0		11,9	14,2	16,8	19,8	22,0		12,0
14,0	10,4	11,0	13,8	16,3	19,5	20,0		10,3	12,3	14,6	17,4	19,0		14,0
16,0	9,2	9,8	12,2	14,4	16,0	15,8		9,0	10,9	13,0	15,4	15,8		16,0
18,0	8,2	8,6	10,8	12,7	13,0	12,8		8,0	9,6	11,5	13,2	12,8		18,0
20,0	7,3	7,7	9,7	11,3	10,8	10,5		7,1	8,6	10,2	11,0	10,4		20,0
22,0	6,6	6,9	8,7	9,6	9,0	8,7		6,4	7,7	9,2	9,2	8,6		22,0
24,0	6,0	6,2	7,9	8,1	7,5	7,1		5,7	7,0	8,3	7,7	7,1		24,0
26,0	5,5	5,6	7,2	6,9	6,3	5,9		5,2	6,4	7,0	6,4	5,9		26,0
28,0	5,0	5,1	6,2	5,9	5,3	4,9		4,7	5,8	6,0	5,4	4,9		28,0
30,0	4,6	4,7	5,4	5,0	4,4	4,0		4,3	5,3	5,2	4,5	4,0		30,0
32,0	4,3	4,3	4,6	4,2	3,7	3,3		4,0	4,7	4,4	3,8	3,3		32,0
34,0	4,0	3,9	4,0	3,6	3,1	2,7		3,6	4,2	3,8	3,2	2,6		34,0
36,0	3,7	3,6	3,4	3,0	2,5	2,1		3,3	3,7	3,3	2,6	2,1		36,0
38,0								3,0	3,2	2,8	2,1	1,6		38,0
40,0								2,8	2,8	2,3	1,6	1,1		40,0
42,0														42,0
44,0														44,0
46,0														46,0
Passagem	6						5						Passagem	
Gancho	60t												Gancho	
Modo telescópico	I	1	1	1	1	2	3		1	1	1	2	3	I
	II	1	1	2	3	3	2		1	2	3	3	3	II
	III	2	3	3	3	2	2		3	3	3	3	2	III
	IV	3	3	3	2	2	2		3	3	3	2	2	IV
	V	3	3	2	2	2	2		3	3	2	2	2	V
	VI	3	2	2	2	2	2		3	2	2	2	2	VI

Descrição do Guindaste

Tabela 1-19 Tabela de capacidade de elevação (apenas com lança principal)

Unidade: tonelada

Estabilizadores totalmente estendidos para 8m, contrapeso de 19t, sobre a área de trabalho lateral ou traseira															
RAIO DE TRABALHO (m)	Comprimento de lança (m)												RAIO DE TRABALHO (m)		
	51,0	51,0	51,0	51,0 ★	55,2	55,2	55,2 ★		59,4	59,4 ★	63,6 ★	70,0 ★			
3,0														3,0	
3,5														3,5	
4,0														4,0	
4,5														4,5	
5,0														5,0	
5,5														5,5	
6,0														6,0	
7,0														7,0	
8,0														8,0	
9,0														9,0	
10,0														10,0	
11,0	13,5	15,5	18,0	20,0										11,0	
12,0	13,0	14,5	17,0	19,5	13,0	14,0	15,5							12,0	
14,0	11,3	13,0	15,5	17,5	11,5	13,0	14,5		11,0	12,0				14,0	
16,0	10,0	11,5	13,8	15,4	10,5	12,0	13,5		10,5	11,5	9,5			16,0	
18,0	9,0	10,4	12,4	13,0	9,5	11,0	12,5		9,6	11,0	9,2	7,0		18,0	
20,0	8,0	9,3	11,0	10,7	8,5	9,8	11,0		9,0	10,2	9,0	7,0		20,0	
22,0	7,2	8,4	9,5	8,8	7,8	9,0	9,1		8,2	9,3	8,4	6,8		22,0	
24,0	6,5	7,6	7,9	7,3	7,0	8,2	7,6		7,5	8,0	7,8	6,5		24,0	
26,0	6,0	6,9	6,7	6,0	6,4	7,0	6,3		6,9	6,7	7,1	6,2		26,0	
28,0	5,5	6,3	5,7	5,0	5,9	6,0	5,3		6,2	5,6	6,0	5,9		28,0	
30,0	5,0	5,5	4,8	4,1	5,4	5,1	4,4		5,5	4,8	5,2	5,3		30,0	
32,0	4,5	4,7	4,0	3,4	5,0	4,3	3,6		4,7	4,0	4,4	4,5		32,0	
34,0	4,2	4,1	3,4	2,8	4,4	3,6	2,9		4,0	3,3	3,8	3,9		34,0	
36,0	4,9	3,5	2,8	2,2	3,8	3,1	2,4		3,5	2,8	3,2	3,3		36,0	
38,0	3,5	3,0	2,3	1,7	3,3	2,6	1,9		3,0	2,3	2,6	2,7		38,0	
40,0	3,0	2,6	1,9	1,3	2,9	2,2	1,5		2,5	1,8	2,2	2,3		40,0	
42,0					2,6	1,8	1,1		2,1	1,4	1,8	1,9		42,0	
44,0									1,8	1,1	1,4	1,5		44,0	
46,0											1,1	1,2		46,0	
Passagem	4				3					3		3	3	Passagem	
Gancho	60t												Gancho		
Modo telescópico	I	1	1	2	3	1	2	3		2	3	3	4	I	Modo telescópico
	II	2	3	3	3	3	3	3		3	3	3	4	II	
	III	3	3	3	3	3	3	3		3	3	3	4	III	
	IV	3	3	3	2	3	3	3		3	3	3	4	IV	
	V	3	3	2	2	3	3	2		3	3	3	4	V	
	VI	3	2	2	2	3	2	2		3	2	3	4	VI	

Tabela 1-20 Tabela de capacidade de elevação (apenas com lança principal)

Unidade: tonelada

Estabilizadores totalmente estendidos para 8m, contrapeso de 15t, sobre a área de trabalho lateral ou traseira														
RAIO DE TRABALHO (m)	Comprimento de lança (m)												RAIO DE TRABALHO (m)	
	13,2 ★	17,4	17,4	17,4	17,4	17,4 ★	21,6	21,6	21,6	21,6	21,6	21,6 ★		
3,0	100,0	40,5	66,0	72,0	72,0	72,0	29,5	44,0	65,0	68,0	68,0	68,0	3,0	
3,5	86,0	38,0	61,0	72,0	72,0	72,0	28,0	42,0	60,0	66,0	67,0	67,0	3,5	
4,0	80,0	36,0	56,5	71,0	71,0	71,0	26,0	40,0	55,0	65,0	66,0	66,0	4,0	
4,5	75,0	34,5	52,5	70,0	70,0	70,0	24,0	38,0	52,0	63,5	65,0	65,0	4,5	
5,0	68,0	33,0	49,0	65,0	66,0	66,0	23,0	36,0	49,0	60,0	63,0	63,0	5,0	
5,5	61,0	31,5	46,0	61,0	62,0	62,0	22,0	34,0	46,0	56,0	60,0	60,0	5,5	
6,0	56,0	30,0	43,0	57,5	59,0	59,0	21,0	31,5	43,0	53,0	57,0	57,0	6,0	
7,0	46,0	27,5	38,5	49,0	47,0	47,0	19,0	29,0	39,0	45,0	46,0	46,0	7,0	
8,0	39,0	25,5	35,0	42,0	40,0	39,0	17,0	26,5	36,0	40,0	41,0	39,0	8,0	
9,0	33,5	24,0	32,0	36,0	35,0	34,0	16,0	24,5	33,0	36,0	34,5	33,0	9,0	
10,0		22,5	29,5	31,0	30,5	29,5	15,0	22,5	30,0	30,0	28,5	27,0	10,0	
11,0		21,5	26,5	26,5	26,0	25,0	13,9	21,0	27,0	26,0	24,5	23,0	11,0	
12,0		20,3	23,0	22,5	22,0	21,0	13,0	19,5	23,5	22,5	21,5	20,0	12,0	
14,0							11,5	17,0	18,5	17,5	16,5	15,0	14,0	
16,0							10,4	14,5	14,5	13,5	12,5	11,5	16,0	
18,0													18,0	
20,0													20,0	
22,0													22,0	
24,0													24,0	
26,0													26,0	
28,0													28,0	
30,0													30,0	
32,0													32,0	
34,0													34,0	
36,0													36,0	
38,0													38,0	
40,0													40,0	
42,0													42,0	
Passagem	12	12					12					Passagem		
Gancho	60t												Gancho	
Modo telescópico	I	1	1	1	1	1	1	1	1	1	1	1	2	I
	II	1	1	1	1	1	2	1	1	1	1	2	2	II
	III	1	1	1	1	2	1	1	1	1	2	2	1	III
	IV	1	1	1	2	1	1	1	1	2	2	1	1	IV
	V	1	1	2	1	1	1	1	2	2	1	1	1	V
	VI	1	2	1	1	1	1	3	2	1	1	1	1	VI

Tabela 1-21 Tabela de capacidade de elevação (apenas com lança principal)

Unidade: tonelada

Estabilizadores totalmente estendidos para 8m, contrapeso de 15t, sobre a área de trabalho lateral ou traseira														
RAIO DE TRABALHO (m)	Comprimento de lança (m)												RAIO DE TRABALHO (m)	
	25,8	25,8	25,8	25,8	25,8	25,8 ★	30,0	30,0	30,0	30,0	30,0	30,0		30,0 ★
3,0														3,0
3,5														3,5
4,0	25,0	25,0	43,0	60,0	60,0	60,0								4,0
4,5	23,5	23,5	41,0	56,0	60,0	60,0								4,5
5,0	22,0	22,0	39,5	53,0	60,0	60,0	19,0	24,0	26,0	42,0	53,0	53,0		5,0
5,5	21,0	21,0	38,0	50,0	58,0	58,0	18,5	23,0	24,5	40,5	51,5	51,5		5,5
6,0	20,0	20,0	36,0	47,0	54,0	54,0	17,5	22,0	23,0	39,5	50,0	50,0		6,0
7,0	18,0	18,0	33,0	42,0	46,0	46,0	15,8	20,0	21,0	36,0	48,0	48,0		7,0
8,0	16,5	16,5	30,0	38,0	40,0	40,0	14,3	18,5	19,0	33,5	44,0	44,0		8,0
9,0	15,0	15,0	28,0	35,0	35,0	33,0	13,0	17,0	17,5	31,0	37,0	35,0		9,0
10,0	14,0	14,0	26,0	32,0	31,0	29,0	12,0	15,5	16,0	28,5	31,0	29,0		10,0
11,0	13,0	13,0	24,5	27,5	26,5	24,5	11,0	14,5	15,0	27,0	27,0	25,0		11,0
12,0	12,0	12,0	22,5	24,0	23,0	21,0	10,3	13,5	14,0	25,0	24,0	22,0		12,0
14,0	10,5	10,5	19,5	18,7	17,7	16,0	9,0	11,9	12,2	19,5	18,5	16,5		14,0
16,0	9,4	9,3	15,5	14,7	13,7	12,3	8,0	10,7	10,7	15,5	14,5	13,0		16,0
18,0	8,5	8,4	12,7	11,9	10,9	9,5	7,1	9,6	9,6	12,7	11,7	10,2		18,0
20,0	7,7	7,6	10,5	9,7	8,7	7,3	6,4	8,7	8,7	10,5	9,5	8,0		20,0
22,0							5,8	8,0	7,9	8,7	7,7	6,3		22,0
24,0							5,3	7,3	7,2	7,4	6,4	5,0		24,0
26,0														26,0
28,0														28,0
30,0														30,0
32,0														32,0
34,0														34,0
36,0														36,0
38,0														38,0
40,0														40,0
42,0														42,0
Passagem	11						9						Passagem	
Gancho	60t												Gancho	
Modo telescópico	I	1	1	1	1	1	2	1	1	1	1	1	2	I
	II	1	1	1	1	2	2	1	1	1	1	2	2	II
	III	1	1	1	2	2	2	1	1	1	2	2	2	III
	IV	1	1	2	2	2	1	1	2	3	2	2	2	IV
	V	2	3	2	2	1	1	3	3	2	2	2	1	V
	VI	3	2	2	1	1	1	3	2	2	2	1	1	VI
														Modo telescópico

Tabela 1-22 Tabela de capacidade de elevação (apenas com lança principal)

Unidade: tonelada

Estabilizadores totalmente estendidos para 8m, contrapeso de 15t, sobre a área de trabalho lateral ou traseira														
RAIO DE TRABALHO (m)	Comprimento de lança (m)												RAIO DE TRABALHO (m)	
	34,2	34,2	34,2	34,2	34,2	34,2 ★	38,4	38,4	38,4	38,4	38,4	38,4		38,4 ★
3,0														3,0
3,5														3,5
4,0														4,0
4,5														4,5
5,0														5,0
5,5														5,5
6,0	19,0	21,5	25,5	26,0	43,0	46,0								6,0
7,0	17,0	19,0	23,0	23,5	40,5	44,0	17,0	20,0	21,5	26,0	30,5	41,5		7,0
8,0	15,5	17,5	21,0	21,5	38,0	42,0	15,5	18,5	19,5	24,0	28,0	39,0		8,0
9,0	14,5	16,0	19,5	19,5	35,0	36,0	14,0	17,0	18,0	22,0	25,5	36,0		9,0
10,0	13,3	14,5	18,0	18,0	32,5	32,5	13,0	15,7	16,5	20,3	23,5	32,5		10,0
11,0	12,3	13,5	16,5	16,5	28,5	27,0	12,0	14,5	15,2	18,8	22,0	28,0		11,0
12,0	11,5	12,5	15,5	15,5	25,0	23,5	11,0	13,5	14,0	17,5	20,5	24,0		12,0
14,0	10,1	10,8	13,5	13,5	19,3	17,8	9,5	11,7	12,2	15,4	17,7	18,5		14,0
16,0	8,9	9,6	11,8	11,8	15,3	13,9	8,5	10,4	10,8	13,6	15,1	14,5		16,0
18,0	8,0	8,5	10,5	10,5	12,5	10,9	7,5	9,3	9,6	12,1	12,2	11,8		18,0
20,0	7,2	7,7	9,5	9,4	10,3	8,7	6,7	8,4	8,6	10,2	10,0	9,6		20,0
22,0	6,5	6,9	8,6	8,5	8,5	7,1	6,0	7,6	7,7	8,5	8,3	7,9		22,0
24,0	6,0	6,3	7,5	7,3	7,1	5,8	5,5	6,9	7,0	7,2	7,0	6,5		24,0
26,0	5,5	5,7	6,4	6,2	6,0	4,7	5,0	6,3	6,3	6,0	5,8	5,4		26,0
28,0	5,1	5,3	5,5	5,3	5,0	3,8	4,5	5,8	5,5	5,1	4,9	4,5		28,0
30,0							4,2	5,0	4,7	4,3	4,1	3,7		30,0
32,0							3,9	4,3	4,0	3,6	3,4	3,0		32,0
34,0														34,0
36,0														36,0
38,0														38,0
40,0														40,0
42,0														42,0
Passagem	8						7						Passagem	
Gancho	60t												Gancho	
Modo telescópico	I	1	1	1	1	1	2	1	1	1	1	1	2	Modo telescópico
	II	1	1	1	1	2	2	1	1	1	2	3	2	
	III	1	1	2	3	2	2	1	2	3	3	2	2	
	IV	2	3	3	2	2	2	3	3	3	2	2	2	
	V	3	3	2	2	2	2	3	3	2	2	2	2	
	VI	3	2	2	2	2	1	3	2	2	2	2	2	

Tabela 1-23 Tabela de capacidade de elevação (apenas com lança principal)

Unidade: tonelada

Estabilizadores totalmente estendidos para 8m, contrapeso de 15t, sobre a área de trabalho lateral ou traseira														
RAIO DE TRABALHO (m)	Comprimento de lança (m)												RAIO DE TRABALHO (m)	
	42,6	42,6	42,6	42,6	42,6	42,6 ★		46,8	46,8	46,8	46,8	46,8 ★		
3,0														3,0
3,5														3,5
4,0														4,0
4,5														4,5
5,0														5,0
5,5														5,5
6,0														6,0
7,0														7,0
8,0	16,5	18,0	21,5	26,0	30,0	32,5								8,0
9,0	15,0	16,5	20,0	24,0	28,0	30,0								9,0
10,0	14,0	15,0	18,5	22,0	26,0	28,0		14,0	16,5	19,5	23,0	25,0		10,0
11,0	12,9	14,0	17,0	20,3	24,0	26,0		12,8	15,3	18,0	21,3	23,5		11,0
12,0	12,0	12,9	15,8	18,8	22,3	23,8		11,9	14,2	16,8	19,8	22,0		12,0
14,0	10,4	11,0	13,8	16,3	18,5	18,1		10,3	12,3	14,6	17,4	18,0		14,0
16,0	9,2	9,8	12,2	14,4	14,6	14,2		9,0	10,9	13,0	14,8	14,0		16,0
18,0	8,2	8,6	10,8	12,4	11,8	11,3		8,0	9,6	11,5	11,9	11,3		18,0
20,0	7,3	7,7	9,7	10,2	9,5	9,1		7,1	8,6	10,2	9,7	9,1		20,0
22,0	6,6	6,9	8,7	8,4	7,8	7,3		6,4	7,7	8,6	7,9	7,4		22,0
24,0	6,0	6,2	7,4	7,0	6,4	6,0		5,7	7,0	7,2	6,5	6,0		24,0
26,0	5,5	5,6	6,2	5,9	5,2	4,9		5,2	6,4	6,1	5,4	4,9		26,0
28,0	5,0	5,1	5,3	4,9	4,3	4,0		4,7	5,6	5,2	4,5	4,0		28,0
30,0	4,6	4,7	4,5	4,2	3,5	3,2		4,3	4,8	4,3	3,6	3,2		30,0
32,0	4,3	4,3	3,8	3,5	2,8	2,5		4,0	4,1	3,6	2,9	2,5		32,0
34,0	4,0	3,6	3,2	2,9	2,2	1,9		3,6	3,6	3,1	2,4	1,9		34,0
36,0	3,5	3,1	2,7	2,4	1,8	1,4		3,3	3,0	2,6	1,9	1,4		36,0
38,0								3,0	2,5	2,1	1,4	0,9		38,0
40,0														40,0
42,0														42,0
Passagem	6							5						Passagem
Gancho	60t												Gancho	
Modo telescópico	I	1	1	1	1	2	3		1	1	1	2	3	I
	II	1	1	2	3	3	2		1	2	3	3	3	II
	III	2	3	3	3	2	2		3	3	3	3	2	III
	IV	3	3	3	2	2	2		3	3	3	2	2	IV
	V	3	3	2	2	2	2		3	3	2	2	2	V
	VI	3	2	2	2	2	2		3	2	2	2	2	VI

Tabela 1-24 Tabela de capacidade de elevação (apenas com lança principal)

Unidade: tonelada

Estabilizadores totalmente estendidos para 8m, contrapeso de 15t, sobre a área de trabalho lateral ou traseira														
RAIO DE TRABALHO (m)	Comprimento de lança (m)												RAIO DE TRABALHO (m)	
	51,0	51,0	51,0	51,0 ★	55,2	55,2	55,2 ★		59,4	59,4 ★	63,6 ★	70,0 ★		
3,0														3,0
3,5														3,5
4,0														4,0
4,5														4,5
5,0														5,0
5,5														5,5
6,0														6,0
7,0														7,0
8,0														8,0
9,0														9,0
10,0														10,0
11,0	13,5	15,5	18,0	20,0										11,0
12,0	13,0	14,5	17,0	19,5	13,0	14,0	15,5							12,0
14,0	11,3	13,0	15,5	17,5	11,5	13,0	14,5		11,0	12,0				14,0
16,0	10,0	11,5	13,8	14,3	10,5	12,0	13,5		10,5	11,5	9,5			16,0
18,0	9,0	10,4	12,2	11,5	9,5	11,0	11,5		9,6	11,0	9,2	7,0		18,0
20,0	8,0	9,3	10,0	9,3	8,5	9,8	9,5		9,0	9,8	9,0	7,0		20,0
22,0	7,2	8,4	8,2	7,5	7,8	8,5	7,8		8,2	8,2	8,4	6,8		22,0
24,0	6,5	7,5	6,8	6,1	7,0	7,1	6,4		7,5	6,8	7,1	6,5		24,0
26,0	6,0	6,4	5,6	5,0	6,4	6,0	5,3		6,4	5,7	6,0	6,1		26,0
28,0	5,5	5,5	4,7	4,0	5,8	5,0	4,3		5,4	4,7	5,1	5,2		28,0
30,0	5,0	4,7	3,9	3,3	5,0	4,2	3,5		4,6	3,9	4,3	4,4		30,0
32,0	4,4	4,0	3,2	2,6	4,3	3,5	2,8		3,9	3,2	3,6	3,7		32,0
34,0	3,8	3,4	2,6	2,0	3,7	3,0	2,3		3,3	2,6	3,0	3,1		34,0
36,0	3,3	2,9	2,1	1,5	3,2	2,5	1,8		2,8	2,1	2,4	2,5		36,0
38,0	2,9	2,4	1,6	1,0	2,7	2,0	1,3		2,3	1,6	1,9	2,0		38,0
40,0									1,9	1,2	1,5	1,6		40,0
42,0											1,2	1,3		42,0
Passagem	4				3					3		3	3	Passagem
Gancho	60t												Gancho	
Modo telescópico	I	1	1	2	3	1	2	3		2	3	3	4	I
	II	2	3	3	3	3	3	3		3	3	3	4	II
	III	3	3	3	3	3	3	3		3	3	3	4	III
	IV	3	3	3	2	3	3	3		3	3	3	4	IV
	V	3	3	2	2	3	3	2		3	3	3	4	V
	VI	3	2	2	2	3	2	2		3	2	3	4	VI

Tabela 1-25 Tabela de capacidade de elevação (apenas com lança principal)

Unidade: tonelada

Estabilizadores totalmente estendidos para 8m, contrapeso de 11t, sobre a área de trabalho lateral ou traseira														
RAIO DE TRABALHO (m)	Comprimento de lança (m)												RAIO DE TRABALHO (m)	
	13,2 ★	17,4	17,4	17,4	17,4	17,4 ★	21,6	21,6	21,6	21,6	21,6	21,6 ★		
3,0	100,0	40,5	66,0	72,0	72,0	72,0	29,5	44,0	65,0	68,0	68,0	68,0	3,0	
3,5	86,0	38,0	61,0	72,0	72,0	72,0	28,0	42,0	60,0	66,0	67,0	67,0	3,5	
4,0	80,0	36,0	56,5	71,0	71,0	71,0	26,0	40,0	55,0	65,0	66,0	66,0	4,0	
4,5	73,0	34,5	52,5	70,0	70,0	70,0	24,0	38,0	52,0	63,5	65,0	65,0	4,5	
5,0	62,0	33,0	49,0	65,0	66,0	66,0	23,0	36,0	49,0	60,0	63,0	63,0	5,0	
5,5	58,0	31,5	46,0	61,0	62,0	62,0	22,0	34,0	46,0	56,0	60,0	60,0	5,5	
6,0	53,0	30,0	43,0	53,5	54,0	54,0	21,0	31,5	43,0	53,0	53,0	53,0	6,0	
7,0	44,0	27,5	38,5	44,0	45,0	45,0	19,0	29,0	39,0	45,0	44,0	44,0	7,0	
8,0	37,0	25,5	35,0	40,0	39,0	38,0	17,0	26,5	36,0	40,0	39,0	37,0	8,0	
9,0	31,0	24,0	32,0	31,5	31,0	30,0	16,0	24,5	33,0	32,0	31,0	29,0	9,0	
10,0		22,5	26,0	25,5	25,0	24,0	15,0	22,5	29,0	27,0	26,0	24,0	10,0	
11,0		21,5	22,0	21,5	21,0	20,0	13,9	21,0	25,0	23,0	22,0	21,0	11,0	
12,0		20,3	19,0	18,5	18,0	17,0	13,0	19,5	21,5	20,0	19,0	17,5	12,0	
14,0							11,5	17,0	16,5	15,5	14,5	13,0	14,0	
16,0							10,4	13,4	12,8	11,8	11,0	9,5	16,0	
18,0													18,0	
20,0													20,0	
22,0													22,0	
24,0													24,0	
26,0													26,0	
28,0													28,0	
30,0													30,0	
32,0													32,0	
34,0													34,0	
36,0													36,0	
38,0													38,0	
40,0													40,0	
Passagem	12	12					12					Passagem		
Gancho	60t												Gancho	
Modo telescópico	I	1	1	1	1	1	1	1	1	1	1	1	2	I
	II	1	1	1	1	1	2	1	1	1	1	2	2	II
	III	1	1	1	1	2	1	1	1	1	2	2	1	III
	IV	1	1	1	2	1	1	1	1	2	2	1	1	IV
	V	1	1	2	1	1	1	1	2	2	1	1	1	V
	VI	1	2	1	1	1	1	3	2	1	1	1	1	VI

Tabela 1-26 Tabela de capacidade de elevação (apenas com lança principal)

Unidade: tonelada

Estabilizadores totalmente estendidos para 8m, contrapeso de 11t, sobre a área de trabalho lateral ou traseira														
RAIO DE TRABALHO (m)	Comprimento de lança (m)												RAIO DE TRABALHO (m)	
	25,8	25,8	25,8	25,8	25,8	25,8★	30,0	30,0	30,0	30,0	30,0	30,0		
3,0														3,0
3,5														3,5
4,0	25,0	25,0	43,0	60,0	60,0	60,0								4,0
4,5	23,5	23,5	41,0	56,0	60,0	60,0								4,5
5,0	22,0	22,0	39,5	53,0	60,0	60,0	19,0	24,0	26,0	42,0	53,0	53,0		5,0
5,5	21,0	21,0	38,0	50,0	58,0	58,0	18,5	23,0	24,5	40,5	51,5	51,5		5,5
6,0	20,0	20,0	36,0	47,0	54,0	54,0	17,5	22,0	23,0	39,5	50,0	50,0		6,0
7,0	18,0	18,0	33,0	42,0	46,0	46,0	15,8	20,0	21,0	36,0	48,0	46,0		7,0
8,0	16,5	16,5	30,0	38,0	40,0	38,0	14,3	18,5	19,0	33,5	44,0	40,0		8,0
9,0	15,0	15,0	28,0	35,0	34,0	32,0	13,0	17,0	17,5	31,0	34,0	32,0		9,0
10,0	14,0	14,0	26,0	29,0	28,0	26,0	12,0	15,5	16,0	28,5	28,0	26,0		10,0
11,0	13,0	13,0	24,5	23,5	22,5	21,0	11,0	14,5	15,0	25,5	24,5	23,0		11,0
12,0	12,0	12,0	22,5	21,5	20,5	19,0	10,3	13,5	14,0	22,0	21,0	19,5		12,0
14,0	10,5	10,5	17,0	16,0	15,0	13,5	9,0	11,9	12,2	17,0	16,0	14,5		14,0
16,0	9,4	9,3	13,7	12,9	12,0	10,5	8,0	10,7	10,7	13,5	12,5	11,0		16,0
18,0	8,5	8,4	11,0	10,2	9,3	7,8	7,1	9,6	9,6	11,0	10,0	8,5		18,0
20,0	7,7	7,6	9,0	8,2	7,3	5,8	6,4	8,7	8,7	9,0	8,0	6,5		20,0
22,0								5,8	7,9	7,8	7,5	6,5	5,0	22,0
24,0								5,3	6,6	6,4	6,2	5,2	3,8	24,0
26,0														26,0
28,0														28,0
30,0														30,0
32,0														32,0
34,0														34,0
36,0														36,0
38,0														38,0
40,0														40,0
Passagem	11						9						Passagem	
Gancho	60t												Gancho	
Modo telescópico	I	1	1	1	1	1	2	1	1	1	1	1	2	I
	II	1	1	1	1	2	2	1	1	1	1	2	2	II
	III	1	1	1	2	2	2	1	1	1	2	2	2	III
	IV	1	1	2	2	2	1	1	2	3	2	2	2	IV
	V	2	3	2	2	1	1	3	3	2	2	2	1	V
	VI	3	2	2	1	1	1	3	2	2	2	1	1	VI

Descrição do Guindaste

Tabela 1-27 Tabela de capacidade de elevação (apenas com lança principal)

Unidade: tonelada

Estabilizadores totalmente estendidos para 8m, contrapeso de 11t, sobre a área de trabalho lateral ou traseira															
RAIO DE TRABALHO (m)	Comprimento de lança (m)												RAIO DE TRABALHO (m)		
	34,2	34,2	34,2	34,2	34,2	34,2 ★	38,4	38,4	38,4	38,4	38,4	38,4 ★			
3,0														3,0	
3,5														3,5	
4,0														4,0	
4,5														4,5	
5,0														5,0	
5,5														5,5	
6,0	19,0	21,5	25,5	26,0	43,0	46,0								6,0	
7,0	17,0	19,0	23,0	23,5	40,5	44,0	17,0	20,0	21,5	26,0	30,5	41,5		7,0	
8,0	15,5	17,5	21,0	21,5	38,0	40,0	15,5	18,5	19,5	24,0	28,0	38,5		8,0	
9,0	14,5	16,0	19,5	19,5	35,0	35,0	14,0	17,0	18,0	22,0	25,5	35,0		9,0	
10,0	13,3	14,5	18,0	18,0	30,5	29,0	13,0	15,7	16,5	20,3	23,5	29,5		10,0	
11,0	12,3	13,5	16,5	16,5	25,5	24,0	12,0	14,5	15,2	18,8	22,0	25,0		11,0	
12,0	11,5	12,5	15,5	15,5	22,5	20,5	11,0	13,5	14,0	17,5	20,5	21,5		12,0	
14,0	10,1	10,8	13,5	13,5	17,3	15,8	9,5	11,7	12,2	15,4	17,0	16,6		14,0	
16,0	8,9	9,6	11,8	11,8	13,6	12,0	8,5	10,4	10,8	13,6	13,4	12,8		16,0	
18,0	8,0	8,5	10,5	10,5	10,9	9,5	7,5	9,3	9,6	11,0	10,7	10,1		18,0	
20,0	7,2	7,7	9,3	9,1	8,8	7,5	6,7	8,4	8,6	8,9	8,6	8,2		20,0	
22,0	6,5	6,9	7,7	7,5	7,2	5,9	6,0	7,6	7,7	7,3	7,0	6,6		22,0	
24,0	6,0	6,3	6,5	6,3	6,0	4,7	5,5	6,8	6,5	6,0	5,8	5,4		24,0	
26,0	5,5	5,7	5,5	5,3	5,0	3,7	5,0	5,8	5,5	5,0	4,8	4,4		26,0	
28,0	5,1	4,9	4,6	4,4	4,1	2,8	4,5	5,0	4,6	4,2	4,0	3,6		28,0	
30,0							4,2	4,2	3,8	3,4	3,2	2,8		30,0	
32,0							3,9	3,6	3,2	2,8	2,6	2,2		32,0	
34,0														34,0	
36,0														36,0	
38,0														38,0	
40,0														40,0	
Passagem Gancho	8						7						Passagem Gancho		
Modo telescópico	60t														Modo telescópico
I	1	1	1	1	1	2	1	1	1	1	1	2	I		
II	1	1	1	1	2	2	1	1	1	2	3	2	II		
III	1	1	2	3	2	2	1	2	3	3	2	2	III		
IV	2	3	3	2	2	2	3	3	3	2	2	2	IV		
V	3	3	2	2	2	2	3	3	2	2	2	2	V		
VI	3	2	2	2	2	1	3	2	2	2	2	2	VI		

Tabela 1-28 Tabela de capacidade de elevação (apenas com lança principal)

Unidade: tonelada

Estabilizadores totalmente estendidos para 8m, contrapeso de 11t, sobre a área de trabalho lateral ou traseira															
RAIO DE TRABALHO (m)	Comprimento de lança (m)												RAIO DE TRABALHO (m)		
	42,6	42,6	42,6	42,6	42,6	42,6 ★		46,8	46,8	46,8	46,8	46,8 ★			
3,0														3,0	
3,5														3,5	
4,0														4,0	
4,5														4,5	
5,0														5,0	
5,5														5,5	
6,0														6,0	
7,0														7,0	
8,0	16,5	18,0	21,5	26,0	30,0	32,5								8,0	
9,0	15,0	16,5	20,0	24,0	28,0	30,0								9,0	
10,0	14,0	15,0	18,5	22,0	26,0	27,5		14,0	16,5	19,5	23,0	25,0		10,0	
11,0	12,9	14,0	17,0	20,3	23,5	25,0		12,8	15,3	18,0	21,3	23,0		11,0	
12,0	12,0	12,9	15,8	18,8	21,8	21,3		11,9	14,2	16,8	19,8	21,0		12,0	
14,0	10,4	11,0	13,8	16,3	16,5	16,0		10,3	12,3	14,6	16,8	16,0		14,0	
16,0	9,2	9,8	12,2	13,5	12,8	12,3		9,0	10,9	13,0	13,0	12,3		16,0	
18,0	8,2	8,6	10,8	10,8	10,1	9,7		8,0	9,6	11,0	10,2	9,6		18,0	
20,0	7,3	7,7	9,2	8,7	8,0	7,6		7,1	8,6	9,0	8,2	7,5		20,0	
22,0	6,6	6,9	7,5	7,1	6,5	6,1		6,4	7,7	7,3	6,7	6,0		22,0	
24,0	6,0	6,2	6,2	5,8	5,2	4,9		5,7	6,5	6,1	5,4	4,8		24,0	
26,0	5,5	5,6	5,2	4,8	4,2	3,9		5,2	5,5	5,1	4,4	3,8		26,0	
28,0	5,0	4,8	4,3	3,9	3,3	3,0		4,7	4,7	4,3	3,4	3,0		28,0	
30,0	4,5	4,1	3,6	3,2	2,6	2,3		4,3	3,9	3,5	2,8	2,2		30,0	
32,0	3,9	3,5	3,0	2,6	2,0	1,7		3,8	3,3	2,9	2,2	1,6		32,0	
34,0	3,4	3,0	2,5	2,1	1,5	1,1		3,3	2,8	2,3	1,6	1,1		34,0	
36,0														36,0	
38,0														38,0	
40,0														40,0	
Passagem	6							5						Passagem	
Gancho	60t												Gancho		
Modo telescópico	I	1	1	1	1	2	3		1	1	1	2	3	I	Modo telescópico
	II	1	1	2	3	3	2		1	2	3	3	3	II	
	III	2	3	3	3	2	2		3	3	3	3	2	III	
	IV	3	3	3	2	2	2		3	3	3	2	2	IV	
	V	3	3	2	2	2	2		3	3	2	2	2	V	
	VI	3	2	2	2	2	2		3	2	2	2	2	VI	

Descrição do Guindaste

Tabela 1-29 Tabela de capacidade de elevação (apenas com lança principal)

Unidade: tonelada

Estabilizadores totalmente estendidos para 8m, contrapeso de 11t, sobre a área de trabalho lateral ou traseira															
RAIO DE TRABALHO (m)	Comprimento de lança (m)												RAIO DE TRABALHO (m)		
	51,0	51,0	51,0	51,0 ★	55,2	55,2	55,2 ★		59,4	59,4 ★	63,6 ★	70,0 ★			
3,0														3,0	
3,5														3,5	
4,0														4,0	
4,5														4,5	
5,0														5,0	
5,5														5,5	
6,0														6,0	
7,0														7,0	
8,0														8,0	
9,0														9,0	
10,0														10,0	
11,0	13,5	15,5	18,0	20,0										11,0	
12,0	13,0	14,5	17,0	19,5	13,0	14,0	15,5							12,0	
14,0	11,3	13,0	15,5	16,0	11,5	13,0	14,5		11,0	12,0				14,0	
16,0	10,0	11,5	13,2	12,5	10,5	12,0	12,8		10,5	11,5	9,5			16,0	
18,0	9,0	10,4	10,5	9,8	9,5	10,8	10,2		9,6	10,6	9,2	7,0		18,0	
20,0	8,0	9,3	8,5	7,8	8,5	8,8	8,2		9,0	8,6	8,8	7,0		20,0	
22,0	7,2	7,8	7,0	6,3	7,8	7,2	6,6		7,6	6,9	7,2	6,8		22,0	
24,0	6,5	6,5	5,7	5,0	6,8	6,0	5,3		6,3	5,6	6,1	6,2		24,0	
26,0	6,0	5,5	4,7	4,0	5,8	5,0	4,3		5,4	4,7	5,1	5,2		26,0	
28,0	5,1	4,6	3,8	3,1	4,9	4,1	3,4		4,5	3,8	4,2	4,3		28,0	
30,0	4,3	3,8	3,0	2,4	4,2	3,4	2,7		3,7	3,0	3,4	3,5		30,0	
32,0	3,7	3,2	2,4	1,8	3,5	2,7	2,0		3,1	2,4	2,7	2,8		32,0	
34,0	3,1	2,6	1,8	1,2	3,0	2,2	1,5		2,5	1,8	2,1	2,2		34,0	
36,0					2,5	1,7	1,0		2,1	1,4	1,7	1,8		36,0	
38,0									1,7	0,9	1,3	1,4		38,0	
40,0											0,9	1,0		40,0	
Passagem	4				3					3		3	3	Passagem	
Gancho	60t												Gancho		
Modo telescópico	I	1	1	2	3	1	2	3		2	3	3	4	I	Modo telescópico
	II	2	3	3	3	3	3	3		3	3	3	4	II	
	III	3	3	3	3	3	3	3		3	3	3	4	III	
	IV	3	3	3	2	3	3	3		3	3	3	4	IV	
	V	3	3	2	2	3	3	2		3	3	3	4	V	
	VI	3	2	2	2	3	2	2		3	2	3	4	VI	

Tabela 1-30 Tabela de capacidade de elevação (apenas com lança principal)

Unidade: tonelada

Estabilizadores totalmente estendidos para 8m, contrapeso de 3t, sobre a área de trabalho lateral ou traseira														
RAIO DE TRABALHO (m)	Comprimento de lança (m)												RAIO DE TRABALHO (m)	
	13,2 ★	17,4	17,4	17,4	17,4	17,4 ★	21,6	21,6	21,6	21,6	21,6	21,6		
3,0	100,0	40,5	66,0	72,0	72,0	72,0	29,5	44,0	65,0	68,0	68,0	68,0	3,0	
3,5	86,0	38,0	61,0	72,0	72,0	72,0	28,0	42,0	60,0	66,0	67,0	67,0	3,5	
4,0	78,0	36,0	56,5	71,0	71,0	71,0	26,0	40,0	55,0	65,0	66,0	66,0	4,0	
4,5	66,0	34,5	52,5	65,0	65,0	65,0	24,0	38,0	52,0	62,5	63,0	63,0	4,5	
5,0	58,0	33,0	49,0	62,0	62,0	62,0	23,0	36,0	49,0	60,0	60,0	60,0	5,0	
5,5	53,0	31,5	46,0	58,0	58,0	58,0	22,0	34,0	46,0	54,0	55,0	55,0	5,5	
6,0	49,0	30,0	43,0	50,0	50,0	50,0	21,0	31,5	43,0	51,0	51,0	49,0	6,0	
7,0	39,0	27,5	38,5	41,0	40,0	39,0	19,0	29,0	39,0	41,0	40,0	38,0	7,0	
8,0	29,0	25,5	32,5	32,0	31,0	30,0	17,0	26,5	33,0	34,0	33,0	31,0	8,0	
9,0	22,5	24,0	27,0	26,5	26,0	25,0	16,0	24,5	28,0	27,0	26,0	24,5	9,0	
10,0		22,5	22,0	21,5	21,0	20,0	15,0	22,5	23,0	22,0	21,0	19,5	10,0	
11,0		18,5	18,0	17,5	17,0	16,0	13,9	20,0	19,0	18,0	17,0	15,5	11,0	
12,0		15,5	15,0	14,5	14,0	13,0	13,0	16,5	15,5	14,5	13,5	12,0	12,0	
14,0								11,5	12,5	11,8	11,0	10,0	8,5	14,0
16,0								9,8	9,5	8,8	8,0	7,2	5,7	16,0
18,0														18,0
20,0														20,0
22,0														22,0
24,0														24,0
26,0														26,0
28,0														28,0
30,0														30,0
32,0														32,0
Passagem	12	12					12					Passagem		
Gancho	60t													Gancho
Modo telescópico	I	1	1	1	1	1	1	1	1	1	1	1	2	Modo telescópico
	II	1	1	1	1	1	2	1	1	1	1	2	2	
	III	1	1	1	1	2	1	1	1	1	2	2	1	
	IV	1	1	1	2	1	1	1	1	2	2	1	1	
	V	1	1	2	1	1	1	1	2	2	1	1	1	
	VI	1	2	1	1	1	1	3	2	1	1	1	1	

Tabela 1-31 Tabela de capacidade de elevação (apenas com lança principal)

Unidade: tonelada

Estabilizadores totalmente estendidos para 8m, contrapeso de 3t, sobre a área de trabalho lateral ou traseira														
RAIO DE TRABALHO (m)	Comprimento de lança (m)												RAIO DE TRABALHO (m)	
	25,8	25,8	25,8	25,8	25,8	25,8	30,0	30,0	30,0	30,0	30,0	30,0		30,0 ★
3,0														3,0
3,5														3,5
4,0	25,0	25,0	43,0	60,0	60,0	60,0								4,0
4,5	23,5	23,5	41,0	56,0	60,0	60,0								4,5
5,0	22,0	22,0	39,5	53,0	60,0	60,0	19,0	24,0	26,0	42,0	53,0	53,0		5,0
5,5	21,0	21,0	38,0	50,0	55,0	55,0	18,5	23,0	24,5	40,5	51,5	51,5		5,5
6,0	20,0	20,0	36,0	47,0	49,0	49,0	17,5	22,0	23,0	39,5	47,0	47,0		6,0
7,0	18,0	18,0	33,0	40,0	41,0	39,0	15,8	20,0	21,0	36,0	40,0	40,0		7,0
8,0	16,5	16,5	30,0	34,0	33,0	31,0	14,3	18,5	19,0	32,0	34,0	32,0		8,0
9,0	15,0	15,0	26,0	28,0	27,0	25,5	13,0	17,0	17,5	28,0	26,0	24,0		9,0
10,0	14,0	14,0	24,5	23,5	22,5	20,5	12,0	15,5	16,0	24,5	22,5	20,5		10,0
11,0	13,0	13,0	20,5	19,5	18,5	16,5	11,0	14,5	15,0	20,5	19,5	17,5		11,0
12,0	12,0	12,0	17,0	16,0	15,0	13,5	10,3	13,5	14,0	17,0	16,0	14,0		12,0
14,0	10,5	10,5	12,5	11,5	10,5	9,5	9,0	11,9	12,0	13,0	12,0	10,2		14,0
16,0	9,4	9,3	9,9	9,1	8,1	6,6	8,0	10,5	10,2	10,0	9,0	7,2		16,0
18,0	8,3	8,1	7,7	7,0	6,0	4,5	7,1	8,3	8,0	7,8	6,8	5,3		18,0
20,0	6,7	6,5	6,1	5,4	4,4	3,0	6,4	6,7	6,4	6,2	5,2	3,7		20,0
22,0							5,8	5,4	5,1	4,9	4,0	2,5		22,0
24,0							4,8	4,4	4,1	3,9	3,0	1,6		24,0
26,0														26,0
28,0														28,0
30,0														30,0
32,0														32,0
Passagem	11						9						Passagem	
Gancho	60t												Gancho	
Modo telescópico	I	1	1	1	1	1	2	1	1	1	1	1	2	I
	II	1	1	1	1	2	2	1	1	1	1	2	2	II
	III	1	1	1	2	2	2	1	1	1	2	2	2	III
	IV	1	1	2	2	2	1	1	2	3	2	2	2	IV
	V	2	3	2	2	1	1	3	3	2	2	2	1	V
	VI	3	2	2	1	1	1	3	2	2	2	1	1	VI
Modo telescópico														

Tabela 1-32 Tabela de capacidade de elevação (apenas com lança principal)

Unidade: tonelada

Estabilizadores totalmente estendidos para 8m, contrapeso de 3t, sobre a área de trabalho lateral ou traseira														
RAIO DE TRABALHO (m)	Comprimento de lança (m)												RAIO DE TRABALHO (m)	
	34,2	34,2	34,2	34,2	34,2	34,2 ★	38,4	38,4	38,4	38,4	38,4	38,4		38,4 ★
3,0														3,0
3,5														3,5
4,0														4,0
4,5														4,5
5,0														5,0
5,5														5,5
6,0	19,0	21,5	25,5	26,0	43,0	46,0								6,0
7,0	17,0	19,0	23,0	23,5	39,0	37,0	17,0	20,0	21,5	26,0	30,5	40,0		7,0
8,0	15,5	17,5	21,0	21,5	35,0	33,0	15,5	18,5	19,5	24,0	28,0	33,0		8,0
9,0	14,5	16,0	19,5	19,5	28,0	26,0	14,0	17,0	18,0	22,0	25,5	27,0		9,0
10,0	13,3	14,5	18,0	18,0	23,5	21,5	13,0	15,7	16,5	20,3	23,0	23,0		10,0
11,0	12,3	13,5	16,5	16,5	20,5	18,5	12,0	14,5	15,2	18,8	20,3	19,7		11,0
12,0	11,5	12,5	15,5	15,5	17,0	15,5	11,0	13,5	14,0	17,0	17,0	16,5		12,0
14,0	10,1	10,8	13,0	12,5	12,0	11,0	9,5	11,7	12,2	12,7	12,3	11,9		14,0
16,0	8,9	9,6	10,3	10,0	9,7	8,2	8,5	10,4	10,2	9,7	9,3	8,9		16,0
18,0	8,0	8,5	8,1	7,9	7,5	6,0	7,5	8,4	8,0	7,5	7,1	6,7		18,0
20,0	7,0	6,8	6,4	6,2	5,9	4,5	6,7	6,9	6,5	6,0	5,6	5,2		20,0
22,0	6,0	5,6	5,2	5,0	4,7	3,3	6,0	5,6	5,2	4,7	4,5	4,1		22,0
24,0	5,0	4,6	4,2	4,0	3,7	2,3	5,1	4,6	4,2	3,7	3,5	3,1		24,0
26,0	4,1	3,7	3,3	3,1	2,9	1,5	4,2	3,7	3,3	2,9	2,7	2,3		26,0
28,0	3,4	3,0	2,6	2,4	2,2	0,9	3,5	3,0	2,6	2,2	2,0	1,6		28,0
30,0							2,9	2,4	2,0	1,6	1,4	1,0		30,0
32,0														32,0
Passagem	8						7						Passagem	
Gancho	60t												Gancho	
Modo telescópico	I	1	1	1	1	1	2	1	1	1	1	1	2	I
	II	1	1	1	1	2	2	1	1	1	2	3	2	II
	III	1	1	2	3	2	2	1	2	3	3	2	2	III
	IV	2	3	3	2	2	2	3	3	3	2	2	2	IV
	V	3	3	2	2	2	2	3	3	2	2	2	2	V
	VI	3	2	2	2	2	1	3	2	2	2	2	2	VI

Tabela 1-33 Tabela de capacidade de elevação (apenas com lança principal)

Unidade: tonelada

Estabilizadores totalmente estendidos para 8m, contrapeso de 3t, sobre a área de trabalho lateral ou traseira															
RAIO DE TRABALHO (m)	Comprimento de lança (m)												RAIO DE TRABALHO (m)		
	42,6	42,6	42,6	42,6	42,6	42,6 ★		46,8	46,8	46,8	46,8	46,8 ★			
3,0														3,0	
3,5														3,5	
4,0														4,0	
4,5														4,5	
5,0														5,0	
5,5														5,5	
6,0														6,0	
7,0														7,0	
8,0	16,5	18,0	21,5	26,0	29,0	30,0								8,0	
9,0	15,0	16,5	20,0	24,0	26,0	26,0								9,0	
10,0	14,0	15,0	18,5	22,0	22,0	21,0		14,0	16,5	19,5	21,0	20,0		10,0	
11,0	12,9	14,0	17,0	19,8	19,0	18,0		12,8	15,3	18,0	18,0	17,0		11,0	
12,0	12,0	12,9	15,8	17,0	16,3	15,3		11,9	14,2	16,2	16,0	15,4		12,0	
14,0	10,4	11,0	13,1	12,6	11,9	11,5		10,3	12,3	13,0	12,0	11,4		14,0	
16,0	9,2	9,8	10,1	9,6	8,9	8,5		9,0	10,4	9,9	8,9	8,3		16,0	
18,0	8,2	8,5	7,9	7,4	6,7	6,3		8,0	8,3	7,8	6,8	6,2		18,0	
20,0	7,3	6,8	6,2	5,8	5,1	4,7		7,1	6,6	6,1	5,3	4,7		20,0	
22,0	6,1	5,6	5,0	4,6	3,9	3,5		5,9	5,3	4,8	4,0	3,5		22,0	
24,0	5,0	4,6	4,0	3,5	2,9	2,5		4,9	4,3	3,8	3,0	2,5		24,0	
26,0	4,1	3,7	3,1	2,7	2,1	1,7		4,1	3,5	3,0	2,2	1,7		26,0	
28,0	3,4	3,0	2,4	2,0	1,4	1,1		3,4	2,8	2,3	1,5	1,0		28,0	
30,0														30,0	
32,0														32,0	
Passagem	6							5						Passagem	
Gancho	60t												Gancho		
Modo telescópico	I	1	1	1	1	2	3		1	1	1	2	3	I	Modo telescópico
	II	1	1	2	3	3	2		1	2	3	3	3	II	
	III	2	3	3	3	2	2		3	3	3	3	2	III	
	IV	3	3	3	2	2	2		3	3	3	2	2	IV	
	V	3	3	2	2	2	2		3	3	2	2	2	V	
	VI	3	2	2	2	2	2		3	2	2	2	2	VI	

Tabela 1-34 Tabela de capacidade de elevação (apenas com lança principal)

Unidade: tonelada

Estabilizadores totalmente estendidos para 8m, contrapeso de 3t, sobre a área de trabalho lateral ou traseira															
RAIO DE TRABALHO (m)	Comprimento de lança (m)												RAIO DE TRABALHO (m)		
	51,0	51,0	51,0	51,0 ★	55,2	55,2	55,2 ★		59,4	59,4 ★	63,6 ★	70,0 ★			
3,0														3,0	
3,5														3,5	
4,0														4,0	
4,5														4,5	
5,0														5,0	
5,5														5,5	
6,0														6,0	
7,0														7,0	
8,0														8,0	
9,0														9,0	
10,0														10,0	
11,0	13,5	15,5	17,0	17,5										11,0	
12,0	13,0	14,5	16,0	15,0	13,0	14,0	15,0							12,0	
14,0	11,3	12,0	12,0	11,0	11,5	11,5	10,5		11,0	11,5				14,0	
16,0	10,0	10,3	9,3	8,6	10,5	9,2	8,2		9,9	9,1	9,0			16,0	
18,0	8,8	8,2	7,2	6,5	8,5	7,5	6,5		8,0	7,2	7,6	6,5		18,0	
20,0	7,0	6,4	5,5	4,8	6,8	6,0	5,2		6,4	5,6	6,0	6,1		20,0	
22,0	5,7	5,1	4,3	3,6	5,5	4,7	3,9		5,1	4,3	4,8	4,9		22,0	
24,0	4,7	4,1	3,3	2,6	4,4	3,6	2,9		4,1	3,3	3,7	3,8		24,0	
26,0	3,8	3,3	2,5	1,8	3,6	2,8	2,1		3,2	2,4	2,9	3,0		26,0	
28,0	3,1	2,6	1,8	1,1	2,9	2,1	1,4		2,5	1,7	2,2	2,3		28,0	
30,0					2,4	1,6	0,9		1,9	1,1	1,6	1,7		30,0	
32,0											1,1	1,2		32,0	
Passagem	4				3					3		3	3	Passagem	
Gancho	60t												Gancho		
Modo telescópico	I	1	1	2	3	1	2	3		2	3	3	4	I	Modo telescópico
	II	2	3	3	3	3	3	3		3	3	3	4	II	
	III	3	3	3	3	3	3	3		3	3	3	4	III	
	IV	3	3	3	2	3	3	3		3	3	3	4	IV	
	V	3	3	2	2	3	3	2		3	3	3	4	V	
	VI	3	2	2	2	3	2	2		3	2	3	4	VI	

Tabela 1-35 Tabela de capacidade de elevação (apenas com lança principal)

Unidade: tonelada

Estabilizadores totalmente estendidos para 8m, contrapeso de 34t, sobre a área de trabalho lateral ou traseira															
RAIO DE TRABALHO (m)	Comprimento da lança da ponta: 3m, deslocamento: 30°												RAIO DE TRABALHO (m)		
	13,2 ★	17,4	17,4	17,4	17,4	17,4 ★	21,6	21,6	21,6	21,6	21,6	21,6		21,6 ★	
3,0	18,0													3,0	
3,5	16,0	16,0	16,0	16,0	16,0	16,0								3,5	
4,0	16,0	16,0	16,0	16,0	16,0	16,0								4,0	
4,5	16,0	16,0	16,0	16,0	16,0	16,0	16,0	16,0	16,0	16,0	16,0	16,0	16,0	4,5	
5,0	16,0	16,0	16,0	16,0	16,0	16,0	16,0	16,0	16,0	16,0	16,0	16,0	16,0	5,0	
5,5	16,0	16,0	16,0	16,0	16,0	16,0	16,0	16,0	16,0	16,0	16,0	16,0	16,0	5,5	
6,0	16,0	16,0	16,0	16,0	16,0	16,0	16,0	16,0	16,0	16,0	16,0	16,0	16,0	6,0	
7,0	16,0	16,0	16,0	16,0	16,0	16,0	16,0	16,0	16,0	16,0	16,0	16,0	16,0	7,0	
8,0	15,5	16,0	16,0	16,0	16,0	16,0	16,0	16,0	16,0	16,0	16,0	16,0	16,0	8,0	
9,0	15,0	16,0	16,0	16,0	16,0	16,0	15,0	16,0	16,0	16,0	16,0	16,0	16,0	9,0	
10,0	14,5	15,5	15,5	15,5	15,5	15,5	14,0	16,0	16,0	16,0	16,0	16,0	16,0	10,0	
11,0	14,0	15,0	15,0	15,0	15,0	15,0	13,0	16,0	16,0	16,0	16,0	16,0	16,0	11,0	
12,0	13,5	14,5	14,5	14,5	14,5	14,5	12,0	16,0	16,0	16,0	16,0	16,0	16,0	12,0	
14,0		14,0	14,0	14,0	14,0	14,0	11,0	14,5	15,5	15,5	15,5	15,5	15,5	14,0	
16,0		13,5	13,5	13,5	13,5	13,5	10,0	13,0	15,0	15,0	15,0	15,0	15,0	16,0	
18,0							9,0	12,0	14,0	14,0	14,0	14,0	14,0	18,0	
20,0							8,0	11,0	13,0	13,0	13,0	13,0	13,0	20,0	
22,0														22,0	
24,0														24,0	
26,0														26,0	
28,0														28,0	
30,0														30,0	
32,0														32,0	
34,0														34,0	
36,0														36,0	
38,0														38,0	
40,0														40,0	
42,0														42,0	
44,0														44,0	
46,0														46,0	
48,0														48,0	
50,0														50,0	
Passagem	3													Passagem	
Gancho	18t													Gancho	
Modo telescópico	I	1	1	1	1	1	1	1	1	1	1	1	2	I	Modo telescópico
	II	1	1	1	1	1	2	1	1	1	1	2	2	II	
	III	1	1	1	1	2	1	1	1	1	2	2	1	III	
	IV	1	1	1	2	1	1	1	1	2	2	1	1	IV	
	V	1	1	2	1	1	1	1	2	2	1	1	1	V	
	VI	1	2	1	1	1	1	3	2	1	1	1	1	VI	

Tabela 1-36 Tabela de capacidade de elevação (apenas com lança principal)

Unidade: tonelada

Estabilizadores totalmente estendidos para 8m, contrapeso de 34t, sobre a área de trabalho lateral ou traseira															
RAIO DE TRABALHO (m)	Comprimento da lança da ponta: 3m, deslocamento: 30°												RAIO DE TRABALHO (m)		
	25,8	25,8	25,8	25,8	25,8	25,8★	30,0	30,0	30,0	30,0	30,0	30,0★			
3,0														3,0	
3,5														3,5	
4,0														4,0	
4,5														4,5	
5,0														5,0	
5,5	16,0	16,0	16,0	16,0	16,0	16,0								5,5	
6,0	15,0	15,0	16,0	16,0	16,0	16,0								6,0	
7,0	14,0	14,0	16,0	16,0	16,0	16,0	13,5	16,0	16,0	16,0	16,0	16,0	16,0	7,0	
8,0	13,0	13,0	16,0	16,0	16,0	16,0	12,2	15,0	16,0	16,0	16,0	16,0	16,0	8,0	
9,0	12,0	12,0	16,0	16,0	16,0	16,0	11,2	14,0	15,0	16,0	16,0	16,0	16,0	9,0	
10,0	11,0	11,0	16,0	16,0	16,0	16,0	10,2	13,0	14,0	16,0	16,0	16,0	16,0	10,0	
11,0	10,5	10,5	16,0	16,0	16,0	16,0	9,5	12,0	13,0	16,0	16,0	16,0	16,0	11,0	
12,0	10,0	10,0	16,0	16,0	16,0	16,0	9,0	11,0	12,0	16,0	16,0	16,0	16,0	12,0	
14,0	9,0	9,0	16,0	16,0	16,0	16,0	8,0	10,0	10,5	16,0	16,0	16,0	16,0	14,0	
16,0	8,0	8,0	15,0	15,5	15,5	16,0	7,0	9,0	9,5	16,0	16,0	16,0	16,0	16,0	
18,0	7,0	7,0	13,5	15,0	15,0	15,5	6,0	8,0	8,5	14,5	16,0	15,0	18,0	18,0	
20,0	6,5	6,5	12,5	14,5	14,0	13,0	5,5	7,3	7,5	13,5	14,0	13,0	20,0	20,0	
22,0	6,0	6,0	11,5	12,5	12,0	10,5	5,0	6,6	6,8	12,5	12,0	11,5	22,0	22,0	
24,0							4,5	6,0	6,2	11,8	11,0	10,5	24,0	24,0	
26,0							4,2	5,6	5,8	10,0	9,5	9,0	26,0	26,0	
28,0													28,0	28,0	
30,0													30,0	30,0	
32,0													32,0	32,0	
34,0													34,0	34,0	
36,0													36,0	36,0	
38,0													38,0	38,0	
40,0													40,0	40,0	
42,0													42,0	42,0	
44,0													44,0	44,0	
46,0													46,0	46,0	
48,0													48,0	48,0	
50,0													50,0	50,0	
Passagem	3												Passagem		
Gancho	18t												Gancho		
Modo telescópico	I	1	1	1	1	1	2	1	1	1	1	1	2	I	Modo telescópico
	II	1	1	1	1	2	2	1	1	1	1	2	2	II	
	III	1	1	1	2	2	2	1	1	1	2	2	2	III	
	IV	1	1	2	2	2	1	1	2	3	2	2	2	IV	
	V	2	3	2	2	1	1	3	3	2	2	2	1	V	
	VI	3	2	2	1	1	1	3	2	2	2	1	1	VI	

Descrição do Guindaste

Tabela 1-37 Tabela de capacidade de elevação (apenas com lança principal)

Unidade: tonelada

Estabilizadores totalmente estendidos para 8m, contrapeso de 34t, sobre a área de trabalho lateral ou traseira														
RAIO DE TRABALHO (m)	Comprimento da lança da ponta: 3m, deslocamento: 30°												RAIO DE TRABALHO (m)	
	34,2	34,2	34,2	34,2	34,2	34,2 ★	38,4	38,4	38,4	38,4	38,4	38,4 ★		
3,0														3,0
3,5														3,5
4,0														4,0
4,5														4,5
5,0														5,0
5,5														5,5
6,0														6,0
7,0														7,0
8,0	12,5	14,0	16,0	16,0	16,0	16,0								8,0
9,0	11,5	13,0	16,0	16,0	16,0	16,0	12,0	14,0	16,0	16,0	16,0	16,0	16,0	9,0
10,0	10,5	12,0	15,0	15,0	16,0	16,0	11,0	13,0	15,0	16,0	16,0	16,0	16,0	10,0
11,0	10,0	11,0	14,0	14,0	16,0	16,0	10,0	12,0	14,0	16,0	16,0	16,0	16,0	11,0
12,0	9,5	10,0	13,0	13,0	16,0	16,0	9,5	11,5	13,0	15,5	16,0	16,0	16,0	12,0
14,0	8,5	9,0	12,0	12,0	15,0	16,0	8,1	10,0	11,0	14,0	15,0	15,5	14,0	14,0
16,0	7,5	8,0	10,5	10,5	14,0	15,0	7,2	9,0	10,0	12,5	14,5	15,0	16,0	16,0
18,0	6,5	7,0	9,5	9,5	13,5	14,5	6,3	8,0	8,8	11,0	13,0	14,5	18,0	18,0
20,0	6,0	6,5	8,5	8,5	13,0	14,0	5,7	7,0	7,8	10,0	11,8	14,0	20,0	20,0
22,0	5,5	5,8	7,7	7,7	12,5	12,0	5,1	6,5	7,0	9,0	10,5	12,5	22,0	22,0
24,0	5,0	5,3	7,0	7,0	11,5	10,5	4,6	6,0	6,4	8,0	9,5	11,2	24,0	24,0
26,0	4,5	4,8	6,5	6,5	10,5	9,5	4,2	5,5	5,8	7,5	8,8	10,2	26,0	26,0
28,0	4,2	4,5	6,0	6,0	9,0	8,0	3,8	5,1	5,3	7,0	8,0	8,8	28,0	28,0
30,0	3,9	4,2	5,5	5,5	8,0	7,0	3,5	4,7	4,8	6,5	7,3	7,7	30,0	30,0
32,0							3,2	4,3	4,4	6,0	6,7	6,7	32,0	32,0
34,0							3,0	3,9	4,1	5,5	6,2	5,9	34,0	34,0
36,0													36,0	36,0
38,0													38,0	38,0
40,0													40,0	40,0
42,0													42,0	42,0
44,0													44,0	44,0
46,0													46,0	46,0
48,0													48,0	48,0
50,0													50,0	50,0
Passagem	3												Passagem	
Gancho	18t												Gancho	
Modo telescópico	I	1	1	1	1	1	2	1	1	1	1	1	2	I
	II	1	1	1	1	2	2	1	1	1	2	3	2	II
	III	1	1	2	3	2	2	1	2	3	3	2	2	III
	IV	2	3	3	2	2	2	3	3	3	2	2	2	IV
	V	3	3	2	2	2	2	3	3	2	2	2	2	V
	VI	3	2	2	2	2	1	3	2	2	2	2	2	VI

Tabela 1-38 Tabela de capacidade de elevação (apenas com lança principal)

Unidade: tonelada

Estabilizadores totalmente estendidos para 8m, contrapeso de 34t, sobre a área de trabalho lateral ou traseira															
RAIO DE TRABALHO (m)	Comprimento da lança da ponta: 3m, deslocamento: 30°												RAIO DE TRABALHO (m)		
	42,6	42,6	42,6	42,6	42,6	42,6★		46,8	46,8	46,8	46,8	46,8★			
3,0														3,0	
3,5														3,5	
4,0														4,0	
4,5														4,5	
5,0														5,0	
5,5														5,5	
6,0														6,0	
7,0														7,0	
8,0														8,0	
9,0														9,0	
10,0														10,0	
11,0	10,5	12,0	14,0	16,0	16,0	16,0		10,5	12,0	14,0	16,0	16,0	16,0	11,0	
12,0	10,0	11,0	13,0	15,0	15,0	15,0		9,5	11,0	13,0	16,0	16,0	16,0	12,0	
14,0	9,0	9,5	11,5	13,5	14,5	14,5		9,0	10,5	12,5	15,0	15,0	15,0	14,0	
16,0	8,0	8,5	10,0	12,5	14,0	14,0		8,0	9,5	11,5	13,5	14,5	14,5	16,0	
18,0	7,1	7,7	9,1	11,5	13,0	13,5		7,0	8,5	10,0	12,0	13,0	13,0	18,0	
20,0	6,4	7,1	8,4	10,5	12,5	13,0		6,5	7,8	9,0	11,0	12,0	12,0	20,0	
22,0	5,8	6,3	7,6	9,5	11,0	11,5		5,7	7,0	8,5	10,0	11,0	11,0	22,0	
24,0	5,2	5,7	7,0	8,5	10,0	10,5		5,2	6,4	7,4	9,0	9,8	9,8	24,0	
26,0	4,8	5,2	6,4	7,7	9,5	9,5		4,8	5,8	6,8	8,3	9,0	9,0	26,0	
28,0	4,4	4,7	5,9	7,0	8,5	8,5		4,4	5,3	6,3	7,6	8,2	8,2	28,0	
30,0	4,1	4,3	5,3	6,5	7,5	7,2		4,0	4,8	5,8	7,0	7,2	7,2	30,0	
32,0	3,8	3,8	4,8	6,0	6,5	6,2		3,6	4,4	5,3	6,3	6,3	6,3	32,0	
34,0	3,5	3,5	4,5	5,5	5,8	5,5		3,3	4,0	4,8	5,8	5,5	5,5	34,0	
36,0	3,2	3,2	4,2	5,0	5,0	4,7		3,0	3,7	4,4	5,2	4,7	4,7	36,0	
38,0	3,0	3,0	3,9	4,6	4,4	4,1		2,7	3,4	4,0	4,5	4,0	4,0	38,0	
40,0								2,5	3,1	3,7	3,9	3,4	3,4	40,0	
42,0								2,3	2,9	3,4	3,4	2,9	2,9	42,0	
44,0														44,0	
46,0														46,0	
48,0														48,0	
50,0														50,0	
Passagem Gancho	3												Passagem Gancho		
	18t														
Modo telescópico	I	1	1	1	1	2	3		1	1	1	2	3	I	Modo telescópico
	II	1	1	2	3	3	2		1	2	3	3	3	II	
	III	2	3	3	3	2	2		3	3	3	3	2	III	
	IV	3	3	3	2	2	2		3	3	3	2	2	IV	
	V	3	3	2	2	2	2		3	3	2	2	2	V	
	VI	3	2	2	2	2	2		3	2	2	2	2	VI	

Tabela 1-39 Tabela de capacidade de elevação (apenas com lança principal)

Unidade: tonelada

Estabilizadores totalmente estendidos para 8m, contrapeso de 34t, sobre a área de trabalho lateral ou traseira															
RAIO DE TRABALHO (m)	Comprimento da lança da ponta: 3m, deslocamento: 30°												RAIO DE TRABALHO (m)		
	51,0	51,0	51,0	51,0★	55,2	55,2	55,2★		59,4	59,4★	63,6★	70,0★			
4,0														4,0	
4,5														4,5	
5,0														5,0	
5,5														5,5	
6,0														6,0	
7,0														7,0	
8,0														8,0	
9,0														9,0	
10,0														10,0	
11,0														11,0	
12,0														12,0	
14,0	9,5	11,0	12,5	14,0	9,5	11,0	12,0							14,0	
16,0	8,5	10,0	11,5	13,0	8,7	10,0	11,0		9,0	10,0				16,0	
18,0	7,5	9,0	10,5	12,0	8,1	9,3	10,0		8,5	9,5	7,8			18,0	
20,0	7,0	8,2	9,5	11,0	7,5	8,6	9,4		8,0	8,8	7,5	6,5		20,0	
22,0	6,5	7,5	8,7	10,0	6,9	8,0	8,8		7,5	8,2	7,2	6,2		22,0	
24,0	5,7	6,9	8,0	9,0	6,3	7,4	8,2		6,8	7,5	6,9	6,0		24,0	
26,0	5,2	6,3	7,4	8,4	5,8	6,8	7,6		6,2	6,9	6,4	5,7		26,0	
28,0	4,8	5,7	6,8	7,5	5,3	6,2	7,0		5,7	6,4	5,9	5,3		28,0	
30,0	4,4	5,3	6,3	6,8	4,8	5,7	6,4		5,3	5,9	5,4	4,9		30,0	
32,0	4,1	4,8	5,8	6,3	4,4	5,3	5,8		4,9	5,4	5,0	4,5		32,0	
34,0	3,8	4,4	5,3	5,6	4,1	4,9	5,3		4,5	5,0	4,6	4,2		34,0	
36,0	3,5	4,0	4,8	4,8	3,8	4,5	4,8		4,1	4,6	4,2	3,9		36,0	
38,0	3,2	3,7	4,3	4,2	3,5	4,1	4,4		3,8	4,2	3,9	3,6		38,0	
40,0	2,9	3,4	3,9	3,6	3,2	3,7	3,8		3,5	3,9	3,6	3,3		40,0	
42,0	2,6	3,1	3,5	3,0	2,9	3,4	3,3		3,2	3,5	3,3	3,0		42,0	
44,0	2,4	2,8	3,1	2,6	2,7	3,1	2,8		3,0	3,1	3,1	2,7		44,0	
46,0	2,2	2,5	2,7	2,1	2,4	2,9	2,3		2,8	2,7	2,9	2,4		46,0	
48,0					2,2	2,6	1,9		2,6	2,3	2,6	2,2		48,0	
50,0					2,0	2,2	1,5		2,4	1,9	2,2	2,0		50,0	
52,0									2,2	1,6	1,8	1,8		52,0	
54,0									1,9	1,3	1,5	1,6		54,0	
56,0											1,2	1,4		56,0	
58,0											1,0	1,1		58,0	
Passagem Gancho	3						2						Passagem Gancho		
Modo telescópico	I	1	1	2	3	1	2	3		2	3	3	4	I	Modo telescópico
	II	2	3	3	3	3	3	3		3	3	3	4	II	
	III	3	3	3	3	3	3	3		3	3	3	4	III	
	IV	3	3	3	2	3	3	3		3	3	3	4	IV	
	V	3	3	2	2	3	3	2		3	3	3	4	V	
	VI	3	2	2	2	3	2	2		3	2	3	4	VI	

Tabela 1-40 Tabela de capacidade de elevação (apenas com lança principal)

Unidade: tonelada

Estabilizadores totalmente estendidos para 8m, contrapeso de 23t, sobre a área de trabalho lateral ou traseira														
RAIO DE TRABALHO (m)	Comprimento da lança da ponta: 3m, deslocamento: 30°												RAIO DE TRABALHO (m)	
	13,2 ★	17,4	17,4	17,4	17,4	17,4 ★	21,6	21,6	21,6	21,6	21,6	21,6		21,6 ★
3,0	18,0													3,0
3,5	16,0	16,0	16,0	16,0	16,0	16,0								3,5
4,0	16,0	16,0	16,0	16,0	16,0	16,0								4,0
4,5	16,0	16,0	16,0	16,0	16,0	16,0	16,0	16,0	16,0	16,0	16,0	16,0	16,0	4,5
5,0	16,0	16,0	16,0	16,0	16,0	16,0	16,0	16,0	16,0	16,0	16,0	16,0	16,0	5,0
5,5	16,0	16,0	16,0	16,0	16,0	16,0	16,0	16,0	16,0	16,0	16,0	16,0	16,0	5,5
6,0	16,0	16,0	16,0	16,0	16,0	16,0	16,0	16,0	16,0	16,0	16,0	16,0	16,0	6,0
7,0	16,0	16,0	16,0	16,0	16,0	16,0	16,0	16,0	16,0	16,0	16,0	16,0	16,0	7,0
8,0	15,5	16,0	16,0	16,0	16,0	16,0	16,0	16,0	16,0	16,0	16,0	16,0	16,0	8,0
9,0	15,0	16,0	16,0	16,0	16,0	16,0	15,0	16,0	16,0	16,0	16,0	16,0	16,0	9,0
10,0	14,5	15,5	15,5	15,5	15,5	15,5	14,0	16,0	16,0	16,0	16,0	16,0	16,0	10,0
11,0	14,0	15,0	15,0	15,0	15,0	15,0	13,0	16,0	16,0	16,0	16,0	16,0	16,0	11,0
12,0	13,5	14,5	14,5	14,5	14,5	14,5	12,0	16,0	16,0	16,0	16,0	16,0	16,0	12,0
14,0		14,0	14,0	14,0	14,0	14,0	11,0	14,5	15,5	15,5	15,5	15,5	15,5	14,0
16,0		13,5	13,5	13,5	13,5	13,5	10,0	13,0	15,0	15,0	15,0	15,0	15,0	16,0
18,0							9,0	12,0	14,0	14,0	13,5	12,5	12,5	18,0
20,0							8,0	11,0	12,5	12,0	11,0	10,0	10,0	20,0
22,0														22,0
24,0														24,0
26,0														26,0
28,0														28,0
30,0														30,0
32,0														32,0
34,0														34,0
36,0														36,0
38,0														38,0
40,0														40,0
42,0														42,0
44,0														44,0
46,0														46,0
48,0														48,0
50,0														50,0
Passagem Gancho	3													Passagem Gancho
	18t													
Modo telescópico	I	1	1	1	1	1	1	1	1	1	1	1	2	I
	II	1	1	1	1	1	2	1	1	1	1	2	2	II
	III	1	1	1	1	2	1	1	1	1	2	2	1	III
	IV	1	1	1	2	1	1	1	1	2	2	1	1	IV
	V	1	1	2	1	1	1	1	2	2	1	1	1	V
	VI	1	2	1	1	1	1	3	2	1	1	1	1	VI
														Modo telescópico

Descrição do Guindaste

Tabela 1-41 Tabela de capacidade de elevação (apenas com lança principal)

Unidade: tonelada

Estabilizadores totalmente estendidos para 8m, contrapeso de 23t, sobre a área de trabalho lateral ou traseira															
RAIO DE TRABALHO (m)	Comprimento da lança da ponta: 3m, deslocamento: 30°												RAIO DE TRABALHO (m)		
	25,8	25,8	25,8	25,8	25,8	25,8★	30,0	30,0	30,0	30,0	30,0	30,0★			
3,0														3,0	
3,5														3,5	
4,0														4,0	
4,5														4,5	
5,0														5,0	
5,5	16,0	16,0	16,0	16,0	16,0	16,0								5,5	
6,0	15,0	15,0	16,0	16,0	16,0	16,0								6,0	
7,0	14,0	14,0	16,0	16,0	16,0	16,0	13,5	16,0	16,0	16,0	16,0	16,0	16,0	7,0	
8,0	13,0	13,0	16,0	16,0	16,0	16,0	12,2	15,0	16,0	16,0	16,0	16,0	16,0	8,0	
9,0	12,0	12,0	16,0	16,0	16,0	16,0	11,2	14,0	15,0	16,0	16,0	16,0	16,0	9,0	
10,0	11,0	11,0	16,0	16,0	16,0	16,0	10,2	13,0	14,0	16,0	16,0	16,0	16,0	10,0	
11,0	10,5	10,5	16,0	16,0	16,0	16,0	9,5	12,0	13,0	16,0	16,0	16,0	16,0	11,0	
12,0	10,0	10,0	16,0	16,0	16,0	16,0	9,0	11,0	12,0	16,0	16,0	16,0	16,0	12,0	
14,0	9,0	9,0	16,0	16,0	16,0	16,0	8,0	10,0	10,5	16,0	16,0	16,0	16,0	14,0	
16,0	8,0	8,0	15,0	15,5	15,5	15,0	7,0	9,0	9,5	16,0	16,0	16,0	16,0	16,0	
18,0	7,0	7,0	13,5	14,5	14,5	13,5	6,0	8,0	8,5	14,5	15,0	14,0	14,0	18,0	
20,0	6,5	6,5	12,5	12,5	12,0	11,0	5,5	7,3	7,5	13,5	12,5	11,5	11,5	20,0	
22,0	6,0	6,0	11,0	10,5	10,0	9,0	5,0	6,6	6,8	11,5	10,5	9,5	9,5	22,0	
24,0							4,5	6,0	6,2	9,8	9,0	7,8	7,8	24,0	
26,0							4,2	5,6	5,8	8,5	7,5	6,5	6,5	26,0	
28,0														28,0	
30,0														30,0	
32,0														32,0	
34,0														34,0	
36,0														36,0	
38,0														38,0	
40,0														40,0	
42,0														42,0	
44,0														44,0	
46,0														46,0	
48,0														48,0	
50,0														50,0	
Passagem	3													Passagem	
Gancho	18t													Gancho	
Modo telescópico	I	1	1	1	1	1	2	1	1	1	1	1	2	I	Modo telescópico
	II	1	1	1	1	2	2	1	1	1	1	2	2	II	
	III	1	1	1	2	2	2	1	1	1	2	2	2	III	
	IV	1	1	2	2	2	1	1	2	3	2	2	2	IV	
	V	2	3	2	2	1	1	3	3	2	2	2	1	V	
	VI	3	2	2	1	1	1	3	2	2	2	1	1	VI	

Tabela 1-42 Tabela de capacidade de elevação (apenas com lança principal)

Unidade: tonelada

Estabilizadores totalmente estendidos para 8m, contrapeso de 23t, sobre a área de trabalho lateral ou traseira														
RAIO DE TRABALHO (m)	Comprimento da lança da ponta: 3m, deslocamento: 30°												RAIO DE TRABALHO (m)	
	34,2	34,2	34,2	34,2	34,2	34,2★	38,4	38,4	38,4	38,4	38,4	38,4★		
3,0														3,0
3,5														3,5
4,0														4,0
4,5														4,5
5,0														5,0
5,5														5,5
6,0														6,0
7,0														7,0
8,0	12,5	14,0	16,0	16,0	16,0	16,0								8,0
9,0	11,5	13,0	16,0	16,0	16,0	16,0	12,0	14,0	16,0	16,0	16,0	16,0	16,0	9,0
10,0	10,5	12,0	15,0	15,0	16,0	16,0	11,0	13,0	15,0	16,0	16,0	16,0	16,0	10,0
11,0	10,0	11,0	14,0	14,0	16,0	16,0	10,0	12,0	14,0	16,0	16,0	16,0	16,0	11,0
12,0	9,5	10,0	13,0	13,0	16,0	16,0	9,5	11,5	13,0	15,5	16,0	16,0	16,0	12,0
14,0	8,5	9,0	12,0	12,0	15,0	16,0	8,1	10,0	11,0	14,0	15,0	15,5	15,5	14,0
16,0	7,5	8,0	10,5	10,5	14,0	15,0	7,2	9,0	10,0	12,5	14,5	15,0	15,0	16,0
18,0	6,5	7,0	9,5	9,5	13,5	14,5	6,3	8,0	8,8	11,0	13,0	14,5	14,5	18,0
20,0	6,0	6,5	8,5	8,5	13,0	12,0	5,7	7,0	7,8	10,0	11,8	12,5	12,5	20,0
22,0	5,5	5,8	7,7	7,7	11,0	10,0	5,1	6,5	7,0	9,0	10,5	10,5	10,5	22,0
24,0	5,0	5,3	7,0	7,0	9,5	8,5	4,6	6,0	6,4	8,0	9,2	9,0	9,0	24,0
26,0	4,5	4,8	6,5	6,5	8,0	7,0	4,2	5,5	5,8	7,5	8,0	7,8	7,8	26,0
28,0	4,2	4,5	6,0	6,0	7,0	6,0	3,8	5,1	5,3	7,0	7,0	6,5	6,5	28,0
30,0	3,9	4,2	5,5	5,5	6,0	5,0	3,5	4,7	4,8	6,0	6,0	5,6	5,6	30,0
32,0							3,2	4,3	4,4	5,3	5,2	4,8	4,8	32,0
34,0							3,0	3,9	4,1	4,6	4,5	4,1	4,1	34,0
36,0														36,0
38,0														38,0
40,0														40,0
42,0														42,0
44,0														44,0
46,0														46,0
48,0														48,0
50,0														50,0
Passagem	3												Passagem	
Gancho	18t												Gancho	
Modo telescópico	I	1	1	1	1	1	2	1	1	1	1	1	2	I
	II	1	1	1	1	2	2	1	1	1	2	3	2	II
	III	1	1	2	3	2	2	1	2	3	3	2	2	III
	IV	2	3	3	2	2	2	3	3	3	2	2	2	IV
	V	3	3	2	2	2	2	3	3	2	2	2	2	V
	VI	3	2	2	2	2	1	3	2	2	2	2	2	VI

Descrição do Guindaste

Tabela 1-43 Tabela de capacidade de elevação (apenas com lança principal)

Unidade: tonelada

Estabilizadores totalmente estendidos para 8m, contrapeso de 23t, sobre a área de trabalho lateral ou traseira															
RAIO DE TRABALHO (m)	Comprimento da lança da ponta: 3m, deslocamento: 30°												RAIO DE TRABALHO (m)		
	42,6	42,6	42,6	42,6	42,6	42,6 ★		46,8	46,8	46,8	46,8	46,8 ★			
3,0														3,0	
3,5														3,5	
4,0														4,0	
4,5														4,5	
5,0														5,0	
5,5														5,5	
6,0														6,0	
7,0														7,0	
8,0														8,0	
9,0														9,0	
10,0														10,0	
11,0	10,5	12,0	14,0	16,0	16,0	16,0		10,5	12,0	14,0	16,0	16,0	11,0		
12,0	10,0	11,0	13,0	15,0	15,0	15,0		9,5	11,0	13,0	16,0	16,0	12,0		
14,0	9,0	9,5	11,5	13,5	14,5	14,5		9,0	10,5	12,5	15,0	15,0	14,0		
16,0	8,0	8,5	10,0	12,5	14,0	14,0		8,0	9,5	11,5	13,5	14,5	16,0		
18,0	7,1	7,7	9,1	11,5	13,0	13,5		7,0	8,5	10,0	12,0	13,0	18,0		
20,0	6,4	7,1	8,4	10,5	12,5	12,0		6,5	7,8	9,0	11,0	12,0	20,0		
22,0	5,8	6,3	7,6	9,5	10,5	10,0		5,7	7,0	8,5	10,0	10,0	22,0		
24,0	5,2	5,7	7,0	8,5	9,0	8,5		5,2	6,4	7,4	9,0	8,5	24,0		
26,0	4,8	5,2	6,4	7,7	7,7	7,2		4,8	5,8	6,8	7,6	7,1	26,0		
28,0	4,4	4,7	5,9	6,9	6,5	6,0		4,4	5,3	6,3	6,5	6,0	28,0		
30,0	4,1	4,3	5,3	6,0	5,5	5,0		4,0	4,8	5,8	5,6	5,1	30,0		
32,0	3,8	3,8	4,8	5,2	4,7	4,2		3,6	4,4	5,3	4,7	4,2	32,0		
34,0	3,5	3,5	4,5	4,5	4,0	3,5		3,3	4,0	4,6	4,0	3,5	34,0		
36,0	3,2	3,2	4,0	3,8	3,3	2,9		3,0	3,7	4,0	3,4	2,9	36,0		
38,0	3,0	3,0	3,5	3,3	2,8	2,4		2,7	3,4	3,4	2,8	2,3	38,0		
40,0								2,5	3,1	2,9	2,3	1,8	40,0		
42,0								2,3	2,8	2,5	1,9	1,4	42,0		
44,0													44,0		
46,0													46,0		
48,0													48,0		
50,0													50,0		
Passagem Gancho	3 18t												Passagem Gancho		
Modo telescópico	I	1	1	1	1	2	3		1	1	1	2	3	I	Modo telescópico
	II	1	1	2	3	3	2		1	2	3	3	3	II	
	III	2	3	3	3	2	2		3	3	3	3	2	III	
	IV	3	3	3	2	2	2		3	3	3	2	2	IV	
	V	3	3	2	2	2	2		3	3	2	2	2	V	
	VI	3	2	2	2	2	2		3	2	2	2	2	VI	

Tabela 1-44 Tabela de capacidade de elevação (apenas com lança principal)

Unidade: tonelada

Estabilizadores totalmente estendidos para 8m, contrapeso de 23t, sobre a área de trabalho lateral ou traseira														
RAIO DE TRABALHO (m)	Comprimento da lança da ponta: 3m, deslocamento: 30°												RAIO DE TRABALHO (m)	
	51,0	51,0	51,0	51,0★	55,2	55,2	55,2★		59,4	59,4★	63,6★	70,0★		
4,0														
4,5														
5,0														
5,5														
6,0														
7,0														
8,0														
9,0														
10,0														
11,0														
12,0														
14,0	9,5	11,0	12,5	14,0	9,5	11,0	12,0							
16,0	8,5	10,0	11,5	13,0	8,7	10,0	11,0		9,0	10,0				
18,0	7,5	9,0	10,5	12,0	8,1	9,3	10,0		8,5	9,5	7,8			
20,0	7,0	8,2	9,5	11,0	7,5	8,6	9,4		8,0	8,8	7,5	6,5		
22,0	6,5	7,5	8,7	10,0	6,9	8,0	8,8		7,5	8,2	7,2	6,2		
24,0	5,7	6,9	8,0	8,5	6,3	7,4	8,2		6,8	7,5	6,9	6,0		
26,0	5,2	6,3	7,4	7,2	5,8	6,8	7,5		6,2	6,9	6,4	5,7		
28,0	4,8	5,7	6,7	6,2	5,3	6,2	6,4		5,7	6,4	5,9	5,3		
30,0	4,4	5,3	5,8	5,3	4,8	5,7	5,4		5,3	5,8	5,4	4,9		
32,0	4,1	4,8	5,0	4,5	4,4	5,3	4,6		4,9	5,0	5,0	4,5		
34,0	3,8	4,4	4,2	3,7	4,1	4,5	3,9		4,5	4,3	4,5	4,2		
36,0	3,5	4,0	3,6	3,1	3,8	4,0	3,3		4,1	3,6	3,8	3,9		
38,0	3,2	3,7	3,0	2,5	3,5	3,4	2,7		3,6	3,0	3,4	3,5		
40,0	2,9	3,2	2,5	2,0	3,2	2,9	2,2		3,1	2,5	2,9	3,0		
42,0	2,6	2,7	2,1	1,5	2,9	2,4	1,7		2,7	2,0	2,4	2,5		
44,0	2,4	2,3	1,7	1,1	2,6	2,0	1,3		2,3	1,6	2,0	2,1		
46,0					2,2	1,6	1,0		1,9	1,2	1,6	1,7		
48,0									1,6	0,9	1,2	1,3		
50,0											0,9	1,0		
Passagem	3						2						Passagem	
Gancho	18t												Gancho	
Modo telescópico	I	1	1	2	3	1	2	3		2	3	3	4	I
	II	2	3	3	3	3	3	3		3	3	3	4	II
	III	3	3	3	3	3	3	3		3	3	3	4	III
	IV	3	3	3	2	3	3	3		3	3	3	4	IV
	V	3	3	2	2	3	3	2		3	3	3	4	V
	VI	3	2	2	2	3	2	2		3	2	3	4	VI

Descrição do Guindaste

Tabela 1-45 Tabela de capacidade de elevação (apenas com lança principal)

Unidade: tonelada

Estabilizadores totalmente estendidos para 8m, contrapeso de 19t, sobre a área de trabalho lateral ou traseira															
RAIO DE TRABALHO (m)	Comprimento da lança da ponta: 3m, deslocamento: 30°												RAIO DE TRABALHO (m)		
	13,2 ★	17,4	17,4	17,4	17,4	17,4 ★	21,6	21,6	21,6	21,6	21,6	21,6		21,6 ★	
3,0	18,0													3,0	
3,5	16,0	16,0	16,0	16,0	16,0	16,0								3,5	
4,0	16,0	16,0	16,0	16,0	16,0	16,0								4,0	
4,5	16,0	16,0	16,0	16,0	16,0	16,0	16,0	16,0	16,0	16,0	16,0	16,0	16,0	4,5	
5,0	16,0	16,0	16,0	16,0	16,0	16,0	16,0	16,0	16,0	16,0	16,0	16,0	16,0	5,0	
5,5	16,0	16,0	16,0	16,0	16,0	16,0	16,0	16,0	16,0	16,0	16,0	16,0	16,0	5,5	
6,0	16,0	16,0	16,0	16,0	16,0	16,0	16,0	16,0	16,0	16,0	16,0	16,0	16,0	6,0	
7,0	16,0	16,0	16,0	16,0	16,0	16,0	16,0	16,0	16,0	16,0	16,0	16,0	16,0	7,0	
8,0	15,5	16,0	16,0	16,0	16,0	16,0	16,0	16,0	16,0	16,0	16,0	16,0	16,0	8,0	
9,0	15,0	16,0	16,0	16,0	16,0	16,0	15,0	16,0	16,0	16,0	16,0	16,0	16,0	9,0	
10,0	14,5	15,5	15,5	15,5	15,5	15,5	14,0	16,0	16,0	16,0	16,0	16,0	16,0	10,0	
11,0	14,0	15,0	15,0	15,0	15,0	15,0	13,0	16,0	16,0	16,0	16,0	16,0	16,0	11,0	
12,0	13,5	14,5	14,5	14,5	14,5	14,5	12,0	16,0	16,0	16,0	16,0	16,0	16,0	12,0	
14,0		14,0	14,0	14,0	14,0	14,0	11,0	14,5	15,5	15,5	15,5	15,5	15,5	14,0	
16,0		13,5	13,5	13,5	13,5	13,5	10,0	13,0	15,0	15,0	15,0	14,5	14,5	16,0	
18,0							9,0	12,0	13,5	12,5	12,0	11,0	11,0	18,0	
20,0							8,0	11,0	11,5	10,5	10,0	9,0	9,0	20,0	
22,0														22,0	
24,0														24,0	
26,0														26,0	
28,0														28,0	
30,0														30,0	
32,0														32,0	
34,0														34,0	
36,0														36,0	
38,0														38,0	
40,0														40,0	
42,0														42,0	
44,0														44,0	
46,0														46,0	
Passagem Gancho	3												Passagem Gancho		
	18t														
Modo telescópico	I	1	1	1	1	1	1	1	1	1	1	1	2	I	Modo telescópico
	II	1	1	1	1	1	2	1	1	1	1	2	2	II	
	III	1	1	1	1	2	1	1	1	1	2	2	1	III	
	IV	1	1	1	2	1	1	1	1	2	2	1	1	IV	
	V	1	1	2	1	1	1	1	2	2	1	1	1	V	
	VI	1	2	1	1	1	1	3	2	1	1	1	1	VI	

Tabela 1-46 Tabela de capacidade de elevação (apenas com lança principal)

Unidade: tonelada

Estabilizadores totalmente estendidos para 8m, contrapeso de 19t, sobre a área de trabalho lateral ou traseira														
RAIO DE TRABALHO (m)	Comprimento da lança da ponta: 3m, deslocamento: 30°												RAIO DE TRABALHO (m)	
	25,8	25,8	25,8	25,8	25,8	25,8★	30,0	30,0	30,0	30,0	30,0	30,0★		
3,0														3,0
3,5														3,5
4,0														4,0
4,5														4,5
5,0														5,0
5,5	16,0	16,0	16,0	16,0	16,0	16,0								5,5
6,0	15,0	15,0	16,0	16,0	16,0	16,0								6,0
7,0	14,0	14,0	16,0	16,0	16,0	16,0	13,5	16,0	16,0	16,0	16,0	16,0	16,0	7,0
8,0	13,0	13,0	16,0	16,0	16,0	16,0	12,2	15,0	16,0	16,0	16,0	16,0	16,0	8,0
9,0	12,0	12,0	16,0	16,0	16,0	16,0	11,2	14,0	15,0	16,0	16,0	16,0	16,0	9,0
10,0	11,0	11,0	16,0	16,0	16,0	16,0	10,2	13,0	14,0	16,0	16,0	16,0	16,0	10,0
11,0	10,5	10,5	16,0	16,0	16,0	16,0	9,5	12,0	13,0	16,0	16,0	16,0	16,0	11,0
12,0	10,0	10,0	16,0	16,0	16,0	16,0	9,0	11,0	12,0	16,0	16,0	16,0	16,0	12,0
14,0	9,0	9,0	16,0	16,0	16,0	16,0	8,0	10,0	10,5	16,0	16,0	16,0	16,0	14,0
16,0	8,0	8,0	15,0	15,5	15,5	15,0	7,0	9,0	9,5	16,0	16,0	16,0	15,5	16,0
18,0	7,0	7,0	13,5	14,0	13,0	12,0	6,0	8,0	8,5	14,0	13,5	12,5	18,0	
20,0	6,5	6,5	12,0	11,5	10,5	9,5	5,5	7,3	7,5	12,0	11,0	10,0	20,0	
22,0	6,0	6,0	10,0	9,5	9,0	7,5	5,0	6,6	6,8	10,0	9,5	8,2	22,0	
24,0							4,5	6,0	6,2	8,5	8,0	6,7	24,0	
26,0							4,2	5,6	5,8	7,5	6,8	5,5	26,0	
28,0													28,0	
30,0													30,0	
32,0													32,0	
34,0													34,0	
36,0													36,0	
38,0													38,0	
40,0													40,0	
42,0													42,0	
44,0													44,0	
46,0													46,0	
Passagem	3												Passagem	
Gancho	18t												Gancho	
Modo telescópico	I	1	1	1	1	1	2	1	1	1	1	1	2	Modo telescópico
	II	1	1	1	1	2	2	1	1	1	1	2	2	
	III	1	1	1	2	2	2	1	1	1	2	2	2	
	IV	1	1	2	2	2	1	1	2	3	2	2	2	
	V	2	3	2	2	1	1	3	3	2	2	2	1	
	VI	3	2	2	1	1	1	3	2	2	2	1	1	

Descrição do Guindaste

Tabela 1-47 Tabela de capacidade de elevação (apenas com lança principal)

Unidade: tonelada

Estabilizadores totalmente estendidos para 8m, contrapeso de 19t, sobre a área de trabalho lateral ou traseira															
RAIO DE TRABALHO (m)	Comprimento da lança da ponta: 3m, deslocamento: 30°												RAIO DE TRABALHO (m)		
	34,2	34,2	34,2	34,2	34,2	34,2 ★	38,4	38,4	38,4	38,4	38,4	38,4		38,4 ★	
3,0														3,0	
3,5														3,5	
4,0														4,0	
4,5														4,5	
5,0														5,0	
5,5														5,5	
6,0														6,0	
7,0														7,0	
8,0	12,5	14,0	16,0	16,0	16,0	16,0								8,0	
9,0	11,5	13,0	16,0	16,0	16,0	16,0	12,0	14,0	16,0	16,0	16,0	16,0	16,0	9,0	
10,0	10,5	12,0	15,0	15,0	16,0	16,0	11,0	13,0	15,0	16,0	16,0	16,0	16,0	10,0	
11,0	10,0	11,0	14,0	14,0	16,0	16,0	10,0	12,0	14,0	16,0	16,0	16,0	16,0	11,0	
12,0	9,5	10,0	13,0	13,0	16,0	16,0	9,5	11,5	13,0	15,5	16,0	16,0	16,0	12,0	
14,0	8,5	9,0	12,0	12,0	15,0	16,0	8,1	10,0	11,0	14,0	15,0	15,5	15,5	14,0	
16,0	7,5	8,0	10,5	10,5	14,0	14,0	7,2	9,0	10,0	12,5	14,5	15,0	15,0	16,0	
18,0	6,5	7,0	9,5	9,5	13,5	12,5	6,3	8,0	8,8	11,0	13,0	13,5	13,5	18,0	
20,0	6,0	6,5	8,5	8,5	12,0	10,6	5,7	7,0	7,8	10,0	11,8	11,0	11,0	20,0	
22,0	5,5	5,8	7,7	7,7	10,0	8,9	5,1	6,5	7,0	9,0	9,8	9,5	9,5	22,0	
24,0	5,0	5,3	7,0	7,0	8,5	7,4	4,6	6,0	6,4	8,0	8,3	8,0	8,0	24,0	
26,0	4,5	4,8	6,5	6,5	7,2	6,1	4,2	5,5	5,8	7,0	7,0	6,6	6,6	26,0	
28,0	4,2	4,5	6,0	6,0	6,2	5,1	3,8	5,1	5,3	6,0	6,0	5,6	5,6	28,0	
30,0	3,9	4,2	5,5	5,5	5,3	4,2	3,5	4,7	4,8	5,2	5,1	4,7	4,7	30,0	
32,0							3,2	4,3	4,4	4,5	4,3	4,0	4,0	32,0	
34,0							3,0	3,9	4,1	3,8	3,6	3,3	3,3	34,0	
36,0														36,0	
38,0														38,0	
40,0														40,0	
42,0														42,0	
44,0														44,0	
46,0														46,0	
Passagem Gancho	3													Passagem Gancho	
	18t														
Modo telescópico	I	1	1	1	1	1	2	1	1	1	1	1	2	I	Modo telescópico
	II	1	1	1	1	2	2	1	1	1	2	3	2	II	
	III	1	1	2	3	2	2	1	2	3	3	2	2	III	
	IV	2	3	3	2	2	2	3	3	3	2	2	2	IV	
	V	3	3	2	2	2	2	3	3	2	2	2	2	V	
	VI	3	2	2	2	2	1	3	2	2	2	2	2	VI	

Tabela 1-48 Tabela de capacidade de elevação (apenas com lança principal)

Unidade: tonelada

Estabilizadores totalmente estendidos para 8m, contrapeso de 19t, sobre a área de trabalho lateral ou traseira														
RAIO DE TRABALHO (m)	Comprimento da lança da ponta: 3m, deslocamento: 30°												RAIO DE TRABALHO (m)	
	42,6	42,6	42,6	42,6	42,6	42,6★		46,8	46,8	46,8	46,8	46,8★		
3,0														3,0
3,5														3,5
4,0														4,0
4,5														4,5
5,0														5,0
5,5														5,5
6,0														6,0
7,0														7,0
8,0														8,0
9,0														9,0
10,0														10,0
11,0	10,5	12,0	14,0	16,0	16,0	16,0		10,5	12,0	14,0	16,0	16,0	11,0	
12,0	10,0	11,0	13,0	15,0	15,0	15,0		9,5	11,0	13,0	16,0	16,0	12,0	
14,0	9,0	9,5	11,5	13,5	14,5	14,5		9,0	10,5	12,5	15,0	15,0	14,0	
16,0	8,0	8,5	10,0	12,5	14,0	14,0		8,0	9,5	11,5	13,5	14,5	16,0	
18,0	7,1	7,7	9,1	11,5	13,0	13,0		7,0	8,5	10,0	12,0	13,0	18,0	
20,0	6,4	7,1	8,4	10,5	11,0	11,0		6,5	7,8	9,0	11,0	10,5	20,0	
22,0	5,8	6,3	7,6	9,5	9,4	9,0		5,7	7,0	8,5	9,5	9,0	22,0	
24,0	5,2	5,7	7,0	8,5	7,9	7,5		5,2	6,4	7,4	8,0	7,5	24,0	
26,0	4,8	5,2	6,4	7,2	6,6	6,2		4,8	5,8	6,8	6,7	6,2	26,0	
28,0	4,4	4,7	5,9	6,1	5,5	5,1		4,4	5,3	6,3	5,6	5,1	28,0	
30,0	4,1	4,3	5,3	5,2	4,6	4,2		4,0	4,8	5,4	4,7	4,2	30,0	
32,0	3,8	3,8	4,5	4,3	3,8	3,4		3,6	4,4	4,6	3,9	3,4	32,0	
34,0	3,5	3,5	4,0	3,6	3,1	2,7		3,3	4,0	3,9	3,3	2,8	34,0	
36,0	3,2	3,2	3,4	3,1	2,6	2,2		3,0	3,7	3,3	2,7	2,2	36,0	
38,0	3,0	3,0	2,9	2,6	2,1	1,7		2,7	3,1	2,8	2,2	1,7	38,0	
40,0								2,5	2,6	2,3	1,7	1,2	40,0	
42,0								2,3	2,2	1,9	1,3	0,8	42,0	
44,0													44,0	
46,0													46,0	
Passagem Gancho	3												Passagem Gancho	
	18t													
Modo telescópico	I	1	1	1	1	2	3		1	1	1	2	3	I
	II	1	1	2	3	3	2		1	2	3	3	3	II
	III	2	3	3	3	2	2		3	3	3	3	2	III
	IV	3	3	3	2	2	2		3	3	3	2	2	IV
	V	3	3	2	2	2	2		3	3	2	2	2	V
	VI	3	2	2	2	2	2		3	2	2	2	2	VI

Descrição do Guindaste

Tabela 1-49 Tabela de capacidade de elevação (apenas com lança principal)

Unidade: tonelada

Estabilizadores totalmente estendidos para 8m, contrapeso de 19t, sobre a área de trabalho lateral ou traseira															
RAIO DE TRABALHO (m)	Comprimento da lança da ponta: 3m, deslocamento: 30°												RAIO DE TRABALHO (m)		
	51,0	51,0	51,0	51,0★	55,2	55,2	55,2★		59,4	59,4★	63,6★	70,0★			
4,0														4,0	
4,5														4,5	
5,0														5,0	
5,5														5,5	
6,0														6,0	
7,0														7,0	
8,0														8,0	
9,0														9,0	
10,0														10,0	
11,0														11,0	
12,0														12,0	
14,0	9,5	11,0	12,5	14,0	9,5	11,0	12,0							14,0	
16,0	8,5	10,0	11,5	13,0	8,7	10,0	11,0		9,0	10,0				16,0	
18,0	7,5	9,0	10,5	12,0	8,1	9,3	10,0		8,5	9,5	7,8			18,0	
20,0	7,0	8,2	9,5	11,0	7,5	8,6	9,4		8,0	8,8	7,5	6,5		20,0	
22,0	6,5	7,5	8,7	9,0	6,9	8,0	8,8		7,5	8,2	7,2	6,2		22,0	
24,0	5,7	6,9	8,0	7,5	6,3	7,4	7,8		6,8	7,5	6,9	6,0		24,0	
26,0	5,2	6,3	7,0	6,2	5,8	6,8	6,5		6,2	6,9	6,4	5,7		26,0	
28,0	4,8	5,7	5,9	5,2	5,3	6,2	5,5		5,7	5,8	5,9	5,3		28,0	
30,0	4,4	5,3	5,0	4,4	4,8	5,2	4,6		5,3	4,9	5,3	4,9		30,0	
32,0	4,1	4,8	4,2	3,6	4,4	4,5	3,9		4,6	4,1	4,5	4,5		32,0	
34,0	3,8	4,1	3,5	2,9	4,1	3,8	3,2		4,0	3,5	3,8	3,9		34,0	
36,0	3,5	3,5	2,9	2,3	3,8	3,2	2,6		3,5	2,9	3,2	3,3		36,0	
38,0	3,2	3,0	2,4	1,8	3,3	2,6	2,0		3,0	2,4	2,7	2,8		38,0	
40,0	2,9	2,5	1,9	1,3	2,9	2,2	1,6		2,5	1,9	2,2	2,3		40,0	
42,0	2,5	2,1	1,5	0,9	2,5	1,8	1,2		2,1	1,5	1,8	1,9		42,0	
44,0					2,1	1,4	0,8		1,7	1,1	1,4	1,5		44,0	
46,0											1,0	1,1		46,0	
Passagem	3						2						Passagem		
Gancho	18t												Gancho		
Modo telescópico	I	1	1	2	3	1	2	3		2	3	3	4	I	Modo telescópico
	II	2	3	3	3	3	3	3		3	3	3	4	II	
	III	3	3	3	3	3	3	3		3	3	3	4	III	
	IV	3	3	3	2	3	3	3		3	3	3	4	IV	
	V	3	3	2	2	3	3	2		3	3	3	4	V	
	VI	3	2	2	2	3	2	2		3	2	3	4	VI	

Tabela 1-50 Tabela de capacidade de elevação (apenas com lança principal)

Unidade: tonelada

Estabilizadores totalmente estendidos para 8m, contrapeso de 15t, sobre a área de trabalho lateral ou traseira														
RAIO DE TRABALHO (m)	Comprimento da lança da ponta: 3m, deslocamento: 30°												RAIO DE TRABALHO (m)	
	13,2 ★	17,4	17,4	17,4	17,4	17,4 ★	21,6	21,6	21,6	21,6	21,6	21,6 ★		
3,0	18,0													3,0
3,5	16,0	16,0	16,0	16,0	16,0	16,0								3,5
4,0	16,0	16,0	16,0	16,0	16,0	16,0								4,0
4,5	16,0	16,0	16,0	16,0	16,0	16,0	16,0	16,0	16,0	16,0	16,0	16,0	16,0	4,5
5,0	16,0	16,0	16,0	16,0	16,0	16,0	16,0	16,0	16,0	16,0	16,0	16,0	16,0	5,0
5,5	16,0	16,0	16,0	16,0	16,0	16,0	16,0	16,0	16,0	16,0	16,0	16,0	16,0	5,5
6,0	16,0	16,0	16,0	16,0	16,0	16,0	16,0	16,0	16,0	16,0	16,0	16,0	16,0	6,0
7,0	16,0	16,0	16,0	16,0	16,0	16,0	16,0	16,0	16,0	16,0	16,0	16,0	16,0	7,0
8,0	15,5	16,0	16,0	16,0	16,0	16,0	16,0	16,0	16,0	16,0	16,0	16,0	16,0	8,0
9,0	15,0	16,0	16,0	16,0	16,0	16,0	15,0	16,0	16,0	16,0	16,0	16,0	16,0	9,0
10,0	14,5	15,5	15,5	15,5	15,5	15,5	14,0	16,0	16,0	16,0	16,0	16,0	16,0	10,0
11,0	14,0	15,0	15,0	15,0	15,0	15,0	13,0	16,0	16,0	16,0	16,0	16,0	16,0	11,0
12,0	13,5	14,5	14,5	14,5	14,5	14,5	12,0	16,0	16,0	16,0	16,0	16,0	16,0	12,0
14,0		14,0	14,0	14,0	14,0	14,0	11,0	14,5	15,5	15,5	15,5	15,5	15,5	14,0
16,0		13,5	13,5	13,5	13,5	13,0	10,0	13,0	15,0	14,5	13,5	12,5	12,5	16,0
18,0							9,0	12,0	12,5	11,8	11,0	10,0	10,0	18,0
20,0							8,0	10,5	10,0	9,5	8,8	7,8	7,8	20,0
22,0														22,0
24,0														24,0
26,0														26,0
28,0														28,0
30,0														30,0
32,0														32,0
34,0														34,0
36,0														36,0
38,0														38,0
40,0														40,0
42,0														42,0
44,0														44,0
Passagem Gancho	3												Passagem Gancho	
	18t													
Modo telescópico	I	1	1	1	1	1	1	1	1	1	1	1	2	I
	II	1	1	1	1	1	2	1	1	1	1	2	2	II
	III	1	1	1	1	2	1	1	1	1	2	2	1	III
	IV	1	1	1	2	1	1	1	1	2	2	1	1	IV
	V	1	1	2	1	1	1	1	2	2	1	1	1	V
	VI	1	2	1	1	1	1	3	2	1	1	1	1	VI

Descrição do Guindaste

Tabela 1-51 Tabela de capacidade de elevação (apenas com lança principal)

Unidade: tonelada

Estabilizadores totalmente estendidos para 8m, contrapeso de 15t, sobre a área de trabalho lateral ou traseira														
RAIO DE TRABALHO (m)	Comprimento da lança da ponta: 3m, deslocamento: 30°												RAIO DE TRABALHO (m)	
	25,8	25,8	25,8	25,8	25,8	25,8 ★	30,0	30,0	30,0	30,0	30,0	30,0		30,0 ★
3,0														3,0
3,5														3,5
4,0														4,0
4,5														4,5
5,0														5,0
5,5	16,0	16,0	16,0	16,0	16,0	16,0								5,5
6,0	15,0	15,0	16,0	16,0	16,0	16,0								6,0
7,0	14,0	14,0	16,0	16,0	16,0	16,0	13,5	16,0	16,0	16,0	16,0	16,0	16,0	7,0
8,0	13,0	13,0	16,0	16,0	16,0	16,0	12,2	15,0	16,0	16,0	16,0	16,0	16,0	8,0
9,0	12,0	12,0	16,0	16,0	16,0	16,0	11,2	14,0	15,0	16,0	16,0	16,0	16,0	9,0
10,0	11,0	11,0	16,0	16,0	16,0	16,0	10,2	13,0	14,0	16,0	16,0	16,0	16,0	10,0
11,0	10,5	10,5	16,0	16,0	16,0	16,0	9,5	12,0	13,0	16,0	16,0	16,0	16,0	11,0
12,0	10,0	10,0	16,0	16,0	16,0	16,0	9,0	11,0	12,0	16,0	16,0	16,0	16,0	12,0
14,0	9,0	9,0	16,0	16,0	16,0	16,0	8,0	10,0	10,5	16,0	16,0	16,0	16,0	14,0
16,0	8,0	8,0	15,0	15,5	14,5	13,5	7,0	9,0	9,5	16,0	15,0	14,0	16,0	16,0
18,0	7,0	7,0	13,0	12,5	11,5	10,5	6,0	8,0	8,5	13,0	12,0	11,0	11,0	18,0
20,0	6,5	6,5	11,0	10,3	9,5	8,3	5,5	7,3	7,5	11,0	10,0	8,8	8,8	20,0
22,0	6,0	6,0	9,2	8,5	7,7	6,5	5,0	6,6	6,8	9,2	8,3	7,1	7,1	22,0
24,0							4,5	6,0	6,2	7,8	6,9	5,7	5,7	24,0
26,0							4,2	5,6	5,8	6,6	5,7	4,5	4,5	26,0
28,0														28,0
30,0														30,0
32,0														32,0
34,0														34,0
36,0														36,0
38,0														38,0
40,0														40,0
42,0														42,0
44,0														44,0
Passagem	3													Passagem
Gancho	18t													Gancho
Modo telescópico	I	1	1	1	1	1	2	1	1	1	1	1	2	I
	II	1	1	1	1	2	2	1	1	1	1	2	2	II
	III	1	1	1	2	2	2	1	1	1	2	2	2	III
	IV	1	1	2	2	2	1	1	2	3	2	2	2	IV
	V	2	3	2	2	1	1	3	3	2	2	2	1	V
	VI	3	2	2	1	1	1	3	2	2	2	1	1	VI
														Modo telescópico

Tabela 1-52 Tabela de capacidade de elevação (apenas com lança principal)

Unidade: tonelada

Estabilizadores totalmente estendidos para 8m, contrapeso de 15t, sobre a área de trabalho lateral ou traseira															
RAIO DE TRABALHO (m)	Comprimento da lança da ponta: 3m, deslocamento: 30°												RAIO DE TRABALHO (m)		
	34,2	34,2	34,2	34,2	34,2	34,2★	38,4	38,4	38,4	38,4	38,4	38,4		38,4★	
3,0														3,0	
3,5														3,5	
4,0														4,0	
4,5														4,5	
5,0														5,0	
5,5														5,5	
6,0														6,0	
7,0														7,0	
8,0	12,5	14,0	16,0	16,0	16,0	16,0								8,0	
9,0	11,5	13,0	16,0	16,0	16,0	16,0	12,0	14,0	16,0	16,0	16,0	16,0	16,0	9,0	
10,0	10,5	12,0	15,0	15,0	16,0	16,0	11,0	13,0	15,0	16,0	16,0	16,0	16,0	10,0	
11,0	10,0	11,0	14,0	14,0	16,0	16,0	10,0	12,0	14,0	16,0	16,0	16,0	16,0	11,0	
12,0	9,5	10,0	13,0	13,0	16,0	16,0	9,5	11,5	13,0	15,5	16,0	16,0	16,0	12,0	
14,0	8,5	9,0	12,0	12,0	15,0	16,0	8,1	10,0	11,0	14,0	15,0	15,5	14,0	14,0	
16,0	7,5	8,0	10,5	10,5	14,0	14,0	7,2	9,0	10,0	12,5	14,5	15,0	16,0	16,0	
18,0	6,5	7,0	9,5	9,5	13,0	11,5	6,3	8,0	8,8	11,0	12,5	12,0	18,0	18,0	
20,0	6,0	6,5	8,5	8,5	10,7	9,5	5,7	7,0	7,8	10,0	10,5	10,0	20,0	20,0	
22,0	5,5	5,8	7,7	7,7	8,9	7,7	5,1	6,5	7,0	8,9	8,6	8,3	22,0	22,0	
24,0	5,0	5,3	7,0	7,0	7,5	6,3	4,6	6,0	6,4	7,5	7,2	6,9	24,0	24,0	
26,0	4,5	4,8	6,5	6,5	6,3	5,1	4,2	5,5	5,8	6,3	6,0	5,7	26,0	26,0	
28,0	4,2	4,5	5,7	5,5	5,3	4,1	3,8	5,1	5,3	5,3	5,0	4,7	28,0	28,0	
30,0	3,9	4,2	4,8	4,6	4,5	3,3	3,5	4,7	4,8	4,5	4,2	3,9	30,0	30,0	
32,0							3,2	4,3	4,0	3,7	3,5	3,2	32,0	32,0	
34,0							3,0	3,8	3,5	3,2	3,0	2,6	34,0	34,0	
36,0													36,0	36,0	
38,0													38,0	38,0	
40,0													40,0	40,0	
42,0													42,0	42,0	
44,0													44,0	44,0	
Passagem Gancho	3													Passagem Gancho	
	18t														
Modo telescópico	I	1	1	1	1	1	2	1	1	1	1	1	2	I	Modo telescópico
	II	1	1	1	1	2	2	1	1	1	2	3	2	II	
	III	1	1	2	3	2	2	1	2	3	3	2	2	III	
	IV	2	3	3	2	2	2	3	3	3	2	2	2	IV	
	V	3	3	2	2	2	2	3	3	2	2	2	2	V	
	VI	3	2	2	2	2	1	3	2	2	2	2	2	VI	

Descrição do Guindaste

Tabela 1-53 Tabela de capacidade de elevação (apenas com lança principal)

Unidade: tonelada

Estabilizadores totalmente estendidos para 8m, contrapeso de 15t, sobre a área de trabalho lateral ou traseira															
RAIO DE TRABALHO (m)	Comprimento da lança da ponta: 3m, deslocamento: 30°											RAIO DE TRABALHO (m)			
	42,6	42,6	42,6	42,6	42,6	42,6 ★		46,8	46,8	46,8	46,8		46,8 ★		
3,0														3,0	
3,5														3,5	
4,0														4,0	
4,5														4,5	
5,0														5,0	
5,5														5,5	
6,0														6,0	
7,0														7,0	
8,0														8,0	
9,0														9,0	
10,0														10,0	
11,0	10,5	12,0	14,0	16,0	16,0	16,0		10,5	12,0	14,0	16,0	16,0		11,0	
12,0	10,0	11,0	13,0	15,0	15,0	15,0		9,5	11,0	13,0	16,0	16,0		12,0	
14,0	9,0	9,5	11,5	13,5	14,5	14,5		9,0	10,5	12,5	15,0	15,0		14,0	
16,0	8,0	8,5	10,0	12,5	14,0	14,0		8,0	9,5	11,5	13,5	14,5		16,0	
18,0	7,1	7,7	9,1	11,5	12,0	11,6		7,0	8,5	10,0	12,0	11,5		18,0	
20,0	6,4	7,1	8,4	10,5	10,0	9,6		6,5	7,8	9,0	10,0	9,5		20,0	
22,0	5,8	6,3	7,6	8,7	8,2	7,8		5,7	7,0	8,5	8,3	7,8		22,0	
24,0	5,2	5,7	7,0	7,3	6,8	6,4		5,2	6,4	7,5	6,9	6,4		24,0	
26,0	4,8	5,2	6,3	6,1	5,6	5,2		4,8	5,8	6,3	5,7	5,2		26,0	
28,0	4,4	4,7	5,4	5,2	4,7	4,3		4,4	5,3	5,3	4,7	4,2		28,0	
30,0	4,1	4,3	4,5	4,3	3,8	3,4		4,0	4,8	4,5	3,9	3,4		30,0	
32,0	3,8	3,8	4,0	3,6	3,1	2,7		3,6	4,2	3,8	3,2	2,7		32,0	
34,0	3,5	3,5	3,3	2,9	2,4	2,0		3,3	3,5	3,1	2,5	2,0		34,0	
36,0	3,2	3,2	2,8	2,4	1,9	1,5		3,0	3,0	2,6	2,0	1,5		36,0	
38,0	3,0	2,7	2,3	1,9	1,4	1,0		2,7	2,5	2,1	1,5	1,0		38,0	
40,0														40,0	
42,0														42,0	
44,0														44,0	
Passagem Gancho	3												Passagem Gancho		
	18t														
Modo telescópico	I	1	1	1	1	2	3		1	1	1	2	3	I	Modo telescópico
	II	1	1	2	3	3	2		1	2	3	3	3	II	
	III	2	3	3	3	2	2		3	3	3	3	2	III	
	IV	3	3	3	2	2	2		3	3	3	2	2	IV	
	V	3	3	2	2	2	2		3	3	2	2	2	V	
	VI	3	2	2	2	2	2		3	2	2	2	2	VI	

Tabela 1-54 Tabela de capacidade de elevação (apenas com lança principal)

Unidade: tonelada

Estabilizadores totalmente estendidos para 8m, contrapeso de 15t, sobre a área de trabalho lateral ou traseira														
RAIO DE TRABALHO (m)	Comprimento da lança da ponta: 3m, deslocamento: 30°												RAIO DE TRABALHO (m)	
	51,0	51,0	51,0	51,0 ★	55,2	55,2	55,2 ★		59,4	59,4 ★	63,6 ★	70,0 ★		
4,0														4,0
4,5														4,5
5,0														5,0
5,5														5,5
6,0														6,0
7,0														7,0
8,0														8,0
9,0														9,0
10,0														10,0
11,0														11,0
12,0														12,0
14,0	9,5	11,0	12,5	14,0	9,5	11,0	12,0							14,0
16,0	8,5	10,0	11,5	13,0	8,7	10,0	11,0		9,0	10,0				16,0
18,0	7,5	9,0	10,5	12,0	8,1	9,3	10,0		8,5	9,5	7,8			18,0
20,0	7,0	8,2	9,5	10,8	7,5	8,6	9,4		8,0	8,8	7,5	6,5		20,0
22,0	6,5	7,5	8,6	8,0	6,9	8,0	8,2		7,5	8,2	7,2	6,2		22,0
24,0	5,7	6,9	7,1	6,5	6,3	7,4	6,7		6,8	7,0	6,9	6,0		24,0
26,0	5,2	6,3	5,9	5,4	5,8	6,2	5,5		6,2	5,8	6,2	5,7		26,0
28,0	4,8	5,6	4,9	4,4	5,3	5,2	4,5		5,6	4,9	5,2	5,3		28,0
30,0	4,4	4,8	4,1	3,6	4,8	4,4	3,7		4,7	4,0	4,4	4,5		30,0
32,0	4,1	4,1	3,4	2,8	4,3	3,6	2,9		4,0	3,3	3,7	3,8		32,0
34,0	3,8	3,5	2,8	2,2	3,8	3,1	2,4		3,3	2,6	3,1	3,2		34,0
36,0	3,3	2,9	2,2	1,6	3,2	2,5	1,8		2,7	2,0	2,5	2,6		36,0
38,0	2,8	2,4	1,7	1,1	2,7	2,0	1,3		2,3	1,6	2,0	2,1		38,0
40,0					2,3	1,6	0,9		1,9	1,2	1,6	1,7		40,0
42,0									1,5	0,8	1,2	1,3		42,0
44,0											0,8	0,9		44,0
Passagem Gancho	3							2						Passagem Gancho
Modo telescópico	I	1	1	2	3	1	2	3		2	3	3	4	I
	II	2	3	3	3	3	3	3		3	3	3	4	II
	III	3	3	3	3	3	3	3		3	3	3	4	III
	IV	3	3	3	2	3	3	3		3	3	3	4	IV
	V	3	3	2	2	3	3	2		3	3	3	4	V
	VI	3	2	2	2	3	2	2		3	2	3	4	VI

Descrição do Guindaste

Tabela 1-55 Tabela de capacidade de elevação (apenas com lança principal)

Unidade: tonelada

Estabilizadores totalmente estendidos para 8m, contrapeso de 11t, sobre a área de trabalho lateral ou traseira															
RAIO DE TRABALHO (m)	Comprimento da lança da ponta: 3m, deslocamento: 30°												RAIO DE TRABALHO (m)		
	13,2 ★	17,4	17,4	17,4	17,4	17,4 ★	21,6	21,6	21,6	21,6	21,6	21,6 ★			
3,0	18,0													3,0	
3,5	16,0	16,0	16,0	16,0	16,0	16,0								3,5	
4,0	16,0	16,0	16,0	16,0	16,0	16,0								4,0	
4,5	16,0	16,0	16,0	16,0	16,0	16,0	16,0	16,0	16,0	16,0	16,0	16,0	16,0	4,5	
5,0	16,0	16,0	16,0	16,0	16,0	16,0	16,0	16,0	16,0	16,0	16,0	16,0	16,0	5,0	
5,5	16,0	16,0	16,0	16,0	16,0	16,0	16,0	16,0	16,0	16,0	16,0	16,0	16,0	5,5	
6,0	16,0	16,0	16,0	16,0	16,0	16,0	16,0	16,0	16,0	16,0	16,0	16,0	16,0	6,0	
7,0	16,0	16,0	16,0	16,0	16,0	16,0	16,0	16,0	16,0	16,0	16,0	16,0	16,0	7,0	
8,0	15,5	16,0	16,0	16,0	16,0	16,0	16,0	16,0	16,0	16,0	16,0	16,0	16,0	8,0	
9,0	15,0	16,0	16,0	16,0	16,0	16,0	15,0	16,0	16,0	16,0	16,0	16,0	16,0	9,0	
10,0	14,5	15,5	15,5	15,5	15,5	15,5	14,0	16,0	16,0	16,0	16,0	16,0	16,0	10,0	
11,0	14,0	15,0	15,0	15,0	15,0	15,0	13,0	16,0	16,0	16,0	16,0	16,0	16,0	11,0	
12,0	13,5	14,5	14,5	14,5	14,5	14,5	12,0	16,0	16,0	16,0	16,0	16,0	16,0	12,0	
14,0		14,0	14,0	14,0	14,0	14,0	11,0	14,5	15,5	15,5	15,5	14,5	14,5	14,0	
16,0		13,0	13,0	12,5	12,0	11,5	10,0	13,0	13,5	13,0	12,0	11,0	11,0	16,0	
18,0							9,0	11,0	10,5	10,2	9,5	8,3	8,3	18,0	
20,0							8,0	9,0	8,5	8,2	7,5	6,3	6,3	20,0	
22,0														22,0	
24,0														24,0	
26,0														26,0	
28,0														28,0	
30,0														30,0	
32,0														32,0	
34,0														34,0	
36,0														36,0	
38,0														38,0	
40,0														40,0	
Passagem	3												Passagem		
Gancho	18t												Gancho		
Modo telescópico	I	1	1	1	1	1	1	1	1	1	1	1	2	I	Modo telescópico
	II	1	1	1	1	1	2	1	1	1	1	2	2	II	
	III	1	1	1	1	2	1	1	1	1	2	2	1	III	
	IV	1	1	1	2	1	1	1	1	2	2	1	1	IV	
	V	1	1	2	1	1	1	1	2	2	1	1	1	V	
	VI	1	2	1	1	1	1	3	2	1	1	1	1	VI	

Tabela 1-56 Tabela de capacidade de elevação (apenas com lança principal)

Unidade: tonelada

Estabilizadores totalmente estendidos para 8m, contrapeso de 11t, sobre a área de trabalho lateral ou traseira															
RAIO DE TRABALHO (m)	Comprimento da lança da ponta: 3m, deslocamento: 30°												RAIO DE TRABALHO (m)		
	25,8	25,8	25,8	25,8	25,8	25,8 ★	30,0	30,0	30,0	30,0	30,0	30,0 ★			
3,0														3,0	
3,5														3,5	
4,0														4,0	
4,5														4,5	
5,0														5,0	
5,5	16,0	16,0	16,0	16,0	16,0	16,0								5,5	
6,0	15,0	15,0	16,0	16,0	16,0	16,0								6,0	
7,0	14,0	14,0	16,0	16,0	16,0	16,0	13,5	16,0	16,0	16,0	16,0	16,0	16,0	7,0	
8,0	13,0	13,0	16,0	16,0	16,0	16,0	12,2	15,0	16,0	16,0	16,0	16,0	16,0	8,0	
9,0	12,0	12,0	16,0	16,0	16,0	16,0	11,2	14,0	15,0	16,0	16,0	16,0	16,0	9,0	
10,0	11,0	11,0	16,0	16,0	16,0	16,0	10,2	13,0	14,0	16,0	16,0	16,0	16,0	10,0	
11,0	10,5	10,5	16,0	16,0	16,0	16,0	9,5	12,0	13,0	16,0	16,0	16,0	16,0	11,0	
12,0	10,0	10,0	16,0	16,0	16,0	16,0	9,0	11,0	12,0	16,0	16,0	16,0	16,0	12,0	
14,0	9,0	9,0	16,0	16,0	16,0	15,0	8,0	10,0	10,5	16,0	16,0	16,0	16,0	14,0	
16,0	8,0	8,0	14,5	13,5	12,5	11,5	7,0	9,0	9,5	14,5	13,5	13,5	12,0	16,0	
18,0	7,0	7,0	11,5	11,0	10,0	9,0	6,0	8,0	8,5	11,5	10,7	9,5	9,5	18,0	
20,0	6,5	6,5	9,5	8,9	8,0	6,8	5,5	7,3	7,5	9,5	8,7	7,5	7,5	20,0	
22,0	6,0	6,0	7,9	7,3	6,4	5,2	5,0	6,6	6,8	7,9	7,1	5,8	5,8	22,0	
24,0							4,5	6,0	6,2	6,5	5,7	4,5	4,5	24,0	
26,0							4,2	5,6	5,7	5,5	4,7	3,5	3,5	26,0	
28,0														28,0	
30,0														30,0	
32,0														32,0	
34,0														34,0	
36,0														36,0	
38,0														38,0	
40,0														40,0	
Passagem	3													Passagem	
Gancho	18t													Gancho	
Modo telescópico	I	1	1	1	1	1	2	1	1	1	1	1	2	I	Modo telescópico
	II	1	1	1	1	2	2	1	1	1	1	2	2	II	
	III	1	1	1	2	2	2	1	1	1	2	2	2	III	
	IV	1	1	2	2	2	1	1	2	3	2	2	2	IV	
	V	2	3	2	2	1	1	3	3	2	2	2	1	V	
	VI	3	2	2	1	1	1	3	2	2	2	1	1	VI	

Descrição do Guindaste

Tabela 1-57 Tabela de capacidade de elevação (apenas com lança principal)

Unidade: tonelada

Estabilizadores totalmente estendidos para 8m, contrapeso de 11t, sobre a área de trabalho lateral ou traseira														
RAIO DE TRABALHO (m)	Comprimento da lança da ponta: 3m, deslocamento: 30°												RAIO DE TRABALHO (m)	
	34,2	34,2	34,2	34,2	34,2	34,2★	38,4	38,4	38,4	38,4	38,4	38,4★		
3,0														3,0
3,5														3,5
4,0														4,0
4,5														4,5
5,0														5,0
5,5														5,5
6,0														6,0
7,0														7,0
8,0	12,5	14,0	16,0	16,0	16,0	16,0								8,0
9,0	11,5	13,0	16,0	16,0	16,0	16,0	12,0	14,0	16,0	16,0	16,0	16,0	16,0	9,0
10,0	10,5	12,0	15,0	15,0	16,0	16,0	11,0	13,0	15,0	16,0	16,0	16,0	16,0	10,0
11,0	10,0	11,0	14,0	14,0	16,0	16,0	10,0	12,0	14,0	16,0	16,0	16,0	16,0	11,0
12,0	9,5	10,0	13,0	13,0	16,0	16,0	9,5	11,5	13,0	15,5	16,0	16,0	16,0	12,0
14,0	8,5	9,0	12,0	12,0	15,0	16,0	8,1	10,0	11,0	14,0	15,0	15,5	14,0	14,0
16,0	7,5	8,0	10,5	10,5	14,0	12,8	7,2	9,0	10,0	12,5	14,0	13,5	16,0	16,0
18,0	6,5	7,0	9,5	9,5	11,5	10,0	6,3	8,0	8,8	11,0	11,0	10,6	18,0	18,0
20,0	6,0	6,5	8,5	8,5	9,3	8,0	5,7	7,0	7,8	9,3	9,0	8,7	20,0	20,0
22,0	5,5	5,8	7,7	7,7	7,7	6,5	5,1	6,5	7,0	7,6	7,4	7,1	22,0	22,0
24,0	5,0	5,3	6,7	6,5	6,3	5,1	4,6	6,0	6,4	6,3	6,1	5,8	24,0	24,0
26,0	4,5	4,8	5,7	5,5	5,3	4,1	4,2	5,5	5,6	5,2	5,0	4,7	26,0	26,0
28,0	4,2	4,5	4,8	4,6	4,4	3,2	3,8	5,1	4,7	4,3	4,1	3,8	28,0	28,0
30,0	3,9	4,2	4,0	3,8	3,6	2,4	3,5	4,2	4,0	3,6	3,4	3,0	30,0	30,0
32,0							3,2	3,6	3,4	3,0	2,8	2,4	32,0	32,0
34,0							3,0	3,0	2,8	2,4	2,2	1,8	34,0	34,0
36,0													36,0	36,0
38,0													38,0	38,0
40,0													40,0	40,0
Passagem	3													Passagem
Gancho	18t													Gancho
Modo telescópico	I	1	1	1	1	1	2	1	1	1	1	1	2	I
	II	1	1	1	1	2	2	1	1	1	2	3	2	II
	III	1	1	2	3	2	2	1	2	3	3	2	2	III
	IV	2	3	3	2	2	2	3	3	3	2	2	2	IV
	V	3	3	2	2	2	2	3	3	2	2	2	2	V
	VI	3	2	2	2	2	1	3	2	2	2	2	2	VI

Tabela 1-58 Tabela de capacidade de elevação (apenas com lança principal)

Unidade: tonelada

Estabilizadores totalmente estendidos para 8m, contrapeso de 11t, sobre a área de trabalho lateral ou traseira															
RAIO DE TRABALHO (m)	Comprimento da lança da ponta: 3m, deslocamento: 30°												RAIO DE TRABALHO (m)		
	42,6	42,6	42,6	42,6	42,6	42,6 ★		46,8	46,8	46,8	46,8	46,8 ★			
3,0														3,0	
3,5														3,5	
4,0														4,0	
4,5														4,5	
5,0														5,0	
5,5														5,5	
6,0														6,0	
7,0														7,0	
8,0														8,0	
9,0														9,0	
10,0														10,0	
11,0	10,5	12,0	14,0	16,0	16,0	16,0		10,5	12,0	14,0	16,0	16,0	16,0	11,0	
12,0	10,0	11,0	13,0	15,0	15,0	15,0		9,5	11,0	13,0	16,0	16,0	16,0	12,0	
14,0	9,0	9,5	11,5	13,5	14,5	14,5		9,0	10,5	12,5	15,0	15,0	15,0	14,0	
16,0	8,0	8,5	10,0	12,5	13,0	13,0		8,0	9,5	11,5	13,5	13,0	13,0	16,0	
18,0	7,1	7,7	9,1	11,2	10,5	10,2		7,0	8,5	10,0	10,7	10,2	10,2	18,0	
20,0	6,4	7,1	8,4	9,0	8,5	8,2		6,5	7,8	9,0	8,6	8,0	8,0	20,0	
22,0	5,8	6,3	7,8	7,4	6,9	6,6		5,7	7,0	7,5	7,0	6,5	6,5	22,0	
24,0	5,2	5,7	6,5	6,1	5,6	5,3		5,2	6,4	6,3	5,7	5,2	5,2	24,0	
26,0	4,8	5,2	5,5	5,1	4,5	4,2		4,8	5,7	5,2	4,7	5,2	5,2	26,0	
28,0	4,4	4,7	4,5	4,1	3,6	3,3		4,4	4,8	4,3	3,8	3,3	3,3	28,0	
30,0	4,1	4,3	3,7	3,4	2,9	2,6		4,0	4,0	3,6	3,0	2,5	2,5	30,0	
32,0	3,8	3,5	3,0	2,7	2,2	1,9		3,6	3,4	3,0	2,3	1,8	1,8	32,0	
34,0	3,4	3,0	2,5	2,2	1,7	1,3		3,3	2,8	2,4	1,8	1,3	1,3	34,0	
36,0	2,9	2,5	2,0	1,7	1,2	0,8		2,8	2,3	1,9	1,3	0,8	0,8	36,0	
38,0														38,0	
40,0														40,0	
Passagem Gancho	3												Passagem Gancho		
	18t														
Modo telescópico	I	1	1	1	1	2	3		1	1	1	2	3	I	Modo telescópico
	II	1	1	2	3	3	2		1	2	3	3	3	II	
	III	2	3	3	3	2	2		3	3	3	3	2	III	
	IV	3	3	3	2	2	2		3	3	3	2	2	IV	
	V	3	3	2	2	2	2		3	3	2	2	2	V	
	VI	3	2	2	2	2	2		3	2	2	2	2	VI	

Tabela 1-59 Tabela de capacidade de elevação (apenas com lança principal)

Unidade: tonelada

Estabilizadores totalmente estendidos para 8m, contrapeso de 11t, sobre a área de trabalho lateral ou traseira														
RAIO DE TRABALHO (m)	Comprimento da lança da ponta: 3m, deslocamento: 30°												RAIO DE TRABALHO (m)	
	51,0	51,0	51,0	51,0 ★	55,2	55,2	55,2 ★		59,4	59,4 ★	63,6 ★	70,0 ★		
4,0														4,0
4,5														4,5
5,0														5,0
5,5														5,5
6,0														6,0
7,0														7,0
8,0														8,0
9,0														9,0
10,0														10,0
11,0														11,0
12,0														12,0
14,0	9,5	11,0	12,5	14,0	9,5	11,0	12,0							14,0
16,0	8,5	10,0	11,5	13,0	8,7	10,0	11,0		9,0	10,0				16,0
18,0	7,5	9,0	10,5	10,4	8,1	9,3	10,0		8,5	9,5	7,8			18,0
20,0	7,0	8,2	8,9	8,3	7,5	8,6	8,5		8,0	8,8	7,5	6,5		20,0
22,0	6,5	7,5	7,3	6,7	6,9	7,5	6,8		7,5	7,3	7,2	6,2		22,0
24,0	5,7	6,6	6,0	5,4	6,3	6,2	5,5		6,6	6,0	6,3	6,0		24,0
26,0	5,2	5,5	4,9	4,3	5,8	5,2	4,5		5,5	4,9	5,2	5,4		26,0
28,0	4,8	4,6	3,9	3,3	5,0	4,3	3,6		4,6	4,0	4,3	4,5		28,0
30,0	4,3	3,9	3,2	2,6	4,2	3,5	2,8		3,8	3,2	3,5	3,7		30,0
32,0	3,7	3,3	2,6	2,0	3,6	2,9	2,2		3,1	2,5	2,8	3,0		32,0
34,0	3,1	2,7	2,0	1,4	3,0	2,3	1,6		2,5	1,9	2,2	2,4		34,0
36,0	2,6	2,2	1,5	0,9	2,5	1,8	1,1		2,0	1,4	1,7	1,9		36,0
38,0									1,6	1,0	1,3	1,4		38,0
40,0											0,9	1,0		40,0
Passagem	3						2						Passagem	
Gancho	18t												Gancho	
Modo telescópico	I	1	1	2	3	1	2	3		2	3	3	4	I
	II	2	3	3	3	3	3	3		3	3	3	4	II
	III	3	3	3	3	3	3	3		3	3	3	4	III
	IV	3	3	3	2	3	3	3		3	3	3	4	IV
	V	3	3	2	2	3	3	2		3	3	3	4	V
	VI	3	2	2	2	3	2	2		3	2	3	4	VI

Tabela 1-60 Tabela de capacidade de elevação (apenas com lança principal)

Unidade: tonelada

Estabilizadores totalmente estendidos para 8m, contrapeso de 3t, sobre a área de trabalho lateral ou traseira														
RAIO DE TRABALHO (m)	Comprimento da lança da ponta: 3m, deslocamento: 30°												RAIO DE TRABALHO (m)	
	13,2 ★	17,4	17,4	17,4	17,4	17,4 ★	21,6	21,6	21,6	21,6	21,6	21,6		21,6 ★
3,0	18,0													3,0
3,5	16,0	16,0	16,0	16,0	16,0	16,0								3,5
4,0	16,0	16,0	16,0	16,0	16,0	16,0								4,0
4,5	16,0	16,0	16,0	16,0	16,0	16,0	16,0	16,0	16,0	16,0	16,0	16,0	16,0	4,5
5,0	16,0	16,0	16,0	16,0	16,0	16,0	16,0	16,0	16,0	16,0	16,0	16,0	16,0	5,0
5,5	16,0	16,0	16,0	16,0	16,0	16,0	16,0	16,0	16,0	16,0	16,0	16,0	16,0	5,5
6,0	16,0	16,0	16,0	16,0	16,0	16,0	16,0	16,0	16,0	16,0	16,0	16,0	16,0	6,0
7,0	16,0	16,0	16,0	16,0	16,0	16,0	16,0	16,0	16,0	16,0	16,0	16,0	16,0	7,0
8,0	15,5	16,0	16,0	16,0	16,0	16,0	16,0	16,0	16,0	16,0	16,0	16,0	16,0	8,0
9,0	15,0	16,0	16,0	16,0	16,0	16,0	15,0	16,0	16,0	16,0	16,0	16,0	16,0	9,0
10,0	14,5	15,5	15,5	15,5	15,5	15,5	14,0	16,0	16,0	16,0	16,0	16,0	16,0	10,0
11,0	14,0	15,0	15,0	15,0	15,0	14,5	13,0	16,0	16,0	16,0	16,0	15,0	13,5	11,0
12,0	13,5	14,0	13,5	12,8	12,5	12,1	12,0	16,0	15,0	14,0	13,0	11,9	11,9	12,0
14,0		12,2	11,7	11,4	11,1	10,7	11,0	13,0	12,5	11,8	11,0	9,9	9,9	14,0
16,0		9,5	9,0	8,7	8,4	8,0	10,0	10,5	10,0	9,3	8,5	7,4	7,4	16,0
18,0							8,3	8,0	7,5	7,0	6,2	5,1	5,1	18,0
20,0							6,6	6,3	5,8	5,3	4,5	3,4	3,4	20,0
22,0														22,0
24,0														24,0
26,0														26,0
28,0														28,0
30,0														30,0
32,0														32,0
Passagem	3												Passagem	
Gancho	18t												Gancho	
Modo telescópico	I	1	1	1	1	1	1	1	1	1	1	1	2	I
	II	1	1	1	1	1	2	1	1	1	1	2	2	II
	III	1	1	1	1	2	1	1	1	1	2	2	1	III
	IV	1	1	1	2	1	1	1	1	2	2	1	1	IV
	V	1	1	2	1	1	1	1	2	2	1	1	1	V
	VI	1	2	1	1	1	1	3	2	1	1	1	1	VI

Tabela 1-61 Tabela de capacidade de elevação (apenas com lança principal)

Unidade: tonelada

Estabilizadores totalmente estendidos para 8m, contrapeso de 3t, sobre a área de trabalho lateral ou traseira															
RAIO DE TRABALHO (m)	Comprimento da lança da ponta: 3m, deslocamento: 30°												RAIO DE TRABALHO (m)		
	25,8	25,8	25,8	25,8	25,8	25,8 ★	30,0	30,0	30,0	30,0	30,0	30,0		30,0 ★	
3,0														3,0	
3,5														3,5	
4,0														4,0	
4,5														4,5	
5,0														5,0	
5,5	16,0	16,0	16,0	16,0	16,0	16,0								5,5	
6,0	15,0	15,0	16,0	16,0	16,0	16,0								6,0	
7,0	14,0	14,0	16,0	16,0	16,0	16,0	13,5	16,0	16,0	16,0	16,0	16,0	16,0	7,0	
8,0	13,0	13,0	16,0	16,0	16,0	16,0	12,2	15,0	16,0	16,0	16,0	16,0	16,0	8,0	
9,0	12,0	12,0	16,0	16,0	16,0	16,0	11,2	14,0	15,0	16,0	16,0	16,0	16,0	9,0	
10,0	11,0	11,0	16,0	16,0	16,0	16,0	10,2	13,0	14,0	16,0	16,0	16,0	16,0	10,0	
11,0	10,5	10,5	16,0	16,0	16,0	14,5	9,5	12,0	13,0	16,0	16,0	14,5	14,5	11,0	
12,0	10,0	10,0	16,0	15,0	14,1	13,9	9,0	11,0	12,0	15,0	14,0	12,8	12,8	12,0	
14,0	9,0	9,0	13,8	13,1	12,2	11,0	8,0	10,0	10,5	13,5	12,6	11,4	11,4	14,0	
16,0	8,0	8,0	10,7	10,0	9,1	7,9	7,0	9,0	9,5	10,6	9,7	8,5	8,5	16,0	
18,0	7,0	7,0	8,4	7,7	6,9	5,7	6,0	8,0	8,5	8,4	7,5	6,3	6,3	18,0	
20,0	6,5	6,5	6,7	6,0	5,2	4,0	5,5	7,1	6,9	6,7	5,8	4,6	4,6	20,0	
22,0	5,7	5,4	5,3	4,6	3,8	2,6	5,0	5,8	5,6	5,4	4,5	3,3	3,3	22,0	
24,0							4,5	4,7	4,5	4,3	3,5	2,3	2,3	24,0	
26,0							4,2	3,8	3,6	3,4	2,6	1,4	1,4	26,0	
28,0														28,0	
30,0														30,0	
32,0														32,0	
Passagem	3													Passagem	
Gancho	18t													Gancho	
Modo telescópico	I	1	1	1	1	1	2	1	1	1	1	1	2	I	Modo telescópico
	II	1	1	1	1	2	2	1	1	1	1	2	2	II	
	III	1	1	1	2	2	2	1	1	1	2	2	2	III	
	IV	1	1	2	2	2	1	1	2	3	2	2	2	IV	
	V	2	3	2	2	1	1	3	3	2	2	2	1	V	
	VI	3	2	2	1	1	1	3	2	2	2	1	1	VI	

Tabela 1-62 Tabela de capacidade de elevação (apenas com lança principal)

Unidade: tonelada

Estabilizadores totalmente estendidos para 8m, contrapeso de 3t, sobre a área de trabalho lateral ou traseira															
RAIO DE TRABALHO (m)	Comprimento da lança da ponta: 3m, deslocamento: 30°												RAIO DE TRABALHO (m)		
	34,2	34,2	34,2	34,2	34,2	34,2 ★	38,4	38,4	38,4	38,4	38,4	38,4		38,4 ★	
3,0														3,0	
3,5														3,5	
4,0														4,0	
4,5														4,5	
5,0														5,0	
5,5														5,5	
6,0														6,0	
7,0														7,0	
8,0	12,5	14,0	16,0	16,0	16,0	16,0								8,0	
9,0	11,5	13,0	16,0	16,0	16,0	16,0	12,0	14,0	16,0	16,0	16,0	16,0	16,0	9,0	
10,0	10,5	12,0	15,0	15,0	16,0	16,0	11,0	13,0	15,0	16,0	16,0	16,0	16,0	10,0	
11,0	10,0	11,0	14,0	14,0	16,0	15,0	10,0	12,0	14,0	16,0	16,0	16,0	16,0	11,0	
12,0	9,5	10,0	13,0	13,0	15,0	13,5	9,5	11,5	13,0	15,5	15,0	14,5	12,0	12,0	
14,0	8,5	9,0	12,0	12,0	13,0	11,8	8,1	10,0	11,0	13,5	13,1	12,7	14,0	14,0	
16,0	7,5	8,0	10,5	10,5	10,2	9,0	7,2	9,0	10,0	10,4	10,1	9,7	16,0	16,0	
18,0	6,5	7,0	8,5	8,3	8,0	6,9	6,3	8,0	8,5	8,1	7,8	7,4	18.	18.	
20,0	6,0	6,5	6,8	6,6	6,3	5,2	5,7	7,1	6,9	6,5	6,2	5,8	20.	20.	
22,0	5,5	5,8	5,4	5,2	4,9	3,8	5,1	5,8	5,6	5,2	4,9	4,5	22.	22.	
24,0	5,0	4,8	4,4	4,2	3,9	2,8	4,6	4,7	4,5	4,1	3,8	3,5	24.	24.	
26,0	4,2	4,0	3,6	3,4	3,1	2,0	4,2	3,8	3,6	3,2	2,9	2,6	26.	26.	
28,0	3,5	3,3	2,9	2,7	2,4	1,3	3,5	3,1	2,9	2,5	2,2	1,9	28.	28.	
30,0							2,9	2,5	2,3	1,9	1,6	1,3	30.	30.	
32,0													32.	32.	
Passagem Gancho	3												Passagem Gancho		
	18t														
Modo telescópico	I	1	1	1	1	1	2	1	1	1	1	1	2	I	Modo telescópico
	II	1	1	1	1	2	2	1	1	1	2	3	2	II	
	III	1	1	2	3	2	2	1	2	3	3	2	2	III	
	IV	2	3	3	2	2	2	3	3	3	2	2	2	IV	
	V	3	3	2	2	2	2	3	3	2	2	2	2	V	
	VI	3	2	2	2	2	1	3	2	2	2	2	2	VI	

Descrição do Guindaste

Tabela 1-63 Tabela de capacidade de elevação (apenas com lança principal)

Unidade: tonelada

Estabilizadores totalmente estendidos para 8m, contrapeso de 3t, sobre a área de trabalho lateral ou traseira															
RAIO DE TRABALHO (m)	Comprimento da lança da ponta: 3m, deslocamento: 30°											RAIO DE TRABALHO (m)			
	42,6	42,6	42,6	42,6	42,6	42,6★		46,8	46,8	46,8	46,8		46,8★		
3,0														3,0	
3,5														3,5	
4,0														4,0	
4,5														4,5	
5,0														5,0	
5,5														5,5	
6,0														6,0	
7,0														7,0	
8,0														8,0	
9,0														9,0	
10,0														10,0	
11,0	10,5	12,0	14,0	16,0	16,0	16,0		10,5	12,0	14,0	16,0	16,0	11,0		
12,0	10,0	11,0	13,0	15,0	14,5	14,5		9,5	11,0	13,0	14,5	14,0	12,0		
14,0	9,0	9,5	11,5	13,0	12,5	12,1		9,0	10,5	12,5	12,5	12,0	14,0		
16,0	8,0	8,5	10,0	10,2	9,7	9,3		8,0	9,5	10,5	9,7	9,2	16,0		
18,0	7,1	7,7	8,2	7,8	7,3	6,9		7,0	8,5	8,2	7,5	7,0	18,0		
20,0	6,4	7,1	6,6	6,2	5,7	5,3		6,5	6,9	6,4	5,7	5,2	20,0		
22,0	5,8	5,7	5,2	4,8	4,3	3,9		5,7	5,5	5,0	4,3	3,8	22,0		
24,0	5,2	4,8	4,3	3,9	3,4	3,0		5,1	4,5	4,0	3,3	2,8	24,0		
26,0	4,3	3,9	3,4	3,0	2,5	2,1		4,3	3,7	3,2	2,5	2,0	26,0		
28,0	3,5	3,1	2,6	2,2	1,7	1,4		3,5	2,9	2,5	1,8	1,3	28,0		
30,0														30,0	
32,0														32,0	
Passagem	3											Passagem			
Gancho	18t											Gancho			
Modo telescópico	I	1	1	1	1	2	3		1	1	1	2	3	I	Modo telescópico
	II	1	1	2	3	3	2		1	2	3	3	3	II	
	III	2	3	3	3	2	2		3	3	3	3	2	III	
	IV	3	3	3	2	2	2		3	3	3	2	2	IV	
	V	3	3	2	2	2	2		3	3	2	2	2	V	
	VI	3	2	2	2	2	2		3	2	2	2	2	VI	

Tabela 1-64 Tabela de capacidade de elevação (apenas com lança principal)

Unidade: tonelada

Estabilizadores totalmente estendidos para 8m, contrapeso de 3t, sobre a área de trabalho lateral ou traseira														
RAIO DE TRABALHO (m)	Comprimento da lança da ponta: 3m, deslocamento: 30°												RAIO DE TRABALHO (m)	
	51,0	51,0	51,0	51,0 ★	55,2	55,2	55,2 ★		59,4	59,4 ★	63,6 ★	70,0 ★		
4,0														4,0
4,5														4,5
5,0														5,0
5,5														5,5
6,0														6,0
7,0														7,0
8,0														8,0
9,0														9,0
10,0														10,0
11,0														11,0
12,0														12,0
14,0	9,5	11,0	12,5	12,0	9,5	11,0	11,5							14,0
16,0	8,5	10,0	10,0	9,2	8,7	10,0	9,2		9,0	9,5				16,0
18,0	7,5	8,5	7,7	7,0	8,1	8,2	7,4		8,0	7,2	7,5			18,0
20,0	7,0	6,8	6,0	5,4	7,2	6,5	5,7		6,8	6,0	6,0	6,0		20,0
22,0	6,0	5,5	4,7	4,1	5,9	5,1	4,4		5,5	4,7	4,9	5,0		22,0
24,0	4,9	4,4	3,6	3,0	4,8	4,0	3,3		4,4	3,6	3,9	4,0		24,0
26,0	4,0	3,5	2,7	2,1	3,9	3,1	2,4		3,5	2,7	3,1	3,2		26,0
28,0	3,3	2,8	2,0	1,4	3,1	2,3	1,6		2,7	2,0	2,3	2,4		28,0
30,0					2,5	1,7	1,0		2,1	1,4	1,7	1,8		30,0
32,0											1,2	1,3		32,0
Passagem	3						2						Passagem	
Gancho	18t												Gancho	
Modo telescópico	I	1	1	2	3	1	2	3		2	3	3	4	I
	II	2	3	3	3	3	3	3		3	3	3	4	II
	III	3	3	3	3	3	3	3		3	3	3	4	III
	IV	3	3	3	2	3	3	3		3	3	3	4	IV
	V	3	3	2	2	3	3	2		3	3	3	4	V
	VI	3	2	2	2	3	2	2		3	2	3	4	VI

Descrição do Guindaste

Tabela 1-65 Tabela de capacidade de elevação (apenas com lança principal)

Unidade: tonelada

Estabilizadores totalmente estendidos para 5,3m, contrapeso de 34t, sobre a área de trabalho lateral ou traseira														
RAIO DE TRABALHO (m)	Comprimento de lança (m)												RAIO DE TRABALHO (m)	
	13,2 ★	17,4	17,4	17,4	17,4	17,4 ★	21,6	21,6	21,6	21,6	21,6	21,6 ★		
3,0	70,0	40,0	65,0	65,0	65,0	65,0	29,5	40,0	60,0	60,0	60,0	60,0	3,0	
3,5	67,0	37,0	60,0	60,0	60,0	60,0	28,0	38,0	56,0	60,0	60,0	60,0	3,5	
4,0	64,0	35,0	56,5	57,0	57,0	57,0	26,0	36,0	53,0	60,0	60,0	60,0	4,0	
4,5	60,0	33,0	52,5	54,0	54,0	54,0	24,0	34,0	50,0	60,0	60,0	60,0	4,5	
5,0	58,0	31,5	49,0	52,0	52,0	51,0	23,0	33,0	48,0	56,0	60,0	60,0	5,0	
5,5	56,0	30,0	46,0	49,0	49,0	48,0	22,0	31,5	46,0	52,0	58,0	58,0	5,5	
6,0	48,0	28,5	43,0	46,0	46,0	45,0	21,0	30,0	43,0	48,0	52,0	51,0	6,0	
7,0	40,0	27,0	38,5	44,0	43,0	42,0	19,0	28,0	38,5	45,0	45,0	44,0	7,0	
8,0	34,0	25,5	35,0	39,0	38,0	37,0	17,0	26,0	35,0	40,0	39,0	38,0	8,0	
9,0	28,0	24,0	32,0	33,5	33,0	32,0	16,0	23,5	32,0	34,0	33,0	32,0	9,0	
10,0		22,5	28,5	28,0	27,5	27,0	15,0	22,0	29,0	28,5	28,0	27,0	10,0	
11,0		21,5	24,5	24,0	23,5	23,0	13,9	20,5	25,0	24,5	24,0	23,0	11,0	
12,0		20,3	21,5	21,0	20,5	20,0	13,0	19,0	22,0	21,5	20,0	19,0	12,0	
14,0							11,5	17,0	17,5	17,0	15,5	14,5	14,0	
16,0							10,4	15,0	14,0	13,5	12,5	11,5	16,0	
18,0													18,0	
20,0													20,0	
22,0													22,0	
24,0													24,0	
26,0													26,0	
28,0													28,0	
30,0													30,0	
32,0													32,0	
34,0													34,0	
36,0													36,0	
38,0													38,0	
40,0													40,0	
42,0													42,0	
44,0													44,0	
46,0													46,0	
Passagem	12	12						12						Passagem
Gancho	60t													Gancho
Modo telescópico	I	1	1	1	1	1	1	1	1	1	1	1	2	I
	II	1	1	1	1	1	2	1	1	1	1	2	2	II
	III	1	1	1	1	2	1	1	1	1	2	2	1	III
	IV	1	1	1	2	1	1	1	1	2	2	1	1	IV
	V	1	1	2	1	1	1	1	2	2	1	1	1	V
	VI	1	2	1	1	1	1	3	2	1	1	1	1	VI

Tabela 1-66 Tabela de capacidade de elevação (apenas com lança principal)

Unidade: tonelada

Estabilizadores totalmente estendidos para 5,3m, contrapeso de 34t, sobre a área de trabalho lateral ou traseira															
RAIO DE TRABALHO (m)	Comprimento de lança (m)												RAIO DE TRABALHO (m)		
	25,8	25,8	25,8	25,8	25,8	25,8 ★	30,0	30,0	30,0	30,0	30,0	30,0		30,0 ★	
3,0														3,0	
3,5														3,5	
4,0	25,0	25,0	43,0	55,0	55,0	55,0								4,0	
4,5	23,5	23,5	41,0	53,0	55,0	55,0								4,5	
5,0	22,0	22,0	39,5	51,0	53,0	53,0	19,0	24,0	26,0	42,0	50,0	50,0		5,0	
5,5	21,0	21,0	38,0	49,0	51,0	51,0	18,5	23,0	24,5	40,5	48,0	48,0		5,5	
6,0	20,0	20,0	36,0	47,0	48,0	48,0	17,5	22,0	23,0	39,5	47,0	46,0		6,0	
7,0	18,0	18,0	33,0	42,0	45,0	45,0	15,8	20,0	21,0	36,0	44,0	43,0		7,0	
8,0	16,5	16,5	30,0	38,0	40,0	40,0	14,3	18,5	19,0	33,5	41,0	40,0		8,0	
9,0	15,0	15,0	28,0	34,5	34,0	33,0	13,0	17,0	17,5	31,0	34,0	33,5		9,0	
10,0	14,0	14,0	26,0	29,5	28,5	27,5	12,0	15,5	16,0	28,5	29,0	28,5		10,0	
11,0	13,0	13,0	24,5	25,0	24,5	23,5	11,0	14,5	15,0	27,0	25,0	24,5		11,0	
12,0	12,0	12,0	22,5	21,5	21,0	20,0	10,3	13,5	14,0	24,0	22,5	21,5		12,0	
14,0	10,5	10,5	18,5	18,0	17,0	16,0	9,0	11,9	12,2	19,0	18,0	16,5		14,0	
16,0	9,4	9,3	15,0	14,5	13,5	12,0	8,0	10,7	10,7	15,0	14,0	13,0		16,0	
18,0	8,5	8,4	12,5	12,0	11,0	9,5	7,1	9,6	9,6	12,8	11,5	10,5		18,0	
20,0	7,7	7,6	10,5	10,0	9,0	7,8	6,4	8,7	8,7	10,8	9,8	8,6		20,0	
22,0							5,8	8,0	7,9	9,3	8,3	7,1		22,0	
24,0							5,3	7,3	7,2	7,9	6,9	5,7		24,0	
26,0														26,0	
28,0														28,0	
30,0														30,0	
32,0														32,0	
34,0														34,0	
36,0														36,0	
38,0														38,0	
40,0														40,0	
42,0														42,0	
44,0														44,0	
46,0														46,0	
Passagem	11						9						Passagem		
Gancho	60t												Gancho		
Modo telescópico	I	1	1	1	1	1	2	1	1	1	1	1	2	I	Modo telescópico
	II	1	1	1	1	2	2	1	1	1	1	2	2	II	
	III	1	1	1	2	2	2	1	1	1	2	2	2	III	
	IV	1	1	2	2	2	1	1	2	3	2	2	2	IV	
	V	2	3	2	2	1	1	3	3	2	2	2	1	V	
	VI	3	2	2	1	1	1	3	2	2	2	1	1	VI	

Descrição do Guindaste

Tabela 1-67 Tabela de capacidade de elevação (apenas com lança principal)

Unidade: tonelada

Estabilizadores totalmente estendidos para 5,3m, contrapeso de 34t, sobre a área de trabalho lateral ou traseira														
RAIO DE TRABALHO (m)	Comprimento de lança (m)												RAIO DE TRABALHO (m)	
	34,2	34,2	34,2	34,2	34,2	34,2 ★	38,4	38,4	38,4	38,4	38,4	38,4		38,4 ★
3,0														3,0
3,5														3,5
4,0														4,0
4,5														4,5
5,0														5,0
5,5														5,5
6,0	19,0	21,5	25,5	26,0	43,0	46,0								6,0
7,0	17,0	19,0	23,0	23,5	40,5	44,0	17,0	20,0	21,5	26,0	30,5	41,5		7,0
8,0	15,5	17,5	21,0	21,5	38,0	40,0	15,5	18,5	19,5	24,0	28,0	39,0		8,0
9,0	14,5	16,0	19,5	19,5	35,0	35,0	14,0	17,0	18,0	22,0	25,5	36,0		9,0
10,0	13,3	14,5	18,0	18,0	30,5	30,0	13,0	15,7	16,5	20,3	23,5	30,0		10,0
11,0	12,3	13,5	16,5	16,5	27,5	26,0	12,0	14,5	15,2	18,8	22,0	26,5		11,0
12,0	11,5	12,5	15,5	15,5	24,0	22,5	11,0	13,5	14,0	17,5	20,5	23,0		12,0
14,0	10,1	10,8	13,5	13,5	19,0	17,5	9,5	11,7	12,2	15,4	17,7	18,5		14,0
16,0	8,9	9,6	11,8	11,8	15,5	14,0	8,5	10,4	10,8	13,6	15,2	14,7		16,0
18,0	8,0	8,5	10,5	10,5	12,6	11,2	7,5	9,3	9,6	12,1	12,4	12,0		18,0
20,0	7,2	7,7	9,5	9,4	10,5	9,2	6,7	8,4	8,6	10,7	10,4	10,0		20,0
22,0	6,5	6,9	8,6	8,5	9,0	7,6	6,0	7,6	7,7	9,0	8,8	8,4		22,0
24,0	6,0	6,3	7,9	7,8	7,6	6,3	5,5	6,9	7,0	7,7	7,5	7,1		24,0
26,0	5,5	5,7	6,9	6,8	6,5	5,2	5,0	6,3	6,3	6,6	6,4	6,0		26,0
28,0	5,1	5,3	6,0	5,9	5,6	4,3	4,5	5,8	5,8	5,6	5,4	5,0		28,0
30,0							4,2	5,3	5,3	4,8	4,6	4,2		30,0
32,0							3,9	4,8	4,5	4,1	3,9	3,5		32,0
34,0														34,0
36,0														36,0
38,0														38,0
40,0														40,0
42,0														42,0
44,0														44,0
46,0														46,0
Passagem	8						7						Passagem	
Gancho	60t												Gancho	
Modo telescópico	I	1	1	1	1	1	2	1	1	1	1	1	2	I
	II	1	1	1	1	2	2	1	1	1	2	3	2	II
	III	1	1	2	3	2	2	1	2	3	3	2	2	III
	IV	2	3	3	2	2	2	3	3	3	2	2	2	IV
	V	3	3	2	2	2	2	3	3	2	2	2	2	V
	VI	3	2	2	2	2	1	3	2	2	2	2	2	VI
														Modo telescópico

Tabela 1-68 Tabela de capacidade de elevação (apenas com lança principal)

Unidade: tonelada

Estabilizadores totalmente estendidos para 5,3m, contrapeso de 34t, sobre a área de trabalho lateral ou traseira														
RAIO DE TRABALHO (m)	Comprimento de lança (m)												RAIO DE TRABALHO (m)	
	42,6	42,6	42,6	42,6	42,6	42,6 ★		46,8	46,8	46,8	46,8	46,8 ★		
3,0														3,0
3,5														3,5
4,0														4,0
4,5														4,5
5,0														5,0
5,5														5,5
6,0														6,0
7,0														7,0
8,0	16,5	18,0	21,5	26,0	30,0	32,5								8,0
9,0	15,0	16,5	20,0	24,0	28,0	30,0								9,0
10,0	14,0	15,0	18,5	22,0	26,0	28,0		14,0	16,5	19,5	23,0	25,0		10,0
11,0	12,9	14,0	17,0	20,3	24,0	26,0		12,8	15,3	18,0	21,3	23,5		11,0
12,0	12,0	12,9	15,8	18,8	22,3	23,2		11,9	14,2	16,8	19,8	22,0		12,0
14,0	10,4	11,0	13,8	16,3	18,4	18,0		10,3	12,3	14,6	17,4	18,0		14,0
16,0	9,2	9,8	12,2	14,4	14,7	14,3		9,0	10,9	13,0	14,8	14,3		16,0
18,0	8,2	8,6	10,8	12,6	12,0	11,6		8,0	9,6	11,5	12,1	11,5		18,0
20,0	7,3	7,7	9,7	10,5	9,9	9,5		7,1	8,6	10,2	10,0	9,5		20,0
22,0	6,6	6,9	8,7	8,9	8,3	7,9		6,4	7,7	9,0	8,4	7,8		22,0
24,0	6,0	6,2	7,9	7,5	6,9	6,6		5,7	7,0	7,7	7,0	6,5		24,0
26,0	5,5	5,6	6,8	6,4	5,8	5,5		5,2	6,4	6,6	5,9	5,3		26,0
28,0	5,0	5,1	5,8	5,5	4,9	4,5		4,7	5,8	5,6	5,0	4,4		28,0
30,0	4,6	4,7	5,0	4,7	4,1	3,7		4,3	5,2	4,8	4,2	3,7		30,0
32,0	4,3	4,3	4,3	4,0	3,4	3,0		4,0	4,5	4,2	3,5	3,0		32,0
34,0	4,0	3,9	3,7	3,4	2,8	2,4		3,6	4,0	3,6	2,9	2,4		34,0
36,0	3,7	3,6	3,2	2,8	2,2	1,9		3,3	3,5	3,0	2,3	1,8		36,0
38,0								3,0	3,0	2,5	1,9	1,4		38,0
40,0								2,8	2,5	2,0	1,4	1,0		40,0
42,0														42,0
44,0														44,0
46,0														46,0
Passagem	6						5						Passagem	
Gancho	60t												Gancho	
Modo telescópico	I	1	1	1	1	2	3		1	1	1	2	3	I
	II	1	1	2	3	3	2		1	2	3	3	3	II
	III	2	3	3	3	2	2		3	3	3	3	2	III
	IV	3	3	3	2	2	2		3	3	3	2	2	IV
	V	3	3	2	2	2	2		3	3	2	2	2	V
	VI	3	2	2	2	2	2		3	2	2	2	2	VI

Descrição do Guindaste

Tabela 1-69 Tabela de capacidade de elevação (apenas com lança principal)

Unidade: tonelada

Estabilizadores totalmente estendidos para 5,3m, contrapeso de 34t, sobre a área de trabalho lateral ou traseira														
RAIO DE TRABALHO (m)	Comprimento de lança (m)												RAIO DE TRABALHO (m)	
	51,0	51,0	51,0	51,0 ★	55,2	55,2	55,2 ★		59,4	59,4 ★	63,6 ★	70,0 ★		
3,0														3,0
3,5														3,5
4,0														4,0
4,5														4,5
5,0														5,0
5,5														5,5
6,0														6,0
7,0														7,0
8,0														8,0
9,0														9,0
10,0														10,0
11,0	13,5	15,5	18,0	20,0										11,0
12,0	13,0	14,5	17,0	19,5	13,0	14,0	15,5							12,0
14,0	11,3	13,0	15,5	17,5	11,5	13,0	14,5		11,0	12,0				14,0
16,0	10,0	11,5	13,8	14,5	10,5	12,0	13,5		10,5	11,5	9,5			16,0
18,0	9,0	10,4	12,4	11,7	9,5	11,0	12,0		9,6	11,0	9,2	7,0		18,0
20,0	8,0	9,3	10,3	9,6	8,5	9,8	10,0		9,0	10,2	9,0	7,0		20,0
22,0	7,2	8,4	8,6	8,0	7,8	9,0	8,3		8,2	8,6	8,4	6,8		22,0
24,0	6,5	7,6	7,2	6,6	7,0	7,6	6,9		7,5	7,2	7,6	6,5		24,0
26,0	6,0	6,9	6,1	5,5	6,4	6,5	5,8		6,9	6,1	6,5	6,2		26,0
28,0	5,5	5,9	5,2	4,5	5,9	5,5	4,9		5,9	5,2	5,5	5,6		28,0
30,0	5,0	5,0	4,4	3,8	5,4	4,7	4,1		5,1	4,4	4,6	4,8		30,0
32,0	4,5	4,4	3,7	3,1	4,7	4,0	3,3		4,4	3,6	4,0	4,1		32,0
34,0	4,2	3,8	3,1	2,5	4,0	3,4	2,7		3,8	3,0	3,4	3,5		34,0
36,0	3,7	3,2	2,6	2,0	3,5	2,9	2,2		3,2	2,5	2,9	3,0		36,0
38,0	3,2	2,8	2,1	1,5	3,1	2,4	1,7		2,7	2,0	2,4	2,5		38,0
40,0	2,8	2,4	1,7	1,1	2,7	2,0	1,3		2,3	1,6	2,0	2,1		40,0
42,0					2,3	1,6	0,9		1,9	1,2	1,6	1,7		42,0
44,0									1,6	0,9	1,2	1,3		44,0
46,0											0,9	1,0		46,0
Passagem	4				3				3			3	3	Passagem
Gancho	60t												Gancho	
Modo telescópico	I	1	1	2	3	1	2	3		2	3	3	4	I
	II	2	3	3	3	3	3	3		3	3	3	4	II
	III	3	3	3	3	3	3	3		3	3	3	4	III
	IV	3	3	3	2	3	3	3		3	3	3	4	IV
	V	3	3	2	2	3	3	2		3	3	3	4	V
	VI	3	2	2	2	3	2	2		3	2	3	4	VI
														Modo telescópico

Tabela 1-70 Tabela de capacidade de elevação (apenas com lança principal)

Unidade: tonelada

Estabilizadores totalmente estendidos para 5,3m, contrapeso de 23t, sobre a área de trabalho lateral ou traseira														
RAIO DE TRABALHO (m)	Comprimento de lança (m)												RAIO DE TRABALHO (m)	
	13,2 ★	17,4	17,4	17,4	17,4	17,4 ★	21,6	21,6	21,6	21,6	21,6	21,6 ★		
3,0	70,0	40,0	65,0	65,0	65,0	65,0	29,5	40,0	60,0	60,0	60,0	60,0	3,0	
3,5	67,0	37,0	60,0	60,0	60,0	60,0	28,0	38,0	56,0	60,0	60,0	60,0	3,5	
4,0	64,0	35,0	56,5	57,0	57,0	57,0	26,0	36,0	53,0	60,0	60,0	60,0	4,0	
4,5	60,0	33,0	52,5	54,0	54,0	54,0	24,0	34,0	50,0	60,0	60,0	60,0	4,5	
5,0	56,0	31,5	49,0	52,0	52,0	51,0	23,0	33,0	48,0	55,0	55,0	54,0	5,0	
5,5	52,0	30,0	46,0	48,0	49,0	48,0	22,0	31,5	46,0	49,0	49,0	48,0	5,5	
6,0	44,0	28,5	43,0	45,0	46,0	45,0	21,0	30,0	43,0	45,0	45,0	44,0	6,0	
7,0	36,0	27,0	38,5	42,0	41,0	40,0	19,0	28,0	38,5	39,0	38,0	37,0	7,0	
8,0	31,0	25,5	34,0	33,5	33,0	32,5	17,0	26,0	34,0	33,5	32,5	31,5	8,0	
9,0	25,0	24,0	27,5	27,0	26,5	26,0	16,0	23,5	28,0	27,5	26,5	25,5	9,0	
10,0		22,5	23,5	23,0	22,5	22,0	15,0	22,0	23,5	23,0	22,0	21,0	10,0	
11,0		20,5	20,0	19,5	19,0	18,5	13,9	20,5	20,5	20,0	19,0	17,5	11,0	
12,0		17,5	17,0	16,5	16,0	15,5	13,0	18,5	18,0	17,5	16,5	15,0	12,0	
14,0							11,5	14,0	13,5	13,0	12,0	11,0	14,0	
16,0							10,4	11,0	10,5	10,0	9,0	8,0	16,0	
18,0													18,0	
20,0													20,0	
22,0													22,0	
24,0													24,0	
26,0													26,0	
28,0													28,0	
30,0													30,0	
32,0													32,0	
34,0													34,0	
36,0													36,0	
38,0													38,0	
Passagem	12	12					12					Passagem		
Gancho	60t												Gancho	
Modo telescópico	I	1	1	1	1	1	1	1	1	1	1	1	2	Modo telescópico
	II	1	1	1	1	1	2	1	1	1	1	2	2	
	III	1	1	1	1	2	1	1	1	1	2	2	1	
	IV	1	1	1	2	1	1	1	1	2	2	1	1	
	V	1	1	2	1	1	1	1	2	2	1	1	1	
	VI	1	2	1	1	1	1	3	2	1	1	1	1	

Descrição do Guindaste

Tabela 1-71 Tabela de capacidade de elevação (apenas com lança principal)

Unidade: tonelada

Estabilizadores totalmente estendidos para 5,3m, contrapeso de 23t, sobre a área de trabalho lateral ou traseira															
RAIO DE TRABALHO (m)	Comprimento de lança (m)												RAIO DE TRABALHO (m)		
	25,8	25,8	25,8	25,8	25,8	25,8 ★	30,0	30,0	30,0	30,0	30,0	30,0		30,0 ★	
3,0														3,0	
3,5														3,5	
4,0	25,0	25,0	43,0	55,0	55,0	55,0								4,0	
4,5	23,5	23,5	41,0	53,0	55,0	55,0								4,5	
5,0	22,0	22,0	39,5	51,0	53,0	53,0	19,0	24,0	26,0	42,0	50,0	50,0	50,0	5,0	
5,5	21,0	21,0	38,0	49,0	51,0	50,0	18,0	23,0	24,5	40,5	48,0	48,0	48,0	5,5	
6,0	20,0	20,0	36,0	47,0	46,0	45,0	17,5	22,0	23,0	39,5	47,0	45,0	45,0	6,0	
7,0	18,0	18,0	33,0	42,0	40,0	39,0	15,8	20,0	21,0	36,0	42,0	41,0	41,0	7,0	
8,0	16,5	16,5	30,0	35,0	34,0	33,0	14,3	18,5	19,0	33,5	34,0	33,0	33,0	8,0	
9,0	15,0	15,0	28,0	28,5	27,5	26,5	13,0	17,0	17,5	29,0	28,0	27,0	27,0	9,0	
10,0	14,0	14,0	25,0	24,0	23,0	22,0	12,0	15,5	16,0	24,5	23,5	22,5	22,5	10,0	
11,0	13,0	13,0	21,5	20,5	19,5	18,5	11,0	14,5	15,0	21,0	20,0	19,0	19,0	11,0	
12,0	12,1	12,1	19,0	18,0	17,0	15,5	10,3	13,5	14,0	18,5	17,5	16,5	16,5	12,0	
14,0	10,5	10,5	14,5	14,0	13,0	11,5	9,0	11,9	12,0	14,5	13,5	12,5	12,5	14,0	
16,0	9,4	9,3	11,5	11,0	10,1	8,8	8,0	10,7	10,6	11,5	10,5	9,5	9,5	16,0	
18,0	8,5	8,4	9,5	8,9	8,0	6,7	7,0	9,6	9,5	9,5	8,6	7,3	7,3	18,0	
20,0	7,7	7,6	8,0	7,2	6,3	5,0	6,3	8,3	8,1	7,9	7,0	5,7	5,7	20,0	
22,0							5,8	7,0	6,8	6,6	5,7	4,4	4,4	22,0	
24,0							5,3	5,9	5,7	5,5	4,6	3,3	3,3	24,0	
26,0														26,0	
28,0														28,0	
30,0														30,0	
32,0														32,0	
34,0														34,0	
36,0														36,0	
38,0														38,0	
Passagem Gancho	11						9						Passagem Gancho		
Modo telescópico	60t														Modo telescópico
I	1	1	1	1	1	2	1	1	1	1	1	2	I		
II	1	1	1	1	2	2	1	1	1	1	2	2	II		
III	1	1	1	2	2	2	1	1	1	2	2	2	III		
IV	1	1	2	2	2	1	1	2	3	2	2	2	IV		
V	2	3	2	2	1	1	3	3	2	2	2	1	V		
VI	3	2	2	1	1	1	3	2	2	2	1	1	VI		

Tabela 1-72 Tabela de capacidade de elevação (apenas com lança principal)

Unidade: tonelada

Estabilizadores totalmente estendidos para 5,3m, contrapeso de 23t, sobre a área de trabalho lateral ou traseira															
RAIO DE TRABALHO (m)	Comprimento de lança (m)												RAIO DE TRABALHO (m)		
	34,2	34,2	34,2	34,2	34,2	34,2 ★	38,4	38,4	38,4	38,4	38,4	38,4 ★			
3,0														3,0	
3,5														3,5	
4,0														4,0	
4,5														4,5	
5,0														5,0	
5,5														5,5	
6,0	19,0	21,5	25,5	26,0	43,0	46,0								6,0	
7,0	17,0	19,0	23,0	23,5	40,5	41,0	17,0	20,0	21,5	26,0	30,5	41,5		7,0	
8,0	15,5	17,5	21,0	21,5	35,5	34,0	15,5	18,5	19,5	24,0	28,0	34,0		8,0	
9,0	14,5	16,0	19,5	19,5	29,5	28,0	14,0	17,0	18,0	22,0	25,5	28,5		9,0	
10,0	13,3	14,5	18,0	18,0	25,0	23,5	13,0	15,7	16,5	20,3	23,5	24,0		10,0	
11,0	12,3	13,5	16,5	16,5	21,5	20,0	12,0	14,5	15,2	18,8	21,5	20,5		11,0	
12,0	11,5	12,5	15,5	15,5	18,5	17,3	11,0	13,5	14,0	17,5	18,5	18,0		12,0	
14,0	10,1	10,8	13,5	13,5	14,5	13,3	9,5	11,7	12,2	14,6	14,3	13,8		14,0	
16,0	8,9	9,6	11,8	11,8	11,5	10,3	8,5	10,4	10,8	11,5	11,2	10,8		16,0	
18,0	8,0	8,5	9,8	9,6	9,3	8,1	7,5	9,3	9,6	9,5	9,2	8,8		18,0	
20,0	7,2	7,7	8,2	8,0	7,7	6,4	6,7	8,4	8,0	7,8	7,5	7,1		20,0	
22,0	6,5	6,9	6,8	6,6	6,3	5,1	6,0	7,2	6,8	6,4	6,1	5,7		22,0	
24,0	6,0	6,1	5,7	5,5	5,2	4,0	5,5	6,0	5,7	5,3	5,0	4,6		24,0	
26,0	5,5	5,2	4,8	4,6	4,3	3,1	5,0	5,1	4,8	4,4	4,2	3,8		26,0	
28,0	4,7	4,4	4,0	3,8	3,5	2,3	4,5	4,3	4,0	3,6	3,4	3,0		28,0	
30,0							4,0	3,7	3,3	2,9	2,7	2,3		30,0	
32,0							3,5	3,2	2,8	2,4	2,2	1,8		32,0	
34,0														34,0	
36,0														36,0	
38,0														38,0	
Passagem	8						7						Passagem		
Gancho	60t												Gancho		
Modo telescópico	I	1	1	1	1	1	2	1	1	1	1	2	I	Modo telescópico modo	
	II	1	1	1	1	2	2	1	1	1	2	2	II		
	III	1	1	2	3	2	2	1	2	3	3	2	2		III
	IV	2	3	3	2	2	2	3	3	3	2	2	2		IV
	V	3	3	2	2	2	2	3	3	2	2	2	2		V
	VI	3	2	2	2	2	1	3	2	2	2	2	2		VI

Descrição do Guindaste

Tabela 1-73 Tabela de capacidade de elevação (apenas com lança principal)

Unidade: tonelada

Estabilizadores totalmente estendidos para 5,3m, contrapeso de 23t, sobre a área de trabalho lateral ou traseira															
RAIO DE TRABALHO (m)	Comprimento de lança (m)												RAIO DE TRABALHO (m)		
	42,6	42,6	42,6	42,6	42,6	42,6★		46,8	46,8	46,8	46,8	46,8★			
3,0														3,0	
3,5														3,5	
4,0														4,0	
4,5														4,5	
5,0														5,0	
5,5														5,5	
6,0														6,0	
7,0														7,0	
8,0	16,5	18,0	21,5	26,0	30,0	32,5								8,0	
9,0	15,0	16,5	20,0	24,0	27,5	27,5								9,0	
10,0	14,0	15,0	18,5	22,0	24,0	23,0		14,0	16,5	19,5	22,5	23,0		10,0	
11,0	12,9	14,0	17,0	20,3	20,5	20,0		12,8	15,3	18,0	20,5	20,0		11,0	
12,0	12,0	12,9	15,8	18,8	18,0	17,5		11,9	14,2	16,8	18,0	17,5		12,0	
14,0	10,4	11,0	13,8	14,0	13,5	13,0		10,3	12,3	14,6	14,0	13,5		14,0	
16,0	9,2	9,8	11,8	11,4	10,9	10,5		9,0	10,9	11,7	11,0	10,5		16,0	
18,0	8,2	8,6	9,6	9,2	8,7	8,3		8,0	9,6	9,5	8,8	8,3		18,0	
20,0	7,3	7,7	8,0	7,6	7,0	6,6		7,1	8,3	7,8	7,1	6,6		20,0	
22,0	6,6	6,9	6,6	6,2	5,6	5,2		6,4	6,9	6,4	5,7	5,2		22,0	
24,0	6,0	6,0	5,5	5,1	4,5	4,1		5,7	5,8	5,3	4,6	4,1		24,0	
26,0	5,5	5,1	4,6	4,2	3,6	3,2		5,2	5,0	4,5	3,8	3,3		26,0	
28,0	4,7	4,3	3,8	3,5	2,9	2,5		4,6	4,1	3,6	2,9	2,4		28,0	
30,0	4,0	3,6	3,1	2,8	2,2	1,8		4,0	3,5	3,0	2,3	1,8		30,0	
32,0	3,5	3,1	2,6	2,3	1,7	1,3		3,4	2,9	2,5	1,8	1,3		32,0	
34,0	3,0	2,6	2,1	1,8	1,2	0,8		2,9	2,4	2,0	1,3	0,8		34,0	
36,0														36,0	
38,0														38,0	
Passagem	6							5						Passagem	
Gancho	60t												Gancho		
Modo telescópico	I	1	1	1	1	2	3		1	1	1	2	3	I	Modo telescópico
	II	1	1	2	3	3	2		1	2	3	3	3	II	
	III	2	3	3	3	2	2		3	3	3	3	2	III	
	IV	3	3	3	2	2	2		3	3	3	2	2	IV	
	V	3	3	2	2	2	2		3	3	2	2	2	V	
	VI	3	2	2	2	2	2		3	2	2	2	2	VI	

Tabela 1-74 Tabela de capacidade de elevação (apenas com lança principal)

Unidade: tonelada

Estabilizadores totalmente estendidos para 5,3m, contrapeso de 23t, sobre a área de trabalho lateral ou traseira														
RAIO DE TRABALHO (m)	Comprimento de lança (m)												RAIO DE TRABALHO (m)	
	51,0	51,0	51,0	51,0 ★	55,2	55,2	55,2 ★		59,4	59,4 ★	63,6 ★	70,0 ★		
3,0														3,0
3,5														3,5
4,0														4,0
4,5														4,5
5,0														5,0
5,5														5,5
6,0														6,0
7,0														7,0
8,0														8,0
9,0														9,0
10,0														10,0
11,0	13,5	15,5	18,0	19,0										11,0
12,0	13,0	14,5	17,0	17,5	13,0	14,0	15,5							12,0
14,0	11,3	13,0	14,0	13,3	11,5	13,0	13,5		11,0	12,0				14,0
16,0	10,0	11,5	11,3	10,6	10,5	11,0	10,8		10,5	11,0	9,5			16,0
18,0	9,0	9,8	9,0	8,4	9,5	9,5	8,8		9,6	8,8	8,5	7,0		18,0
20,0	8,0	8,2	7,4	6,8	8,5	7,8	7,1		8,0	7,2	7,5	6,8		20,0
22,0	7,2	6,8	6,0	5,4	7,1	6,4	5,7		6,6	5,8	6,3	6,0		22,0
24,0	6,2	5,7	4,9	4,3	6,0	5,3	4,6		5,6	4,8	5,2	5,0		24,0
26,0	5,3	4,8	4,0	3,4	5,0	4,3	3,7		4,7	4,0	4,3	4,4		26,0
28,0	4,5	4,0	3,3	2,7	4,3	3,6	2,9		3,9	3,2	3,5	3,6		28,0
30,0	3,8	3,3	2,6	2,0	3,6	2,9	2,2		3,2	2,5	2,8	2,9		30,0
32,0	3,2	2,7	2,0	1,4	3,1	2,4	1,7		2,7	2,0	2,3	2,4		32,0
34,0	2,8	2,3	1,5	0,9	2,6	1,9	1,2		2,2	1,5	1,8	1,9		34,0
36,0									1,8	1,1	1,4	1,5		36,0
38,0											1,0	1,1		38,0
Passagem	4				3				3			3	3	Passagem
Gancho	60t												Gancho	
Modo telescópico	I	1	1	2	3	1	2	3		2	3	3	4	I
	II	2	3	3	3	3	3	3		3	3	3	4	II
	III	3	3	3	3	3	3	3		3	3	3	4	III
	IV	3	3	3	2	3	3	3		3	3	3	4	IV
	V	3	3	2	2	3	3	2		3	3	3	4	V
	VI	3	2	2	2	3	2	2		3	2	3	4	VI

Descrição do Guindaste

Tabela 1-75 Tabela de capacidade de elevação (apenas com lança principal)

Unidade: tonelada

Estabilizadores totalmente estendidos para 5,3m, contrapeso de 19t, sobre a área de trabalho lateral ou traseira														
RAIO DE TRABALHO (m)	Comprimento de lança (m)												RAIO DE TRABALHO (m)	
	13,2 ★	17,4	17,4	17,4	17,4	17,4 ★	21,6	21,6	21,6	21,6	21,6	21,6 ★		
3,0	70,0	40,0	65,0	65,0	65,0	65,0	29,5	40,0	60,0	60,0	60,0	60,0	3,0	
3,5	67,0	37,0	60,0	60,0	60,0	60,0	27,5	38,0	56,0	60,0	60,0	60,0	3,5	
4,0	64,0	35,0	56,5	57,0	57,0	57,0	26,0	36,0	53,0	60,0	60,0	60,0	4,0	
4,5	60,0	33,0	52,5	54,0	54,0	53,0	24,0	34,0	50,0	57,0	57,0	57,0	4,5	
5,0	56,0	31,5	49,0	52,0	50,0	49,0	23,0	33,0	48,0	55,0	55,0	54,0	5,0	
5,5	51,0	30,0	46,0	47,0	46,0	45,0	22,0	31,5	45,5	49,0	49,0	48,0	5,5	
6,0	44,0	28,5	43,0	43,0	42,0	41,0	21,0	30,0	43,0	44,0	43,0	42,0	6,0	
7,0	35,0	27,0	38,5	39,0	38,0	37,0	19,0	28,0	38,5	38,0	37,0	36,0	7,0	
8,0	28,0	25,5	31,0	30,5	30,0	29,0	17,0	26,0	31,5	30,0	29,0	28,0	8,0	
9,0	23,0	24,0	25,0	24,5	24,0	23,5	16,0	23,5	25,5	25,0	24,0	22,5	9,0	
10,0		21,5	21,2	20,7	20,2	19,7	15,0	22,0	21,5	21,0	20,0	18,5	10,0	
11,0		18,2	17,9	17,4	16,9	16,4	13,9	19,0	18,5	17,5	16,7	15,5	11,0	
12,0		15,5	15,2	14,7	14,2	13,7	13,0	16,6	16,2	15,2	14,4	13,2	12,0	
14,0							11,5	12,7	12,3	11,5	10,7	9,5	14,0	
16,0							10,4	10,0	9,6	8,8	8,0	6,8	16,0	
18,0													18,0	
20,0													20,0	
22,0													22,0	
24,0													24,0	
26,0													26,0	
28,0													28,0	
30,0													30,0	
32,0													32,0	
34,0													34,0	
36,0													36,0	
Passagem	12	12					12					Passagem		
Gancho	60t												Gancho	
Modo telescópico	I	1	1	1	1	1	1	1	1	1	1	1	2	I
	II	1	1	1	1	1	2	1	1	1	1	2	2	II
	III	1	1	1	1	2	1	1	1	1	2	2	1	III
	IV	1	1	1	2	1	1	1	1	2	2	1	1	IV
	V	1	1	2	1	1	1	1	2	2	1	1	1	V
	VI	1	2	1	1	1	1	3	2	1	1	1	1	VI

Tabela 1-76 Tabela de capacidade de elevação (apenas com lança principal)

Unidade: tonelada

Estabilizadores totalmente estendidos para 5,3m, contrapeso de 19t, sobre a área de trabalho lateral ou traseira															
RAIO DE TRABALHO (m)	Comprimento de lança (m)												RAIO DE TRABALHO (m)		
	25,8	25,8	25,8	25,8	25,8	25,8 ★	30,0	30,0	30,0	30,0	30,0	30,0 ★			
3,0														3,0	
3,5														3,5	
4,0	25,0	25,0	43,0	55,0	55,0	55,0								4,0	
4,5	23,5	23,5	41,0	53,0	55,0	55,0								4,5	
5,0	22,0	22,0	39,5	51,0	53,0	53,0	19,0	24,0	26,0	42,0	50,0	50,0		5,0	
5,5	21,0	21,0	38,0	49,0	51,0	50,0	18,0	23,0	24,5	40,5	48,0	48,0		5,5	
6,0	20,0	20,0	36,0	47,0	46,0	45,0	17,5	22,0	23,0	39,5	44,0	43,0		6,0	
7,0	18,0	18,0	33,0	40,0	39,0	37,0	15,8	20,0	21,0	36,0	39,0	37,0		7,0	
8,0	16,5	16,5	30,0	31,0	30,0	28,0	14,3	18,5	19,0	33,0	31,5	30,0		8,0	
9,0	15,0	15,0	27,0	26,0	25,0	23,0	13,0	17,0	17,5	27,0	25,5	24,0		9,0	
10,0	14,0	14,0	23,0	22,0	21,0	19,0	12,0	15,5	16,0	23,0	21,5	20,0		10,0	
11,0	13,0	13,0	19,5	18,5	17,6	16,3	11,0	14,5	15,0	19,5	18,5	17,0		11,0	
12,0	12,1	12,1	17,0	16,0	15,1	13,8	10,3	13,5	14,0	17,0	16,0	14,5		12,0	
14,0	10,5	10,5	13,0	12,2	11,3	10,0	9,0	11,9	12,0	13,0	12,0	10,7		14,0	
16,0	9,4	9,3	10,5	9,7	8,8	7,5	8,0	10,7	10,6	10,4	9,4	8,1		16,0	
18,0	8,5	8,4	8,4	7,6	6,7	5,5	7,0	8,9	8,6	8,4	7,5	6,2		18,0	
20,0	7,3	7,1	6,9	6,1	5,2	3,9	6,3	7,3	7,0	6,8	5,9	4,6		20,0	
22,0							5,8	6,1	5,8	5,6	4,7	3,4		22,0	
24,0							5,3	5,0	4,8	4,6	3,7	2,4		24,0	
26,0														26,0	
28,0														28,0	
30,0														30,0	
32,0														32,0	
34,0														34,0	
36,0														36,0	
Passagem	11						9						Passagem		
Gancho	60t												Gancho		
Modo telescópico	I	1	1	1	1	1	2	1	1	1	1	1	2	I	Modo telescópico
	II	1	1	1	1	2	2	1	1	1	1	2	2	II	
	III	1	1	1	2	2	2	1	1	1	2	2	2	III	
	IV	1	1	2	2	2	1	1	2	3	2	2	2	IV	
	V	2	3	2	2	1	1	3	3	2	2	2	1	V	
	VI	3	2	2	1	1	1	3	2	2	2	1	1	VI	

Descrição do Guindaste

Tabela 1-77 Tabela de capacidade de elevação (apenas com lança principal)

Unidade: tonelada

Estabilizadores totalmente estendidos para 5,3m, contrapeso de 19t, sobre a área de trabalho lateral ou traseira														
RAIO DE TRABALHO (m)	Comprimento de lança (m)												RAIO DE TRABALHO (m)	
	34,2	34,2	34,2	34,2	34,2	34,2★	38,4	38,4	38,4	38,4	38,4	38,4★		
3,0														3,0
3,5														3,5
4,0														4,0
4,5														4,5
5,0														5,0
5,5														5,5
6,0	19,0	21,5	25,5	26,0	43,0	43,0								6,0
7,0	17,0	19,0	23,0	23,5	40,5	37,5	17,0	20,0	21,5	26,0	30,5	36,5		7,0
8,0	15,5	17,5	21,0	21,5	32,5	30,5	15,5	18,5	19,5	24,0	28,0	31,0		8,0
9,0	14,5	16,0	19,5	19,5	27,0	25,0	14,0	17,0	18,0	22,0	25,5	26,0		9,0
10,0	13,3	14,5	18,0	18,0	22,5	21,0	13,0	15,7	16,5	20,3	22,5	22,0		10,0
11,0	12,3	13,5	16,5	16,5	19,5	18,0	12,0	14,5	15,2	18,8	19,0	18,5		11,0
12,0	11,5	12,5	15,5	15,5	17,0	15,5	11,0	13,5	14,0	17,0	16,7	16,2		12,0
14,0	10,1	10,8	13,5	13,5	13,0	11,5	9,5	11,7	12,2	13,0	12,8	12,3		14,0
16,0	8,9	9,6	10,8	10,5	10,2	8,8	8,5	10,4	10,8	10,2	10,0	9,5		16,0
18,0	8,0	8,5	8,7	8,5	8,2	6,8	7,5	9,1	8,7	8,3	8,1	7,6		18,0
20,0	7,2	7,5	7,1	6,9	6,6	5,3	6,7	7,5	7,1	6,7	6,5	6,0		20,0
22,0	6,5	6,2	5,8	5,6	5,4	4,1	6,0	6,2	5,8	5,4	5,2	4,7		22,0
24,0	5,5	5,2	4,8	4,6	4,4	3,1	5,5	5,2	4,8	4,4	4,2	3,7		24,0
26,0	4,7	4,3	3,9	3,7	3,5	2,2	4,8	4,3	4,0	3,6	3,4	2,9		26,0
28,0	4,0	3,6	3,2	3,0	2,8	1,5	4,1	3,6	3,3	2,9	2,7	2,2		28,0
30,0							3,5	3,0	2,7	2,3	2,1	1,7		30,0
32,0							3,0	2,5	2,2	1,8	1,6	1,2		32,0
34,0														34,0
36,0														36,0
Passagem	8						7						Passagem	
Gancho	60t												Gancho	
Modo telescópico	I	1	1	1	1	1	2	1	1	1	1	1	2	I
	II	1	1	1	1	2	2	1	1	1	2	3	2	II
	III	1	1	2	3	2	2	1	2	3	3	2	2	III
	IV	2	3	3	2	2	2	3	3	3	2	2	2	IV
	V	3	3	2	2	2	2	3	3	2	2	2	2	V
	VI	3	2	2	2	2	1	3	2	2	2	2	2	VI

Tabela 1-78 Tabela de capacidade de elevação (apenas com lança principal)

Unidade: tonelada

Estabilizadores totalmente estendidos para 5,3m, contrapeso de 19t, sobre a área de trabalho lateral ou traseira															
RAIO DE TRABALHO (m)	Comprimento de lança (m)												RAIO DE TRABALHO (m)		
	42,6	42,6	42,6	42,6	42,6	42,6 ★		46,8	46,8	46,8	46,8	46,8 ★			
3,0														3,0	
3,5														3,5	
4,0														4,0	
4,5														4,5	
5,0														5,0	
5,5														5,5	
6,0														6,0	
7,0														7,0	
8,0	16,5	18,0	21,5	26,0	30,0	29,0								8,0	
9,0	15,0	16,5	20,0	24,0	25,5	25,0								9,0	
10,0	14,0	15,0	18,5	22,0	22,0	21,0		14,0	16,5	19,5	21,5	21,0		10,0	
11,0	12,9	14,0	17,0	19,0	18,5	18,0		12,8	15,3	18,0	18,5	18,0		11,0	
12,0	12,0	12,9	15,8	16,5	16,0	15,5		11,9	14,2	16,8	16,0	15,5		12,0	
14,0	10,4	11,0	13,2	12,8	12,2	11,7		10,3	12,3	13,0	12,3	11,8		14,0	
16,0	9,2	9,8	10,5	10,1	9,5	9,0		9,0	10,9	10,2	9,5	9,0		16,0	
18,0	8,2	8,6	8,5	8,1	7,5	7,0		8,0	8,8	8,3	7,6	7,1		18,0	
20,0	7,3	7,4	6,9	6,5	5,9	5,4		7,1	7,2	6,7	6,0	5,5		20,0	
22,0	6,5	6,1	5,6	5,2	4,6	4,3		6,4	6,0	5,5	4,8	4,3		22,0	
24,0	5,5	5,1	4,6	4,2	3,6	3,3		5,5	5,0	4,5	3,8	3,3		24,0	
26,0	4,7	4,3	3,8	3,4	2,8	2,5		4,7	4,2	3,7	3,0	2,5		26,0	
28,0	4,0	3,6	3,1	2,7	2,1	1,8		3,9	3,4	2,9	2,3	1,8		28,0	
30,0	3,4	3,0	2,5	2,1	1,5	1,2		3,3	2,8	2,3	1,7	1,2		30,0	
32,0														32,0	
34,0														34,0	
36,0														36,0	
Passagem	6							5						Passagem	
Gancho	60t												Gancho		
Modo telescópico	I	1	1	1	1	2	3		1	1	1	2	3	I	Modo telescópico
	II	1	1	2	3	3	2		1	2	3	3	3	II	
	III	2	3	3	3	2	2		3	3	3	3	2	III	
	IV	3	3	3	2	2	2		3	3	3	2	2	IV	
	V	3	3	2	2	2	2		3	3	2	2	2	V	
	VI	3	2	2	2	2	2		3	2	2	2	2	VI	

Descrição do Guindaste

Tabela 1-79 Tabela de capacidade de elevação (apenas com lança principal)

Unidade: tonelada

Estabilizadores totalmente estendidos para 5,3m, contrapeso de 19t, sobre a área de trabalho lateral ou traseira														
RAIO DE TRABALHO (m)	Comprimento de lança (m)												RAIO DE TRABALHO (m)	
	51,0	51,0	51,0	51,0 ★	55,2	55,2	55,2 ★		59,4	59,4 ★	63,6 ★	70,0 ★		
3,0														3,0
3,5														3,5
4,0														4,0
4,5														4,5
5,0														5,0
5,5														5,5
6,0														6,0
7,0														7,0
8,0														8,0
9,0														9,0
10,0														10,0
11,0	13,5	15,5	18,0	18,0										11,0
12,0	13,0	14,5	16,0	15,5	13,0	14,0	14,5							12,0
14,0	11,3	13,0	12,5	12,0	11,5	12,5	12,0		11,0	11,5				14,0
16,0	10,0	10,5	10,0	9,3	10,5	10,0	9,5		10,0	9,5	9,5			16,0
18,0	9,0	8,6	7,9	7,2	9,0	8,2	7,5		8,5	7,8	8,0	7,0		18,0
20,0	7,7	7,0	6,3	5,6	7,4	6,6	5,9		7,0	6,3	6,6	6,7		20,0
22,0	6,4	5,8	5,0	4,4	6,2	5,4	4,7		5,7	5,0	5,4	5,5		22,0
24,0	5,4	4,8	4,0	3,4	5,2	4,4	3,7		4,7	4,0	4,4	4,5		24,0
26,0	4,5	4,0	3,2	2,6	4,3	3,5	2,8		3,8	3,1	3,5	3,6		26,0
28,0	3,8	3,3	2,5	1,9	3,6	2,8	2,1		3,2	2,5	2,9	3,0		28,0
30,0	3,2	2,7	1,9	1,3	3,0	2,2	1,5		2,6	1,9	2,3	2,4		30,0
32,0					2,5	1,7	1,0		2,0	1,3	1,7	1,8		32,0
34,0									1,6	0,9	1,2	1,3		34,0
36,0											0,9	1,0		36,0
Passagem	4			3			3			3			Passagem	
Gancho	60t												Gancho	
Modo telescópico	I	1	1	2	3	1	2	3		2	3	3	4	I
	II	2	3	3	3	3	3	3		3	3	3	4	II
	III	3	3	3	3	3	3	3		3	3	3	4	III
	IV	3	3	3	2	3	3	3		3	3	3	4	IV
	V	3	3	2	2	3	3	2		3	3	3	4	V
	VI	3	2	2	2	3	2	2		3	2	3	4	VI

Tabela 1-80 Tabela de capacidade de elevação (apenas com lança principal)

Unidade: tonelada

Estabilizadores totalmente estendidos para 5,3m, contrapeso de 15t, sobre a área de trabalho lateral ou traseira														
RAIO DE TRABALHO (m)	Comprimento de lança (m)												RAIO DE TRABALHO (m)	
	13,2 ★	17,4	17,4	17,4	17,4	17,4 ★	21,6	21,6	21,6	21,6	21,6	21,6 ★		
3,0	70,0	40,0	65,0	65,0	65,0	65,0	29,5	40,0	60,0	60,0	60,0	60,0	3,0	
3,5	67,0	37,0	60,0	60,0	60,0	60,0	27,5	38,0	56,0	60,0	60,0	60,0	3,5	
4,0	64,0	35,0	56,5	57,0	57,0	57,0	26,0	36,0	53,0	60,0	60,0	60,0	4,0	
4,5	60,0	33,0	52,5	54,0	54,0	53,0	24,0	34,0	50,0	55,0	55,0	55,0	4,5	
5,0	56,0	31,5	49,0	52,0	50,0	49,0	23,0	33,0	48,0	52,0	52,0	52,0	5,0	
5,5	49,0	30,0	46,0	47,0	46,0	45,0	22,0	31,5	44,0	46,0	45,0	45,0	5,5	
6,0	43,0	28,5	43,0	42,0	39,0	38,0	21,0	30,0	41,0	40,0	39,0	38,0	6,0	
7,0	31,5	27,0	34,5	33,5	33,0	32,0	19,0	28,0	35,0	34,0	33,0	32,0	7,0	
8,0	25,0	25,5	27,5	26,5	26,0	25,0	17,0	26,0	28,0	27,5	26,5	25,0	8,0	
9,0	20,0	22,5	22,0	21,5	21,0	20,5	16,0	23,5	23,0	22,5	21,5	20,0	9,0	
10,0		19,0	18,5	18,0	17,5	17,0	15,0	19,5	19,0	18,5	17,5	16,2	10,0	
11,0		16,0	15,5	15,0	14,5	14,0	13,9	17,0	16,5	15,8	14,8	13,5	11,0	
12,0		13,5	13,2	12,8	12,3	11,8	13,0	14,6	14,1	13,4	12,4	11,2	12,0	
14,0							11,3	11,0	10,5	9,8	9,0	7,8	14,0	
16,0							8,8	8,6	8,1	7,4	6,6	5,4	16,0	
18,0													18,0	
20,0													20,0	
22,0													22,0	
24,0													24,0	
26,0													26,0	
28,0													28,0	
30,0													30,0	
32,0													32,0	
Passagem	12	12					12					Passagem		
Gancho	60t													Gancho
Modo telescópico	I	1	1	1	1	1	1	1	1	1	1	1	2	Modo telescópico
	II	1	1	1	1	1	2	1	1	1	1	2	2	
	III	1	1	1	1	2	1	1	1	1	2	2	1	
	IV	1	1	1	2	1	1	1	1	2	2	1	1	
	V	1	1	2	1	1	1	1	2	2	1	1	1	
	VI	1	2	1	1	1	1	3	2	1	1	1	1	

Descrição do Guindaste

Tabela 1-81 Tabela de capacidade de elevação (apenas com lança principal)

Unidade: tonelada

Estabilizadores totalmente estendidos para 5,3m, contrapeso de 15t, sobre a área de trabalho lateral ou traseira														
RAIO DE TRABALHO (m)	Comprimento de lança (m)												RAIO DE TRABALHO (m)	
	25,8	25,8	25,8	25,8	25,8	25,8 ★	30,0	30,0	30,0	30,0	30,0	30,0		30,0 ★
3,0														3,0
3,5														3,5
4,0	25,0	25,0	43,0	55,0	55,0	55,0								4,0
4,5	23,5	23,5	41,0	53,0	55,0	55,0								4,5
5,0	22,0	22,0	39,5	51,0	52,0	52,0	19,0	24,0	26,0	42,0	50,0	50,0		5,0
5,5	21,0	21,0	38,0	49,0	47,0	46,0	18,0	23,0	24,5	40,5	48,0	48,0		5,5
6,0	20,0	20,0	36,0	44,0	43,0	42,0	17,5	22,0	23,0	39,5	42,0	41,0		6,0
7,0	18,0	18,0	33,0	33,0	33,0	32,0	15,8	20,0	21,0	35,0	33,5	32,0		7,0
8,0	16,5	16,5	29,5	28,0	27,0	25,5	14,3	18,5	19,0	29,0	27,5	26,0		8,0
9,0	15,0	15,0	24,0	23,0	22,0	20,5	13,0	17,0	17,5	24,5	23,0	21,5		9,0
10,0	14,0	14,0	20,0	19,0	18,0	17,0	12,0	15,5	16,0	20,0	19,0	17,5		10,0
11,0	13,0	13,0	17,0	16,0	15,0	14,0	11,0	14,5	15,0	17,0	16,0	14,5		11,0
12,0	12,1	12,1	15,0	14,0	13,0	11,7	10,3	13,5	14,0	15,0	14,0	12,5		12,0
14,0	10,5	10,5	11,5	10,5	9,5	8,2	9,0	11,9	11,8	11,5	10,5	9,0		14,0
16,0	9,4	9,3	9,0	8,2	7,2	5,9	8,0	9,5	9,3	9,0	8,1	6,6		16,0
18,0	7,6	7,4	7,1	6,3	5,5	4,2	7,0	7,6	7,4	7,1	6,2	4,9		18,0
20,0	6,2	6,0	5,8	5,0	4,2	2,9	6,3	6,2	6,0	5,7	4,8	3,5		20,0
22,0							5,5	5,2	5,0	4,7	3,8	2,5		22,0
24,0							4,5	4,2	4,0	3,7	2,8	1,5		24,0
26,0														26,0
28,0														28,0
30,0														30,0
32,0														32,0
Passagem	11						9						Passagem	
Gancho	60t												Gancho	
Modo telescópico	I	1	1	1	1	1	2	1	1	1	1	1	2	I
	II	1	1	1	1	2	2	1	1	1	1	2	2	II
	III	1	1	1	2	2	2	1	1	1	2	2	2	III
	IV	1	1	2	2	2	1	1	2	3	2	2	2	IV
	V	2	3	2	2	1	1	3	3	2	2	2	1	V
	VI	3	2	2	1	1	1	3	2	2	2	1	1	VI
														Modo telescópico

Tabela 1-82 Tabela de capacidade de elevação (apenas com lança principal)

Unidade: tonelada

Estabilizadores totalmente estendidos para 5,3m, contrapeso de 15t, sobre a área de trabalho lateral ou traseira														
RAIO DE TRABALHO (m)	Comprimento de lança (m)												RAIO DE TRABALHO (m)	
	34,2	34,2	34,2	34,2	34,2	34,2 ★	38,4	38,4	38,4	38,4	38,4	38,4		38,4 4★
3,0														3,0
3,5														3,5
4,0														4,0
4,5														4,5
5,0														5,0
5,5														5,5
6,0	19,0	21,5	25,5	26,0	43,0	42,0								6,0
7,0	17,0	19,0	23,0	23,5	35,5	33,0	17,0	20,0	21,5	26,0	30,5	33,0		7,0
8,0	15,5	17,5	21,0	21,5	29,0	27,0	15,5	18,5	19,5	24,0	28,0	27,5		8,0
9,0	14,5	16,0	19,5	19,5	24,0	22,0	14,0	17,0	18,0	22,0	23,5	23,0		9,0
10,0	13,3	14,5	18,0	18,0	20,0	18,5	13,0	15,7	16,5	20,3	20,0	19,5		10,0
11,0	12,3	13,5	16,5	16,5	17,0	15,5	12,0	14,5	15,2	17,4	17,0	16,5		11,0
12,0	11,5	12,5	15,5	15,2	14,8	13,3	11,0	13,5	14,0	15,0	14,6	14,1		12,0
14,0	10,1	10,8	11,8	11,6	11,2	9,8	9,5	11,7	11,8	11,3	11,0	10,5		14,0
16,0	8,9	9,6	9,3	9,1	8,7	7,5	8,5	9,6	9,3	8,8	8,6	8,1		16,0
18,0	8,0	7,9	7,4	7,2	6,9	5,7	7,5	7,8	7,5	7,0	6,8	6,3		18,0
20,0	6,8	6,5	6,0	5,8	5,5	4,3	6,7	6,3	6,0	5,5	5,3	4,8		20,0
22,0	5,6	5,3	4,9	4,7	4,4	3,2	5,7	5,2	4,9	4,4	4,2	3,7		22,0
24,0	4,7	4,4	4,0	3,8	3,5	2,3	4,8	4,3	4,0	3,6	3,4	2,9		24,0
26,0	3,9	3,6	3,2	3,0	2,7	1,5	4,0	3,5	3,2	2,8	2,6	2,1		26,0
28,0	3,3	3,0	2,6	2,4	2,1	0,9	3,4	2,9	2,6	2,2	2,0	1,5		28,0
30,0							2,8	2,3	2,0	1,6	1,4	1,0		30,0
32,0														32,0
Passagem	8						7						Passagem	
Gancho	60t												Gancho	
Modo telescópico	I	1	1	1	1	1	2	1	1	1	1	1	2	Modo telescópico
	II	1	1	1	1	2	2	1	1	1	2	3	2	
	III	1	1	2	3	2	2	1	2	3	3	2	2	
	IV	2	3	3	2	2	2	3	3	3	2	2	2	
	V	3	3	2	2	2	2	3	3	2	2	2	2	
	VI	3	2	2	2	2	1	3	2	2	2	2	2	

Descrição do Guindaste

Tabela 1-83 Tabela de capacidade de elevação (apenas com lança principal)

Unidade: tonelada

Estabilizadores totalmente estendidos para 5,3m, contrapeso de 15t, sobre a área de trabalho lateral ou traseira														
RAIO DE TRABALHO (m)	Comprimento de lança (m)												RAIO DE TRABALHO (m)	
	42,6	42,6	42,6	42,6	42,6	42,6★		46,8	46,8	46,8	46,8	46,8★		
3,0														3,0
3,5														3,5
4,0														4,0
4,5														4,5
5,0														5,0
5,5														5,5
6,0														6,0
7,0														7,0
8,0	16,5	18,0	21,5	26,0	27,0	26,5								8,0
9,0	15,0	16,5	20,0	24,0	23,0	22,5								9,0
10,0	14,0	15,0	18,5	20,0	19,3	18,8		14,0	16,5	19,5	19,0	18,5		10,0
11,0	12,9	14,0	17,0	17,2	16,5	16,0		12,8	15,3	17,5	16,5	16,0		11,0
12,0	12,0	12,9	15,2	14,8	14,2	13,7		11,9	14,2	15,0	14,3	13,5		12,0
14,0	10,4	11,0	11,6	11,2	10,6	10,1		10,3	12,0	11,5	10,7	10,0		14,0
16,0	9,2	9,6	9,1	8,7	8,1	7,7		9,0	9,5	9,0	8,3	7,6		16,0
18,0	8,2	7,7	7,2	6,8	6,2	5,9		8,0	7,6	7,1	6,4	5,8		18,0
20,0	6,8	6,3	5,8	5,4	4,8	4,5		6,8	6,2	5,7	5,0	4,4		20,0
22,0	5,7	5,2	4,7	4,3	3,7	3,4		5,6	5,0	4,5	3,9	3,3		22,0
24,0	4,8	4,3	3,8	3,4	2,8	2,5		4,7	4,1	3,6	3,0	2,4		24,0
26,0	4,0	3,5	3,0	2,6	2,0	1,7		3,9	3,3	2,8	2,2	1,6		26,0
28,0	3,3	2,8	2,3	2,0	1,4	1,1		3,3	2,7	2,2	1,6	1,0		28,0
30,0														30,0
32,0														32,0
Passagem	6						5						Passagem	
Gancho	60t												Gancho	
Modo telescópico	I	1	1	1	1	2	3		1	1	1	2	3	I
	II	1	1	2	3	3	2		1	2	3	3	3	II
	III	2	3	3	3	2	2		3	3	3	3	2	III
	IV	3	3	3	2	2	2		3	3	3	2	2	IV
	V	3	3	2	2	2	2		3	3	2	2	2	V
	VI	3	2	2	2	2	2		3	2	2	2	2	VI

Tabela 1-84 Tabela de capacidade de elevação (apenas com lança principal)

Unidade: tonelada

Estabilizadores totalmente estendidos para 5,3m, contrapeso de 15t, sobre a área de trabalho lateral ou traseira														
RAIO DE TRABALHO (m)	Comprimento de lança (m)												RAIO DE TRABALHO (m)	
	51,0	51,0	51,0	51,0 ★	55,2	55,2	55,2 ★		59,4	59,4 ★	63,6 ★	70,0 ★		
3,0														3,0
3,5														3,5
4,0														4,0
4,5														4,5
5,0														5,0
5,5														5,5
6,0														6,0
7,0														7,0
8,0														8,0
9,0														9,0
10,0														10,0
11,0	13,5	15,5	16,0	15,5										11,0
12,0	13,0	14,5	14,0	13,3	13,0	14,0	13,5							12,0
14,0	11,3	11,8	11,0	10,3	11,5	11,2	10,5		11,0	10,5				14,0
16,0	9,8	9,2	8,4	7,8	9,6	8,8	8,1		9,2	8,5	8,5			16,0
18,0	8,0	7,4	6,6	6,0	7,8	7,0	6,3		7,3	6,5	7,0	7,0		18,0
20,0	6,6	6,0	5,2	4,6	6,3	5,5	4,8		5,9	5,2	5,5	5,6		20,0
22,0	5,5	4,9	4,1	3,5	5,3	4,5	3,8		4,7	4,1	4,5	4,6		22,0
24,0	4,5	4,0	3,2	2,6	4,3	3,5	2,8		3,8	3,2	3,6	3,7		24,0
26,0	3,7	3,2	2,4	1,8	3,5	2,7	2,0		3,0	2,4	2,8	2,9		26,0
28,0	3,0	2,5	1,8	1,2	2,9	2,1	1,4		2,4	1,7	2,1	2,2		28,0
30,0					2,3	1,5	0,9		1,9	1,2	1,5	1,6		30,0
32,0											1,1	1,2		32,0
Passagem	4				3					3		3	3	Passagem
Gancho	60t												Gancho	
Modo telescópico	I	1	1	2	3	1	2	3		2	3	3	4	I
	II	2	3	3	3	3	3	3		3	3	3	4	II
	III	3	3	3	3	3	3	3		3	3	3	4	III
	IV	3	3	3	2	3	3	3		3	3	3	4	IV
	V	3	3	2	2	3	3	2		3	3	3	4	V
	VI	3	2	2	2	3	2	2		3	2	3	4	VI
														Modo telescópico

Descrição do Guindaste

Tabela 1-85 Tabela de capacidade de elevação (apenas com lança principal)

Unidade: tonelada

Estabilizadores totalmente estendidos para 5,3m, contrapeso de 11t, sobre a área de trabalho lateral ou traseira														
RAIO DE TRABALHO (m)	Comprimento de lança (m)												RAIO DE TRABALHO (m)	
	13,2 ★	17,4	17,4	17,4	17,4	17,4 ★	21,6	21,6	21,6	21,6	21,6	21,6 ★		
3,0	70,0	40,0	65,0	65,0	65,0	65,0	29,5	40,0	60,0	60,0	60,0	60,0	3,0	
3,5	67,0	37,0	60,0	60,0	60,0	60,0	27,5	38,0	56,0	60,0	60,0	60,0	3,5	
4,0	64,0	35,0	56,5	57,0	57,0	57,0	26,0	36,0	53,0	60,0	60,0	60,0	4,0	
4,5	60,0	33,0	52,5	54,0	54,0	53,0	24,0	34,0	50,0	55,0	55,0	55,0	4,5	
5,0	52,0	31,5	49,0	52,0	50,0	49,0	23,0	33,0	48,0	52,0	52,0	52,0	5,0	
5,5	45,0	30,0	46,0	47,0	46,0	45,0	22,0	31,5	44,0	46,0	45,0	43,0	5,5	
6,0	38,0	28,5	41,5	41,0	39,0	38,0	21,0	30,0	41,0	40,0	39,0	36,0	6,0	
7,0	28,0	27,0	31,0	30,5	29,0	28,5	19,0	28,0	31,5	31,0	30,0	28,0	7,0	
8,0	21,5	24,5	24,0	23,5	23,0	22,5	17,0	26,0	25,0	24,5	23,5	21,5	8,0	
9,0	17,0	20,0	19,5	19,0	18,5	18,0	16,0	21,0	20,0	19,5	18,5	17,0	9,0	
10,0		16,5	16,0	15,5	15,0	14,5	15,0	17,5	16,5	16,0	15,0	13,5	10,0	
11,0		13,8	13,3	12,8	12,3	11,8	13,9	14,8	14,2	13,5	12,5	11,0	11,0	
12,0		11,7	11,2	10,7	10,2	9,7	12,5	12,6	12,0	11,3	10,5	9,0	12,0	
14,0							9,6	9,5	8,9	8,2	7,4	6,1	14,0	
16,0							7,4	7,3	6,7	6,0	5,2	3,9	16,0	
18,0													18,0	
20,0													20,0	
22,0													22,0	
24,0													24,0	
26,0													26,0	
28,0													28,0	
30,0													30,0	
Passagem	12	12					12					Passagem		
Gancho	60t												Gancho	
Modo telescópico	I	1	1	1	1	1	1	1	1	1	1	1	2	Modo telescópico
	II	1	1	1	1	1	2	1	1	1	1	2	2	
	III	1	1	1	1	2	1	1	1	1	2	2	1	
	IV	1	1	1	2	1	1	1	1	2	2	1	1	
	V	1	1	2	1	1	1	1	2	2	1	1	1	
	VI	1	2	1	1	1	1	3	2	1	1	1	1	

Tabela 1-86 Tabela de capacidade de elevação (apenas com lança principal)

Unidade: tonelada

Estabilizadores totalmente estendidos para 5,3m, contrapeso de 11t, sobre a área de trabalho lateral ou traseira														
RAIO DE TRABALHO (m)	Comprimento de lança (m)												RAIO DE TRABALHO (m)	
	25,8	25,8	25,8	25,8	25,8	25,8 ★	30,0	30,0	30,0	30,0	30,0	30,0		30,0 ★
3,0														3,0
3,5														3,5
4,0	25,0	25,0	43,0	55,0	55,0	55,0								4,0
4,5	23,5	23,5	41,0	53,0	53,0	53,0								4,5
5,0	22,0	22,0	39,5	51,0	51,0	51,0	19,0	24,0	26,0	42,0	50,0	50,0		5,0
5,5	21,0	21,0	38,0	45,0	44,0	43,0	18,0	23,0	24,5	40,5	42,5	41,0		5,5
6,0	20,0	20,0	36,0	39,0	38,0	37,0	17,5	22,0	23,0	39,0	38,5	37,0		6,0
7,0	18,0	18,0	33,0	30,0	29,0	28,0	15,8	20,0	21,0	31,5	30,5	29,0		7,0
8,0	16,5	16,5	26,5	23,0	22,0	21,0	14,3	18,5	19,0	25,5	24,5	23,0		8,0
9,0	15,0	15,0	21,7	19,5	18,5	17,5	13,0	17,0	17,5	21,0	20,0	18,5		9,0
10,0	14,0	14,0	18,0	16,5	15,5	14,5	12,0	15,5	16,0	17,5	16,5	15,0		10,0
11,0	13,0	13,0	15,2	14,3	13,3	11,8	11,0	14,5	15,0	15,2	14,2	12,7		11,0
12,0	12,1	12,0	13,0	12,2	11,2	9,7	10,3	13,5	13,4	13,0	12,0	10,5		12,0
14,0	10,4	10,2	9,8	9,0	8,1	6,7	9,0	10,4	10,1	9,8	8,8	7,5		14,0
16,0	8,1	7,9	7,5	6,7	5,8	4,4	8,0	8,1	7,8	7,6	6,6	5,3		16,0
18,0	6,4	6,2	6,0	5,2	4,3	2,9	6,9	6,5	6,2	6,0	5,0	3,7		18,0
20,0	5,1	4,9	4,7	4,0	3,1	1,7	5,6	5,2	4,9	4,7	3,7	2,4		20,0
22,0							4,5	4,1	3,9	3,7	2,7	1,4		22,0
24,0														24,0
26,0														26,0
28,0														28,0
30,0														30,0
Passagem	11						9						Passagem	
Gancho	60t												Gancho	
Modo telescópico	I	1	1	1	1	1	2	1	1	1	1	1	2	Modo telescópico
	II	1	1	1	1	2	2	1	1	1	1	2	2	
	III	1	1	1	2	2	2	1	1	1	2	2	2	
	IV	1	1	2	2	2	1	1	2	3	2	2	2	
	V	2	3	2	2	1	1	3	3	2	2	2	1	
	VI	3	2	2	1	1	1	3	2	2	2	1	1	

Descrição do Guindaste

Tabela 1-87 Tabela de capacidade de elevação (apenas com lança principal)

Unidade: tonelada

Estabilizadores totalmente estendidos para 5,3m, contrapeso de 11t, sobre a área de trabalho lateral ou traseira															
RAIO DE TRABALHO (m)	Comprimento de lança (m)												RAIO DE TRABALHO (m)		
	34,2	34,2	34,2	34,2	34,2	34,2★	38,4	38,4	38,4	38,4	38,4	38,4★			
3,0														3,0	
3,5														3,5	
4,0														4,0	
4,5														4,5	
5,0														5,0	
5,5														5,5	
6,0	19,0	21,5	25,5	26,0	40,0	38,0								6,0	
7,0	17,0	19,0	23,0	23,5	31,0	29,0	17,0	20,0	21,5	26,0	29,5	29,0		7,0	
8,0	15,5	17,5	21,0	21,5	25,0	23,5	15,5	18,5	19,5	24,0	24,5	24,0		8,0	
9,0	14,5	16,0	19,5	19,5	21,0	19,5	14,0	17,0	18,0	21,5	20,5	20,0		9,0	
10,0	13,3	14,5	18,0	18,0	17,7	16,2	13,0	15,7	16,5	18,0	17,5	17,0		10,0	
11,0	12,3	13,5	15,6	15,3	15,0	13,5	12,0	14,5	15,2	15,0	14,7	14,2		11,0	
12,0	11,5	12,5	13,4	13,2	12,9	11,4	11,0	13,5	13,0	12,9	12,6	12,1		12,0	
14,0	10,1	10,6	10,2	10,0	9,7	8,2	9,5	10,6	10,2	9,7	9,4	8,9		14,0	
16,0	8,6	8,2	7,8	7,6	7,3	6,0	8,5	8,3	7,9	7,5	7,2	6,7		16,0	
18,0	7,0	6,6	6,2	6,0	5,7	4,4	7,1	6,6	6,2	5,8	5,6	5,1		18,0	
20,0	5,6	5,3	4,9	4,7	4,4	3,1	5,8	5,3	4,9	4,5	4,3	3,8		20,0	
22,0	4,6	4,3	3,9	3,7	3,4	2,2	4,7	4,2	3,9	3,5	3,3	2,8		22,0	
24,0	3,8	3,5	3,1	2,9	2,6	1,4	3,9	3,4	3,1	2,7	2,5	2,1		24,0	
26,0							3,2	2,7	2,4	2,0	1,8	1,4		26,0	
28,0							2,6	2,1	1,8	1,4	1,2	0,8		28,0	
30,0														30,0	
Passagem	8						7						Passagem		
Gancho	60t												Gancho		
Modo telescópico	I	1	1	1	1	1	2	1	1	1	1	2	I	Modo telescópico	
	II	1	1	1	1	2	2	1	1	1	2	3	2		II
	III	1	1	2	3	2	2	1	2	3	3	2	2		III
	IV	2	3	3	2	2	2	3	3	3	2	2	2		IV
	V	3	3	2	2	2	2	3	3	2	2	2	2		V
	VI	3	2	2	2	2	1	3	2	2	2	2	2		VI

Tabela 1-88 Tabela de capacidade de elevação (apenas com lança principal)

Unidade: tonelada

Estabilizadores totalmente estendidos para 5,3m, contrapeso de 11t, sobre a área de trabalho lateral ou traseira														
RAIO DE TRABALHO (m)	Comprimento de lança (m)												RAIO DE TRABALHO (m)	
	42,6	42,6	42,6	42,6	42,6	42,6 ★		46,8	46,8	46,8	46,8	46,8 ★		
3,0														3,0
3,5														3,5
4,0														4,0
4,5														4,5
5,0														5,0
5,5														5,5
6,0														6,0
7,0														7,0
8,0	16,5	18,0	21,5	24,5	23,5	23,0								8,0
9,0	15,0	16,5	20,0	20,5	19,5	19,0								9,0
10,0	14,0	15,0	18,3	17,8	17,0	16,5		14,0	16,5	17,5	16,5	16,0		10,0
11,0	12,9	14,0	15,5	15,0	14,2	13,7		12,8	15,3	15,3	14,5	13,7		11,0
12,0	12,0	12,9	13,3	12,8	12,0	11,5		11,9	13,6	13,0	12,3	11,7		12,0
14,0	10,4	10,6	10,0	9,5	8,9	8,5		10,3	10,4	9,8	9,1	8,5		14,0
16,0	8,7	8,2	7,7	7,2	6,6	6,2		8,7	8,1	7,5	6,8	6,2		16,0
18,0	7,0	6,5	6,0	5,6	5,0	4,6		7,0	6,4	5,9	5,2	4,6		18,0
20,0	5,7	5,2	4,7	4,3	3,8	3,4		5,6	5,0	4,5	3,8	3,2		20,0
22,0	4,8	4,3	3,8	3,4	2,8	2,4		4,6	4,0	3,6	2,9	2,3		22,0
24,0	3,9	3,4	2,9	2,5	1,9	1,5		3,8	3,2	2,8	2,1	1,5		24,0
26,0	3,2	2,7	2,2	1,9	1,3	0,9		3,1	2,5	2,1	1,4	0,8		26,0
28,0														28,0
30,0														30,0
Passagem	6						5						Passagem	
Gancho	60t												Gancho	
Modo telescópico	I	1	1	1	1	2	3		1	1	1	2	3	I
	II	1	1	2	3	3	2		1	2	3	3	3	II
	III	2	3	3	3	2	2		3	3	3	3	2	III
	IV	3	3	3	2	2	2		3	3	3	2	2	IV
	V	3	3	2	2	2	2		3	3	2	2	2	V
	VI	3	2	2	2	2	2		3	2	2	2	2	VI

Descrição do Guindaste

Tabela 1-89 Tabela de capacidade de elevação (apenas com lança principal)

Unidade: tonelada

Estabilizadores totalmente estendidos para 5,3m, contrapeso de 11t, sobre a área de trabalho lateral ou traseira														
RAIO DE TRABALHO (m)	Comprimento de lança (m)												RAIO DE TRABALHO (m)	
	51,0	51,0	51,0	51,0 ★	55,2	55,2	55,2 ★		59,4	59,4 ★	63,6 ★	70,0 ★		
3,0														3,0
3,5														3,5
4,0														4,0
4,5														4,5
5,0														5,0
5,5														5,5
6,0														6,0
7,0														7,0
8,0														8,0
9,0														9,0
10,0														10,0
11,0	13,5	15,5	14,5	13,5										11,0
12,0	13,0	13,5	12,5	11,6	13,0	12,5	12,0							12,0
14,0	10,7	10,2	9,4	8,5	10,5	9,7	9,0		10,0	9,0				14,0
16,0	8,5	8,0	7,2	6,5	8,2	7,4	6,7		7,8	7,1	7,0			16,0
18,0	6,8	6,3	5,5	4,8	6,6	5,8	5,1		6,1	5,4	5,8	5,5		18,0
20,0	5,5	5,0	4,2	3,5	5,3	4,5	3,8		4,8	4,1	4,5	4,6		20,0
22,0	4,4	3,9	3,1	2,5	4,3	3,5	2,8		3,8	3,1	3,5	3,6		22,0
24,0	3,6	3,1	2,3	1,7	3,4	2,6	1,9		3,0	2,3	2,6	2,7		24,0
26,0	2,9	2,4	1,6	1,0	2,7	1,9	1,2		2,3	1,6	1,9	2,0		26,0
28,0									1,7	1,0	1,3	1,4		28,0
30,0											0,8	0,9		30,0
Passagem	4				3					3		3	3	Passagem
Gancho	60t												Gancho	
Modo telescópico	I	1	1	2	3	1	2	3		2	3	3	4	I
	II	2	3	3	3	3	3	3		3	3	3	4	II
	III	3	3	3	3	3	3	3		3	3	3	4	III
	IV	3	3	3	2	3	3	3		3	3	3	4	IV
	V	3	3	2	2	3	3	2		3	3	3	4	V
	VI	3	2	2	2	3	2	2		3	2	3	4	VI

Tabela 1-90 Tabela de capacidade de elevação (apenas com lança principal)

Unidade: tonelada

Estabilizadores totalmente estendidos para 5,3m, contrapeso de 3t, sobre a área de trabalho lateral ou traseira														
RAIO DE TRABALHO (m)	Comprimento de lança (m)											RAIO DE TRABALHO (m)		
	13,2 ★	17,4	17,4	17,4	17,4	17,4	17,4 ★	21,6	21,6	21,6	21,6		21,6	21,6 ★
3,0	70,0	40,0	65,0	65,0	65,0	65,0	65,0	29,5	40,0	60,0	60,0	60,0	60,0	3,0
3,5	67,0	37,0	60,0	60,0	60,0	60,0	60,0	27,5	38,0	56,0	60,0	60,0	60,0	3,5
4,0	60,0	35,0	55,0	55,0	55,0	55,0	55,0	26,0	36,0	53,0	55,0	55,0	55,0	4,0
4,5	50,0	33,0	51,0	50,0	50,0	50,0	50,0	24,0	34,0	50,0	49,0	49,0	48,0	4,5
5,0	41,0	31,5	43,0	42,0	41,0	40,0	40,0	23,0	33,0	39,0	38,0	38,0	37,0	5,0
5,5	33,0	30,0	35,5	34,5	34,0	33,0	33,0	22,0	31,5	34,5	33,5	32,5	31,0	5,5
6,0	27,0	28,5	29,5	28,5	28,0	27,0	27,0	21,0	30,0	29,5	28,5	27,5	26,0	6,0
7,0	19,0	22,0	21,5	21,0	20,5	19,5	19,5	19,0	23,0	22,5	21,5	20,5	19,0	7,0
8,0	14,0	17,0	16,5	16,0	15,5	15,0	15,0	17,0	18,5	18,0	17,0	16,0	14,5	8,0
9,0	10,5	13,5	13,0	12,8	12,5	12,0	12,0	15,5	15,0	14,5	13,5	12,5	11,0	9,0
10,0		11,0	10,5	10,3	10,0	9,4	9,4	12,5	12,0	11,5	11,0	10,0	8,6	10,0
11,0		9,0	8,5	8,3	8,0	7,4	7,4	10,5	10,0	9,5	9,0	8,0	6,6	11,0
12,0		7,5	7,0	6,8	6,5	5,9	5,9	9,0	8,5	8,0	7,3	6,5	5,1	12,0
14,0								6,5	6,2	5,7	5,0	4,2	2,8	14,0
16,0								4,8	4,5	4,0	3,3	2,5	1,1	16,0
18,0														18,0
20,0														20,0
22,0														22,0
24,0														24,0
Passagem	12	12					12					Passagem		
Gancho	60t													Gancho
Modo telescópico	I	1	1	1	1	1	1	1	1	1	1	1	2	I
	II	1	1	1	1	1	2	1	1	1	1	2	2	II
	III	1	1	1	1	2	1	1	1	1	2	2	1	III
	IV	1	1	1	2	1	1	1	1	2	2	1	1	IV
	V	1	1	2	1	1	1	1	2	2	1	1	1	V
	VI	1	2	1	1	1	1	3	2	1	1	1	1	VI

Descrição do Guindaste

Tabela 1-91 Tabela de capacidade de elevação (apenas com lança principal)

Unidade: tonelada

Estabilizadores totalmente estendidos para 5,3m, contrapeso de 3t, sobre a área de trabalho lateral ou traseira															
RAIO DE TRABALHO (m)	Comprimento de lança (m)												RAIO DE TRABALHO (m)		
	25,8	25,8	25,8	25,8	25,8	25,8★	30,0	30,0	30,0	30,0	30,0	30,0★			
3,0														3,0	
3,5														3,5	
4,0	25,0	25,0	43,0	50,0	50,0	50,0								4,0	
4,5	23,5	23,5	41,0	46,0	46,0	46,0								4,5	
5,0	22,0	22,0	39,5	40,0	38,5	37,0	19,0	24,0	26,0	42,0	38,5	37,0		5,0	
5,5	21,0	21,0	36,0	35,0	33,5	32,0	18,0	23,0	24,5	34,0	32,5	31,0		5,5	
6,0	20,0	20,0	31,0	30,0	28,5	27,0	17,5	22,0	23,0	30,0	28,5	27,0		6,0	
7,0	18,0	18,0	24,0	23,0	21,5	20,0	15,8	20,0	21,0	23,0	21,5	20,0		7,0	
8,0	16,5	16,5	18,5	17,5	16,5	15,0	14,3	18,5	19,0	18,5	17,0	15,5		8,0	
9,0	15,0	15,0	15,0	14,0	13,0	11,5	13,0	16,5	16,0	15,5	14,0	12,5		9,0	
10,0	13,5	13,3	13,0	11,5	10,5	9,0	12,0	13,5	13,3	13,0	11,5	10,0		10,0	
11,0	11,3	11,1	10,8	9,8	8,8	7,4	11,0	11,4	11,2	10,9	9,7	8,2		11,0	
12,0	9,5	9,3	9,0	8,2	7,2	5,8	10,0	9,6	9,4	9,1	8,1	6,6		12,0	
14,0	7,1	6,9	6,6	5,8	4,8	3,4	7,6	7,2	7,0	6,7	5,7	4,2		14,0	
16,0	5,3	5,1	4,9	4,1	3,2	1,8	5,8	5,4	5,2	4,9	3,9	2,6		16,0	
18,0							4,5	4,1	3,9	3,6	2,6	1,3		18,0	
20,0														20,0	
22,0														22,0	
24,0														24,0	
Passagem	11						9						Passagem		
Gancho	60t												Gancho		
Modo telescópico	I	1	1	1	1	1	2	1	1	1	1	1	2	I	Modo telescópico
	II	1	1	1	1	2	2	1	1	1	1	2	2	II	
	III	1	1	1	2	2	2	1	1	1	2	2	2	III	
	IV	1	1	2	2	2	1	1	2	3	2	2	2	IV	
	V	2	3	2	2	1	1	3	3	2	2	2	1	V	
	VI	3	2	2	1	1	1	3	2	2	2	1	1	VI	

Tabela 1-92 Tabela de capacidade de elevação (apenas com lança principal)

Unidade: tonelada

Estabilizadores totalmente estendidos para 5,3m, contrapeso de 3t, sobre a área de trabalho lateral ou traseira														
RAIO DE TRABALHO (m)	Comprimento de lança (m)												RAIO DE TRABALHO (m)	
	34,2	34,2	34,2	34,2	34,2	34,2 ★	38,4	38,4	38,4	38,4	38,4	38,4		38,4 ★
3,0														3,0
3,5														3,5
4,0														4,0
4,5														4,5
5,0														5,0
5,5														5,5
6,0	19,0	21,5	25,5	26,0	29,0	27,0								6,0
7,0	17,0	19,0	23,0	23,5	22,0	20,5	17,0	20,0	21,5	22,5	22,0	21,5		7,0
8,0	15,5	17,5	19,0	19,0	18,0	16,5	15,5	18,5	19,0	18,5	18,0	17,5		8,0
9,0	14,5	16,0	16,0	15,5	15,0	13,5	14,0	16,5	16,0	15,5	15,0	14,5		9,0
10,0	13,3	13,9	13,4	13,0	12,6	11,1	13,0	13,8	13,3	12,8	12,4	12,0		10,0
11,0	12,0	11,5	11,0	10,7	10,4	8,9	12,0	11,6	11,1	10,6	10,2	9,8		11,0
12,0	10,4	10,0	9,5	9,2	8,9	7,4	10,4	9,9	9,5	9,0	8,6	8,2		12,0
14,0	7,7	7,3	6,9	6,6	6,3	5,0	7,8	7,3	6,9	6,5	6,1	5,7		14,0
16,0	5,9	5,5	5,1	4,9	4,6	3,3	6,0	5,5	5,1	4,7	4,4	4,0		16,0
18,0	4,6	4,2	3,8	3,6	3,3	2,0	4,7	4,2	3,8	3,4	3,1	2,7		18,0
20,0	3,6	3,2	2,8	2,6	2,3	1,0	3,7	3,2	2,8	2,4	2,1	1,7		20,0
22,0							2,9	2,4	2,0	1,6	1,3	0,9		22,0
24,0														24,0
Passagem	8						7						Passagem	
Gancho	60t												Gancho	
Modo telescópico	I	1	1	1	1	1	2	1	1	1	1	1	2	Modo telescópico
	II	1	1	1	1	2	2	1	1	1	2	3	2	
	III	1	1	2	3	2	2	1	2	3	3	2	2	
	IV	2	3	3	2	2	2	3	3	3	2	2	2	
	V	3	3	2	2	2	2	3	3	2	2	2	2	
	VI	3	2	2	2	2	1	3	2	2	2	2	2	

Descrição do Guindaste

Tabela 1-93 Tabela de capacidade de elevação (apenas com lança principal)

Unidade: tonelada

Estabilizadores totalmente estendidos para 5,3m, contrapeso de 3t, sobre a área de trabalho lateral ou traseira														
RAIO DE TRABALHO (m)	Comprimento de lança (m)												RAIO DE TRABALHO (m)	
	42,6	42,6	42,6	42,6	42,6	42,6 ★		46,8	46,8	46,8	46,8	46,8 ★		
3,0														3,0
3,5														3,5
4,0														4,0
4,5														4,5
5,0														5,0
5,5														5,5
6,0														6,0
7,0														7,0
8,0	16,5	17,5	18,0	17,5	16,5	16,0								8,0
9,0	15,0	16,0	15,3	14,9	14,3	13,8								9,0
10,0	13,5	13,5	12,8	12,4	11,8	11,3		13,5	13,0	12,5	11,5	11,0		10,0
11,0	12,0	11,4	10,7	10,3	9,7	9,2		12,1	11,4	10,7	9,9	9,3		11,0
12,0	10,4	9,8	9,1	8,7	8,1	7,6		10,4	9,7	9,0	8,2	7,7		12,0
14,0	7,8	7,3	6,6	6,2	5,6	5,2		7,7	7,0	6,5	5,7	5,2		14,0
16,0	6,0	5,6	4,9	4,5	3,9	3,5		5,9	5,2	4,7	3,9	3,4		16,0
18,0	4,6	4,2	3,6	3,2	2,6	2,2		4,6	3,9	3,4	2,7	2,2		18,0
20,0	3,6	3,2	2,6	2,2	1,6	1,2		3,6	2,9	2,4	1,7	1,2		20,0
22,0														22,0
24,0														24,0
Passagem	6						5						Passagem	
Gancho	60t												Gancho	
Modo telescópico	I	1	1	1	1	2	3		1	1	1	2	3	I
	II	1	1	2	3	3	2		1	2	3	3	3	II
	III	2	3	3	3	2	2		3	3	3	3	2	III
	IV	3	3	3	2	2	2		3	3	3	2	2	IV
	V	3	3	2	2	2	2		3	3	2	2	2	V
	VI	3	2	2	2	2	2		3	2	2	2	2	VI

Tabela 1-94 Tabela de capacidade de içamento (somente com lança principal)

Unidade: tonelada

Estabilizadores meio estendidos para 5,3 m, contrapeso de 3 t, sobre a área de trabalho lateral ou traseira														
Raio de trabalho (m)	Comprimento da lança (m)												Raio de trabalho (m)	
	51,0	51,0	51,0	51,0 ★	55,2	55,2	55,2 ★		59,4	59,4 ★	63,6 ★	70,0 ★		
3,0														3,0
3,5														3,5
4,0														4,0
4,5														4,5
5,0														5,0
5,5														5,5
6,0														6,0
7,0														7,0
8,0														8,0
9,0														9,0
10,0														10,0
11,0	11,5	11,0	10,0	9,2										11,0
12,0	10,0	9,5	8,5	7,8	9,5	8,5	8,0							12,0
14,0	7,4	6,9	6,1	5,4	7,2	6,4	5,7		6,5	6,0				14,0
16,0	5,6	5,1	4,3	3,6	5,4	4,6	3,9		5,0	4,2	4,5			16,0
18,0	4,3	3,8	3,0	2,3	4,1	3,3	2,6		3,7	2,9	3,3	3,3		18,0
20,0	3,3	2,8	2,0	1,3	3,1	2,3	1,6		2,7	1,9	2,3	2,4		20,0
22,0					2,3	1,5	0,8		1,9	1,1	1,5	1,6		22,0
24,0											0,8	0,9		24,0
Passagem	4				3					3		3	3	Passagem
Gancho	60t												Gancho	
Modo telescópico	I	1	1	2	3	1	2	3		2	3	3	4	I
	II	2	3	3	3	3	3	3		3	3	3	4	II
	III	3	3	3	3	3	3	3		3	3	3	4	III
	IV	3	3	3	2	3	3	3		3	3	3	4	IV
	V	3	3	2	2	3	3	2		3	3	3	4	V
	VI	3	2	2	2	3	2	2		3	2	3	4	VI

Tabela 1-95 Tabela de capacidade nominal (com o braço instalado)

Unidade: tonelada

Ângulo da lança (°)	Lança principal + adaptador (m)		Lança principal + braço (m)												Lança principal + adaptador + lança (m)	
	Estabilizadores totalmente estendidos, sobre a área de trabalho lateral ou traseira, contrapeso de 34t															
	63,6+ 9,5	70+ 9,5	63,6+10,4			63,6+17,5			70+10,4			70+17,5			63,6+9,5 +17,5	63,6+9,5 +7+17,5
0°	0°	0°	15°	30°	0°	15°	30°	0°	15°	30°	0°	15°	30°	0°	0°	
80	6,0	4,5	5,5	5,0	4,5	4,0	3,0	2,3	4,5	4,0	3,5	3,0	2,5	2,0	2,0	1,5
78	5,7	4,5	5,5	5,0	4,3	4,0	3,0	2,3	4,5	4,0	3,5	3,0	2,5	2,0	2,0	1,5
76	5,5	4,5	5,3	4,8	4,1	3,7	2,8	2,3	4,2	3,8	3,5	3,0	2,5	2,0	2,0	1,5
74	5,2	4,5	5,0	4,5	3,9	3,5	2,6	2,2	3,9	3,6	3,3	3,0	2,3	2,0	2,0	1,5
72	5,0	4,3	4,5	4,0	3,7	3,3	2,6	2,2	3,6	3,4	3,1	2,8	2,3	1,9	2,0	1,4
70	4,8	4,1	4,0	3,7	3,5	3,1	2,4	2,0	3,3	3,1	2,9	2,6	2,2	1,9	1,9	1,3
68	4,5	3,8	3,7	3,4	3,3	2,9	2,4	2,0	3,0	2,8	2,7	2,4	2,1	1,8	1,8	1,2
66	4,2	3,5	3,5	3,2	3,1	2,7	2,2	2,0	2,7	2,6	2,5	2,2	2,0	1,8	1,7	1,1
64	3,9	3,2	3,3	3,1	3,0	2,7	2,2	2,0	2,5	2,4	2,3	2,0	1,9	1,7	1,6	1,0
62	3,6	2,9	3,1	2,9	2,8	2,5	2,0	1,8	2,3	2,2	2,1	1,9	1,7	1,6	1,5	0,9
60	3,3	2,7	2,9	2,7	2,6	2,3	2,0	1,8	2,1	2,0	1,9	1,8	1,6	1,5	1,4	0,8
58	3,1	2,5	2,7	2,5	2,4	2,1	2,0	1,8	1,9	1,8	1,7	1,6	1,5	1,4	1,3	
56	2,9	2,2	2,5	2,3	2,2	1,9	1,8	1,7	1,7	1,6	1,5	1,4	1,3	1,2	1,2	
54	2,7	2,0	2,3	2,1	2,0	1,7	1,6	1,5	1,6	1,5	1,4	1,2	1,1	1,0	1,1	
52	2,5	1,8	2,1	1,9	1,8	1,7	1,6	1,5	1,4	1,3	1,2	1,1	1,0	0,9	1,0	
50	2,3	1,7	1,9	1,8	1,7	1,5	1,4	1,3	1,2	1,1	1,0	1,0				
48	2,2	1,5	1,7	1,6	1,5	1,5	1,4	1,3	1,0							
46	2,0	1,4	1,6	1,5	1,4	1,3	1,2	1,1								
44	1,8	1,2	1,4	1,3	1,2	1,2	1,1	1,0								
42	1,7	1,0	1,2	1,1	1,0	1,0										
40	1,5		1,0													
Passagem	1															
Gancho	6,5t															

Tabela 1-96 Tabela de capacidade nominal (com o braço instalado)

Unidade: tonelada

Ângulo da lança (°)	Lança principal + adaptador (m)		Lança principal + braço (m)												Lança principal + adaptador + lança (m)	
	Estabilizadores totalmente estendidos, sobre a área de trabalho lateral ou traseira, contrapeso de 23t															
	63,6+9,5	70+9,5	63,6+10,4			63,6+17,5			70+10,4			70+17,5			63,6+9,5+17,5	63,6+9,5+7+17,5
0°	0°	0°	15°	30°	0°	15°	30°	0°	15°	30°	0°	15°	30°	0°	0°	
80	6,0	4,5	5,5	5,0	4,5	4,0	3,0	2,3	4,5	4,0	3,5	3,0	2,5	2,0	2,0	1,5
78	5,7	4,5	5,5	5,0	4,3	4,0	3,0	2,3	4,5	4,0	3,5	3,0	2,5	2,0	2,0	1,5
76	5,5	4,5	5,3	4,8	4,1	3,7	2,8	2,3	4,2	3,8	3,5	3,0	2,5	2,0	2,0	1,5
74	5,2	4,5	5,0	4,5	3,9	3,5	2,6	2,2	3,9	3,6	3,3	3,0	2,3	2,0	2,0	1,5
72	5,0	4,3	4,5	4,0	3,7	3,3	2,6	2,2	3,6	3,4	3,1	2,8	2,3	1,9	2,0	1,4
70	4,8	4,1	4,0	3,7	3,5	3,1	2,4	2,0	3,3	3,1	2,9	2,6	2,2	1,9	1,9	1,3
68	4,5	3,8	3,7	3,4	3,3	2,9	2,4	2,0	3,0	2,8	2,7	2,4	2,1	1,8	1,8	1,2
66	4,2	3,5	3,5	3,2	3,1	2,7	2,2	2,0	2,7	2,6	2,5	2,2	2,0	1,8	1,7	1,1
64	3,8	2,9	3,3	3,1	3,0	2,7	2,2	2,0	2,5	2,4	2,3	2,0	1,9	1,7	1,6	1,0
62	3,4	2,5	2,9	2,8	2,8	2,5	2,0	1,8	2,0	1,9	1,9	1,8	1,7	1,6	1,5	0,9
60	3,0	2,2	2,5	2,4	2,3	2,2	2,0	1,8	1,7	1,6	1,6	1,5	1,4	1,3	1,4	
58	2,6	1,9	2,2	2,1	2,0	1,9	1,7	1,6	1,4	1,3	1,3	1,2	1,1	1,0	1,1	
56	2,3	1,6	1,9	1,8	1,7	1,6	1,5	1,4	1,1			0,9			0,9	
54	2,0	1,3	1,6	1,5	1,4	1,3	1,2	1,2								
52	1,7	1,0	1,3	1,2	1,1	1,1										
50	1,5		1,0													
Passagem	1															
Gancho	6,5t															

Tabela 1-97 Tabela de capacidade nominal (com o braço instalado)

Unidade: tonelada

Ângulo da lança (°)	Lança principal + adaptador (m)		Lança principal + braço (m)												Lança principal + adaptador + lança (m)	
	Estabilizadores totalmente estendidos, sobre a área de trabalho lateral ou traseira, contrapeso de 19t															
	63,6+9,5	70+9,5	63,6+10,4			63,6+17,5			70+10,4			70+17,5			63,6+9,5+17,5	63,6+9,5+7+17,5
0°	0°	0°	15°	30°	0°	15°	30°	0°	15°	30°	0°	15°	30°	0°	0°	
80	6,0	4,5	5,5	5,0	4,5	4,0	3,0	2,3	4,5	4,0	3,5	3,0	2,5	2,0	2,0	1,5
78	5,7	4,5	5,5	5,0	4,3	4,0	3,0	2,3	4,5	4,0	3,5	3,0	2,5	2,0	2,0	1,5
76	5,5	4,5	5,3	4,8	4,1	3,7	2,8	2,3	4,2	3,8	3,5	3,0	2,5	2,0	2,0	1,5
74	5,2	4,5	5,0	4,5	3,9	3,5	2,6	2,2	3,9	3,6	3,3	3,0	2,3	2,0	2,0	1,5
72	5,0	4,3	4,5	4,0	3,7	3,3	2,6	2,2	3,6	3,4	3,1	2,8	2,3	1,9	2,0	1,4
70	4,8	4,1	4,0	3,7	3,5	3,1	2,4	2,0	3,3	3,1	2,9	2,6	2,2	1,9	1,9	1,3
68	4,5	3,5	3,7	3,4	3,3	2,9	2,4	2,0	2,9	2,8	2,7	2,4	2,1	1,8	1,8	1,2
66	4,0	3,1	3,3	3,2	3,0	2,7	2,2	2,0	2,5	2,3	2,2	2,1	1,9	1,8	1,7	1,1
64	3,5	2,7	2,9	2,7	2,6	2,4	2,2	2,0	2,1	1,9	1,8	1,7	1,6	1,5	1,6	0,9
62	3,1	2,3	2,5	2,3	2,2	2,0	1,9	1,8	1,7	1,5	1,4	1,4	1,3	1,2	1,3	
60	2,7	1,9	2,1	1,9	1,8	1,7	1,6	1,5	1,3	1,2	1,1	1,1			1,1	
58	2,3	1,6	1,7	1,6	1,5	1,4	1,3	1,2	1,0							
56	1,9	1,3	1,4	1,3	1,2	1,1										
54	1,6		1,1													
Passagem	1															
Gancho	6,5t															

Tabela 1-98 Tabela de capacidade nominal (com o braço instalado)

Unidade: tonelada

Ângulo da lança (°)	Lança principal + adaptador (m)		Lança principal + braço (m)												Lança principal + adaptador + lança (m)	
	63,6+9,5	70+9,5	Estabilizadores totalmente estendidos, sobre a área de trabalho lateral ou traseira, contrapeso de 15t												63,6+9,5+17,5	63,6+9,5+7+17,5
			63,6+10,4			63,6+17,5			70+10,4			70+17,5				
0°	0°	0°	15°	30°	0°	15°	30°	0°	15°	30°	0°	15°	30°	0°	0°	
80	6,0	4,5	5,5	5,0	4,5	4,0	3,0	2,3	4,5	4,0	3,5	3,0	2,5	2,0	2,0	1,5
78	5,7	4,5	5,5	5,0	4,3	4,0	3,0	2,3	4,5	4,0	3,5	3,0	2,5	2,0	2,0	1,5
76	5,5	4,5	5,3	4,8	4,1	3,7	2,8	2,3	4,2	3,8	3,5	3,0	2,5	2,0	2,0	1,5
74	5,2	4,5	5,0	4,5	3,9	3,5	2,6	2,2	3,9	3,6	3,3	3,0	2,3	2,0	2,0	1,5
72	5,0	4,1	4,5	4,0	3,7	3,3	2,6	2,2	3,5	3,4	3,1	2,8	2,3	1,9	2,0	1,4
70	4,8	3,5	3,9	3,6	3,5	3,1	2,4	2,0	3,0	2,9	2,7	2,5	2,2	1,9	1,9	1,3
68	4,1	3,0	3,4	3,2	3,0	2,9	2,4	2,0	2,5	2,4	2,2	2,1	1,9	1,8	1,8	1,2
66	3,5	2,6	2,9	2,7	2,5	2,5	2,2	2,0	2,0	1,9	1,8	1,7	1,5	1,4	1,5	1,0
64	3,0	2,2	2,4	2,3	2,2	2,0	1,8	1,7	1,6	1,5	1,4	1,3	1,2	1,1	1,2	
62	2,5	1,8	2,0	1,9	1,8	1,6	1,5	1,4	1,2			1,0			1,0	
60	2,1	1,4	1,6	1,5	1,4	1,3										
58	1,7		1,2													
Passagem	1															
Gancho	6,5t															

Tabela 1-99 Tabela de capacidade nominal (com o braço instalado)

Unidade: tonelada

Ângulo da lança (°)	Lança principal + adaptador (m)		Lança principal + braço (m)												Lança principal + adaptador + lança (m)	
	Estabilizadores totalmente estendidos, sobre a área de trabalho lateral ou traseira, contrapeso de 11t															
	63,6+9,5	70+9,5	63,6+10,4			63,6+17,5			70+10,4			70+17,5			63,6+9,5+17,5	63,6+9,5+7+17,5
0°	0°	0°	15°	30°	0°	15°	30°	0°	15°	30°	0°	15°	30°	0°	0°	
80	6,0	4,5	5,5	5,0	4,5	4,0	3,0	2,3	4,5	4,0	3,5	3,0	2,5	2,0	2,0	1,5
78	5,7	4,5	5,5	5,0	4,3	4,0	3,0	2,3	4,5	4,0	3,5	3,0	2,5	2,0	2,0	1,5
76	5,5	4,5	5,3	4,8	4,1	3,7	2,8	2,3	4,2	3,8	3,5	3,0	2,5	2,0	2,0	1,5
74	5,2	4,5	4,8	4,5	3,9	3,5	2,6	2,2	3,5	3,4	3,2	3,0	2,3	2,0	2,0	1,5
72	4,6	3,6	4,2	3,9	3,6	3,3	2,6	2,2	3,0	2,9	2,7	2,5	2,3	1,9	2,0	1,4
70	4,0	3,0	3,6	3,3	3,0	2,9	2,4	2,0	2,5	2,4	2,2	2,1	1,8	1,7	1,9	1,2
68	3,4	2,4	3,0	2,7	2,6	2,5	2,2	1,9	2,0	1,9	1,7	1,7	1,5	1,4	1,5	0,9
66	2,8	1,8	2,4	2,2	2,1	2,0	1,8	1,6	1,5	1,4	1,3	1,3	1,1	1,0	1,2	
64	2,3	1,4	1,8	1,7	1,6	1,6	1,4	1,3	1,1			0,9				
62	1,9	1,2	1,4	1,3	1,2	1,2										
60	1,5		1,0													
Passagem	1															
Gancho	6,5t															

Tabela 1-100 Tabela de capacidade nominal (com o braço instalado)

Unidade: tonelada

Ângulo da lança (°)	Lança principal + adaptador (m)		Lança principal + braço (m)												Lança principal + adaptador + lança (m)	
	Estabilizadores totalmente estendidos, sobre a área de trabalho lateral ou traseira, contrapeso de 3t															
	63,6+9,5	70+9,5	63,6+10,4			63,6+17,5			70+10,4			70+17,5			63,6+9,5+17,5	63,6+9,5+7+17,5
0°	0°	0°	15°	30°	0°	15°	30°	0°	15°	30°	0°	15°	30°	0°	0°	
80	6,0	4,5	5,5	5,0	4,5	4,0	3,0	2,3	4,5	4,0	3,5	3,0	2,5	2,0	2,0	1,5
78	5,6	4,2	5,2	4,8	4,3	4,0	3,0	2,3	4,0	3,7	3,3	3,0	2,5	2,0	2,0	1,5
76	5,2	4,0	4,6	4,0	3,7	3,6	2,8	2,3	3,5	3,1	2,7	2,7	2,3	2,0	1,9	1,5
74	4,3	3,1	3,8	3,3	3,0	3,0	2,6	2,2	2,7	2,4	2,2	2,2	1,8	1,6	1,8	1,3
72	3,5	2,5	3,0	2,6	2,4	2,4	2,1	1,9	2,0	1,8	1,7	1,7	1,4	1,3	1,4	1,0
70	2,8	1,9	2,3	2,0	1,9	1,9	1,6	1,4	1,4						1,1	
68	2,2	1,4	1,6	1,5	1,4	1,4										
66	1,7	0,9	1,1													
64	1,2															
Passagem	1															
Gancho	6,5t															

1.3.6 Gráficos de altura de elevação



Figura 1-15 Gráfico de altura de elevação da lança principal (totalmente estendida) + braço



Figura 1-16 Gráfico de altura de elevação da lança principal + braço

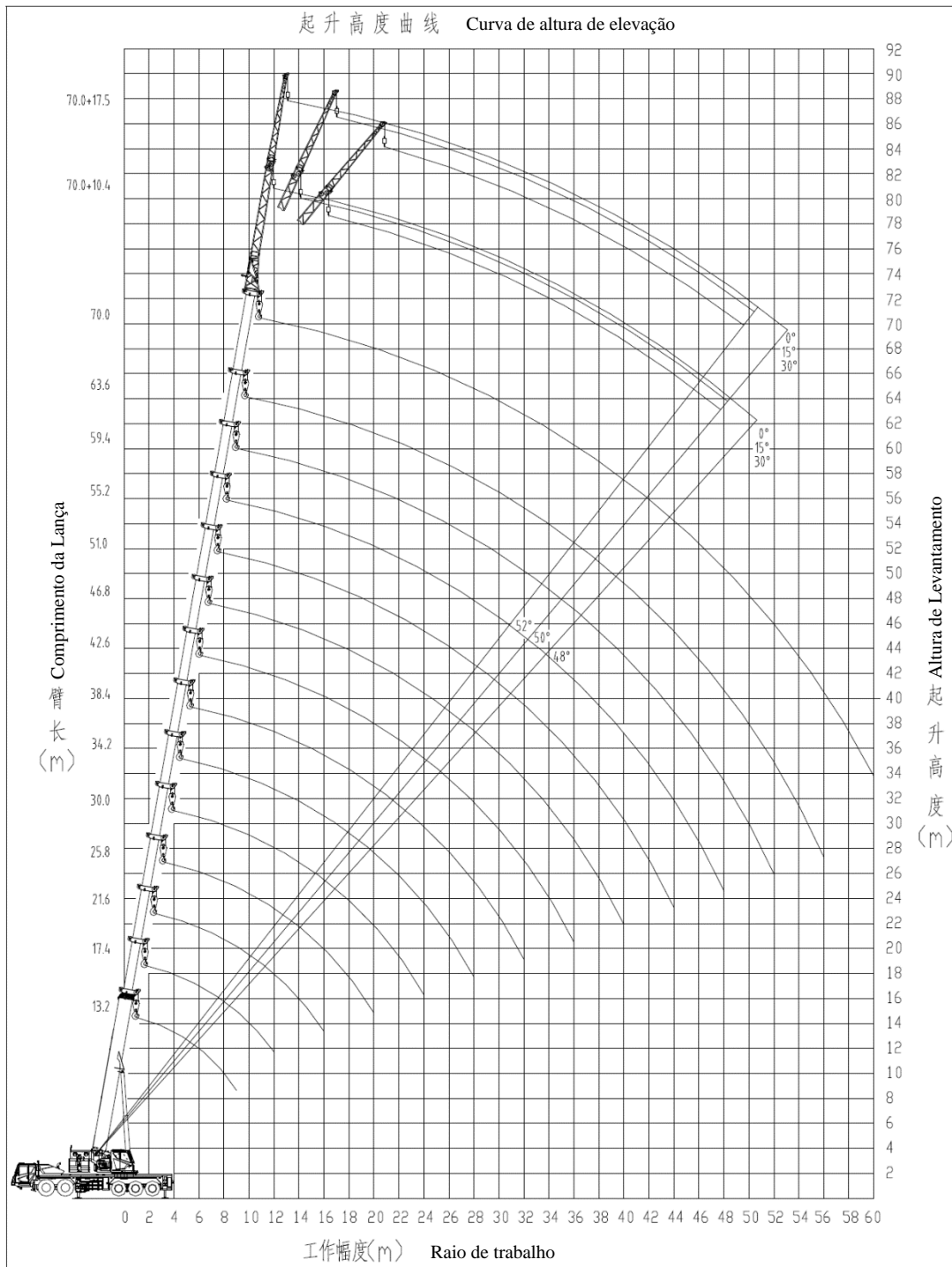

Figura 1-17 Gráfico de altura de elevação da lança principal + lança de ponta

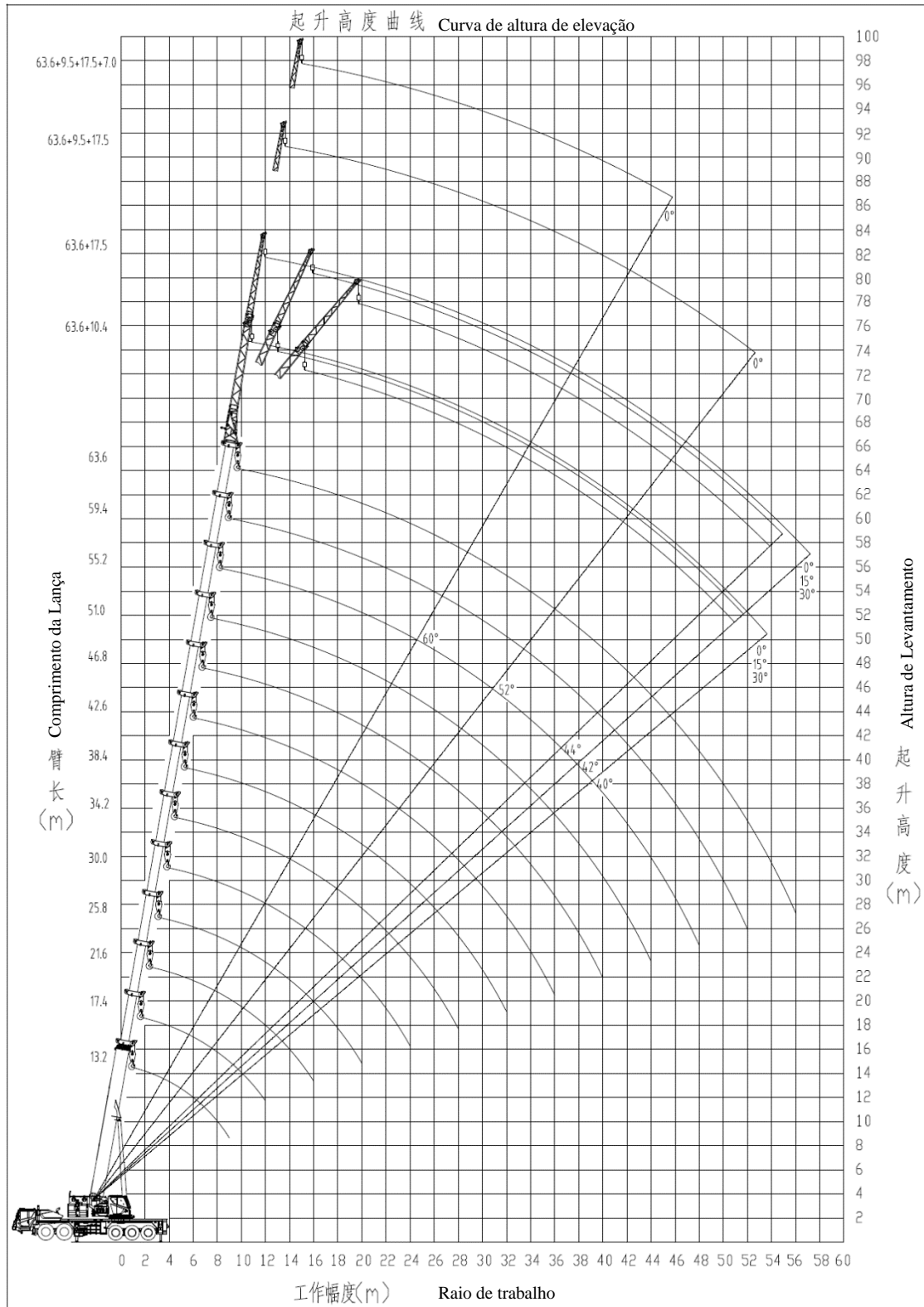

CUIDADO

- (1) As vigas deslizantes dos estabilizadores devem ser estendidas (com um comprimento uniforme em ambos os lados) na medida indicada na tabela de capacidade de elevação. Todas as rodas devem ser levantadas do solo.
- (2) Ao configurar o 5º estabilizador, os valores nas tabelas de capacidade de elevação são adequados para operação de faixa completa de 360°. Estenda o 5º estabilizador ao levantar uma carga pela frente.
- (3) Os valores indicados nas tabelas de capacidade de elevação são os valores máx. capacidades de elevação permitidas em vários OMs e condições operacionais especificadas. Os valores fornecidos nas tabelas incluem a massa do gancho (gancho principal: 670 kg, gancho auxiliar: 200 kg) e eslingas.

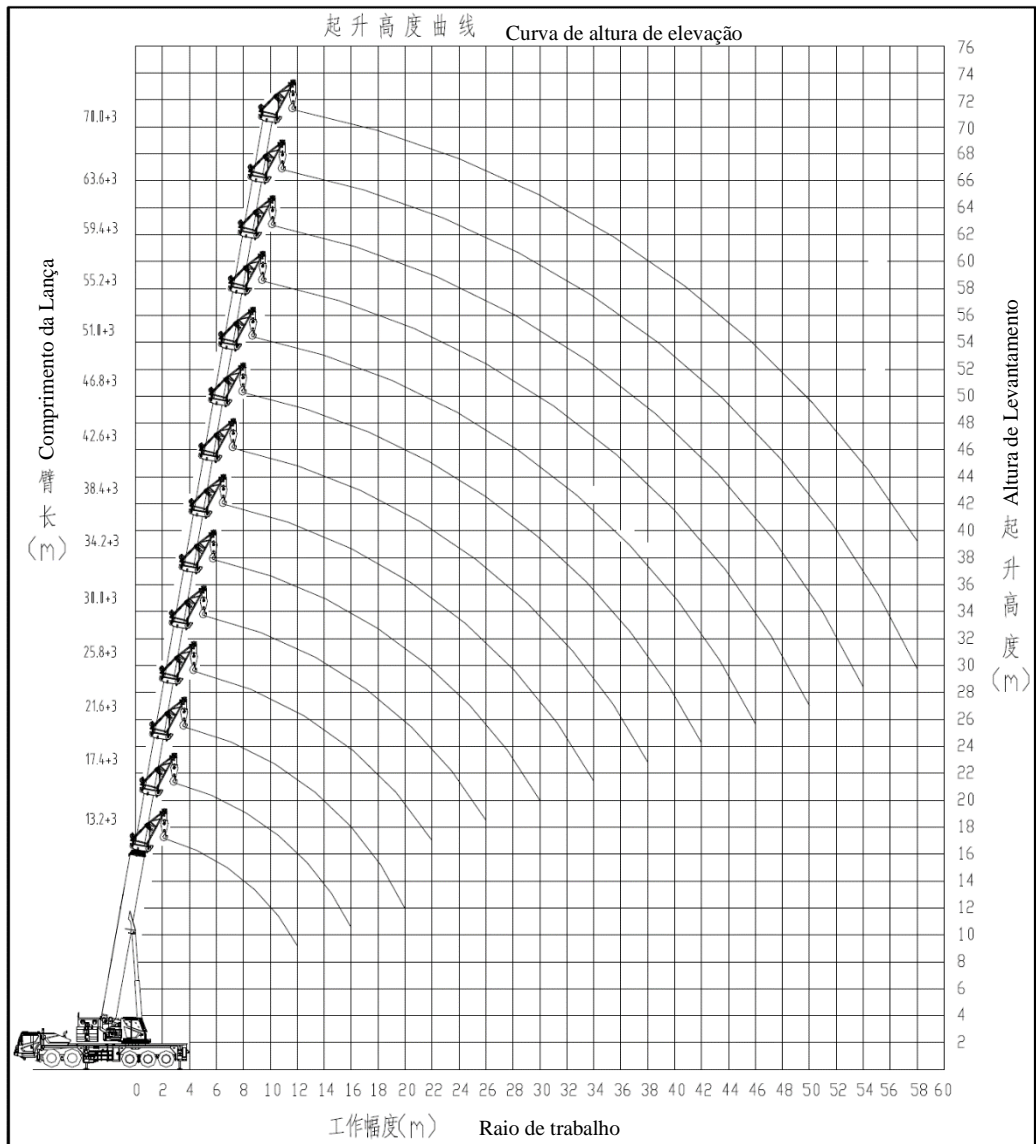

Figura 1-15 Capacidade nominal de elevação

- (4) O raio de trabalho na mesa de capacidade de elevação é medido do centro do gancho até a linha central de giro. Sua unidade é de metros métricos.
- (5) Use a próxima capacidade nominal inferior ao trabalhar no raio entre os números na tabela de capacidade nominal de elevação.
- (6) Os números I, II, III, IV e V na tabela indicam as seções telescópicas correspondentes (número mais alto = seção telescópica mais distante). Os números, 1, 2, 3 e 4, exibem o status da lança do telescópio. 1 representa a extensão do telescópio em 0%, 2 representa a extensão do telescópio em 45%, 3 representa a extensão do telescópio em 90% e 4 representa a extensão do telescópio em 100%.

- (7) A capacidade máxima de elevação nominal para a roldana de caixa aberta é de 6500 kg. Se a capacidade de elevação nominal encontrada na tabela de capacidade de elevação for inferior a 6500 kg de acordo com as condições reais de trabalho, tome o valor na tabela de capacidade de elevação nominal.
- Por exemplo (OM: lança principal totalmente estendida até 70 m, com contrapeso de 34 toneladas): A capacidade de elevação nominal é de 6500 kg quando o raio de trabalho de 18 m.
- A capacidade de elevação nominal é de 4500 kg quando o raio de trabalho de 40 m.
- (8) Durante a operação, não levante uma carga com o gancho principal e o gancho auxiliar simultaneamente.
- (9) Todo o raio de trabalho e altura de elevação nos gráficos de altura de elevação não incluem a deflexão da lança principal e do braço.
- (10) O raio de trabalho do guindaste deve ser estritamente limitado dentro da faixa listada na tabela de capacidade de elevação. Se o raio de trabalho especificado for excedido, o guindaste tombará mesmo sem carga.
- (11) Antes da operação do guindaste, estenda as vigas deslizantes (com um comprimento uniforme em ambos os lados) na extensão indicada nas tabelas de capacidade de elevação. Depois que as vigas deslizantes estiverem em posição, instale os pinos de retenção.
- (12) Antes de iniciar uma operação de elevação, apoie o guindaste nos estabilizadores.
- (13) Nivele o guindaste com a unidade de controle de suporte antes de levantar cargas, examine com frequência e nivele novamente quando necessário durante a operação.
- (14) A capacidade de elevação da lança principal é o valor calculado sem o braço montado.
- Ao usar a lança principal com o braço montado:
2,3 toneladas mais a massa do bloco de gancho e eslingas devem ser subtraídas das capacidades de elevação nominais.
 - Ao usar a lança principal com a lança de ponta montada:
0,5 toneladas mais a massa do bloco de gancho e eslingas devem ser subtraídas das capacidades de elevação nominais.
- (15) Não levante a lança com uma carga suspensa.

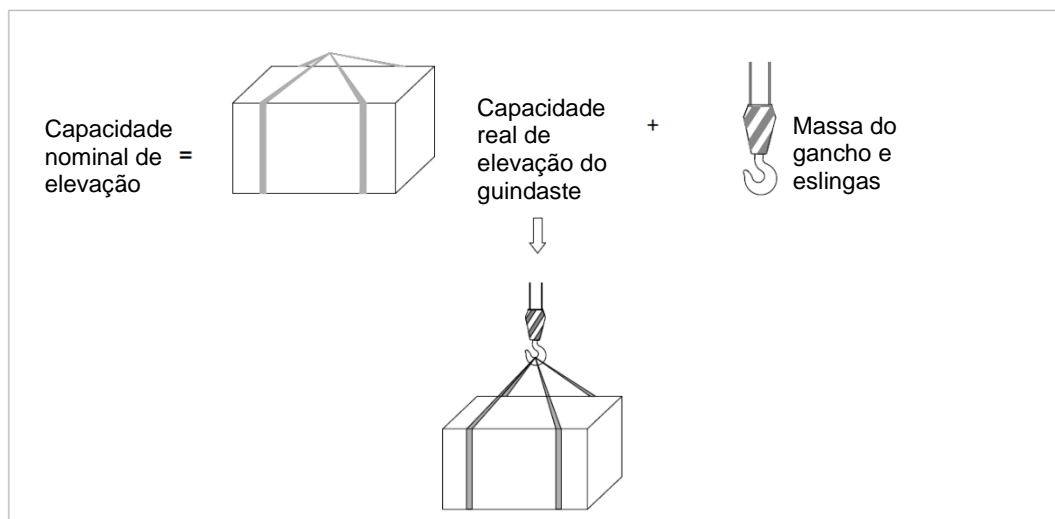

Se a lança principal tiver mais de 30 m de comprimento, fixe a lança de acordo com o gráfico de altura de elevação, mesmo que o guindaste esteja sem carga. Caso contrário, o guindaste pode tombar.

1.3.7 Áreas de trabalho

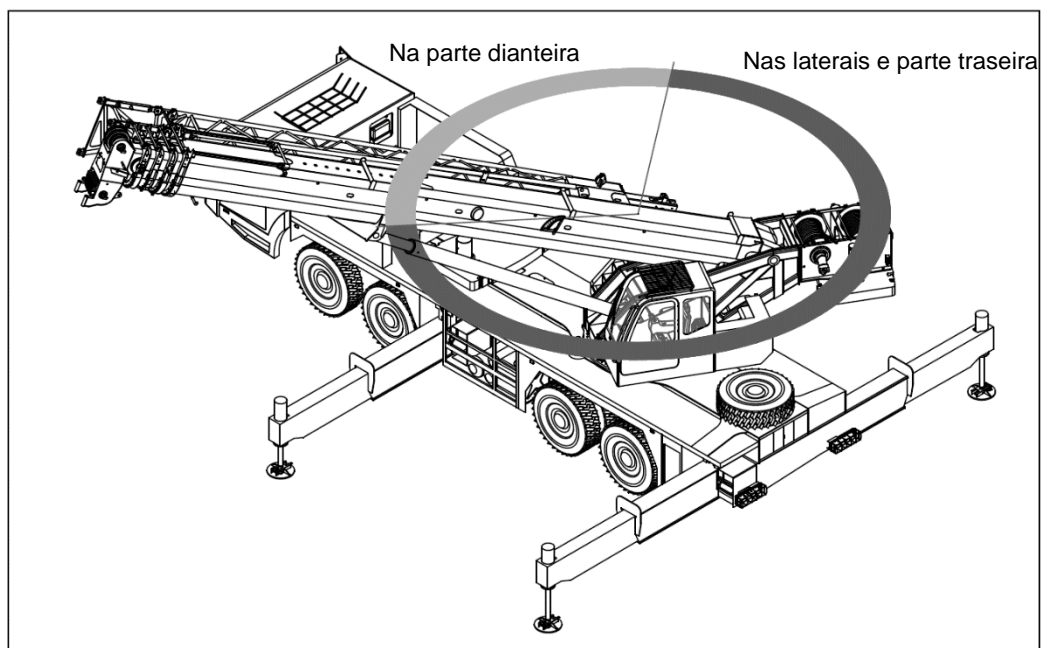
**Figura 1-16** Áreas de trabalho

ZOONLION

Manual do Operador do Caminhão Guindaste

Capítulo 2 Diretrizes de Segurança



Capítulo 2 Diretrizes de Segurança

2.1 Instruções de segurança e sinais de segurança

2.1.1 Instruções de segurança

- Certifique-se de cumprir todos os regulamentos de trânsito nacionais e regionais válidos ao conduzir o guindaste em estradas!
- Ninguém pode permanecer na cabine do operador durante a condução.
- O guindaste deve estar em conformidade com os regulamentos de trânsito locais relevantes antes de ser conduzido em vias públicas, estradas e outros locais. Certifique-se de que os pesos, cargas por eixo e dimensões estejam dentro das licenças especificadas na licença do veículo.
- As pessoas relevantes devem ser treinadas para garantir uma operação segura. O comissionamento inicial e a partida devem ser realizados apenas por uma pessoa competente que tenha lido e entendido completamente as informações fornecidas no Manual do Operador.
- Cumpra os sinais de segurança no guindaste para evitar ferimentos graves ou vítimas.
- Toda a montagem, comissionamento, operação, manutenção e serviço do guindaste devem ser realizados apenas por pessoal especializado.



Não permita que o bloco do gancho prejudique o campo de visão do operador ao conduzir um guindaste em vias públicas!

2.1.2 Sinais de Segurança



- Alguns sinais de segurança que indicam um grande perigo potencial estão apenas colados na carroceria do veículo. Não mova os adesivos aleatoriamente.
- Outro perigo potencial é mencionado neste Manual do Operador. Preste muita atenção nisso.
- Examine os sinais de segurança nas peças potencialmente perigosas em intervalos regulares. Substitua todos os sinais de segurança ausentes ou danificados para se certificar de que os adesivos exibam seu conteúdo.
 - Leia o manual do operador. Este adesivo está colado apenas no painel direito da cabine do operador.



- b) Não levante a lança com uma carga suspensa. Este adesivo está colado apenas no painel direito da cabine do operador.



- c) Saída
Este adesivo está colado apenas no para-brisa dianteiro da cabine do operador.



- d) Não fique embaixo da lança. Este adesivo está preso nas laterais da lança.



- e) Cuidado com o raio de trabalho. Este adesivo está preso nas laterais do contrapeso fixo.



- f) Extintor de incêndio
Fica na lateral da cabine do operador, próximo ao para-lama.



- g) Mantenha-se afastado de estabilizadores em movimento. Este adesivo está preso na viga deslizante.

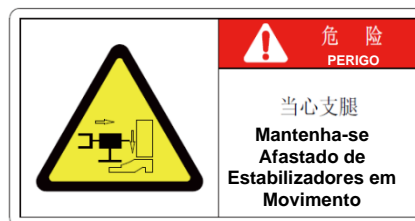

- h) Sempre tranque a porta quando não estiver em uso.

Este adesivo está colado no canto inferior direito do capô esquerdo.



- i) Sem passo
Este adesivo se encontra no teto do capô esquerdo



2.2 Planejando a operação do guindaste

Além de um guindaste funcionando perfeitamente e uma equipe bem treinada, o planejamento da operação do guindaste é um princípio importante da operação segura do guindaste.

O operador do guindaste deve obter ou receber as informações necessárias em tempo hábil antes de se dirigir ao local de trabalho. Em particular:

- a) Ambiente natural do canteiro de obras
- b) Local de trabalho e distância de viagem
- c) Rota
- d) Medidas de folga de altura e largura
- e) Linhas de transmissão elétrica
- f) Restrições de espaço no canteiro de obras
- g) Restrições de movimento causadas por edifícios
- h) Peso e dimensões das cargas a serem içadas e a altura de içamento e raio de trabalho necessários
- i) Condições geológicas ou capacidade de sustentação do solo no canteiro de obras.

Com base nas informações acima, o operador do guindaste deve montar os equipamentos necessários para operar o guindaste:

- a) Gancho de carga/bloco de gancho
- b) Dispositivo de manuseio de carga
- c) Braço
- d) Materiais de base para almofadas de estabilizador.



A operação do guindaste pode não ser possível ou pode ocorrer improvisação se um operador de guindaste não tiver todos os dados necessários.

2.3 Instruções de amaciamento

O objetivo do amaciamento do guindaste é melhorar sua adaptabilidade ao ambiente. A operação adequada de amaciamento pode prolongar a vida útil do guindaste, aumentar a confiabilidade do trabalho e economizar no consumo de energia.

Preste atenção aos seguintes itens durante o período de amaciamento:

- a) Durante a operação inicial do guindaste (menos de 100 horas de operação), você deve seguir as instruções abaixo:
 - A carga de trabalho e a velocidade de trabalho não devem ser muito altas.
 - A capacidade máxima de içamento não deve ser superior a 80% da nominal.
 - Não opere o guindaste a uma velocidade superior aos limites máximos.
- b) Não conduza o guindaste a uma velocidade de condução superior a 55 km/h e com a rotação do motor superior a 1800 r/min nos primeiros 600 km. Conduza o veículo em estrada uniforme.
- c) Aumente a velocidade de condução ou RPM do motor gradualmente após os primeiros 600 km e 2000 km.
- d) Quando o veículo chegar aos primeiros 2.500 km – 3.000 km, substitua o óleo do motor.
- e) Dê partida e desligue o veículo lenta e suavemente. Mude a transmissão com frequência para amaciá-la em todas as marchas.
- f) Amacie as lonas de freio:

Para um desempenho de frenagem ideal, todas as pastilhas de freio novas devem ser amaciadas ativando os freios. Ative os freios bombeando-os em baixa a alta velocidade. A frenagem brusca não é permitida. Em geral, a distância de amaciamento depende do tipo de veículo, mas recomenda-se um mínimo de 500 km. Durante esta fase, a temperatura máxima do cubo do freio ou lonas de freio não pode exceder 200 °C.



Risco de acidente!

O risco de acidente aumenta quando novas lonas de freio são submetidas a uma ou mais operações de frenagem por longos períodos de tempo ou se o veículo for forçado a parar por frenagem brusca a partir da velocidade máxima várias vezes.

A frenagem brusca e a frenagem contínua não são permitidas!

2.4 Diretrizes técnicas gerais de segurança

2.4.1 Requisitos do operador de guindaste, manobrador e sinaleiro

A principal responsabilidade do operador do guindaste, do manobrador e do sinaleiro é controlar, operar, ajustar o guindaste e conduzir a operação de maneira segura para si e para os outros. Muitos acidentes com guindastes são causados pela operação incorreta do guindaste.

Os principais **erros de operação**, cometidos repetidamente durante a operação ou condução de um guindaste, são os seguintes:

- a) Não prestar atenção devida ao trabalho, por exemplo:
 - 1) Girar muito rápido
 - 2) Frenagem rápida da carga
 - 3) Tração na diagonal quando a carga ainda está no solo
 - 4) Afrouxamento dos cabos de aço.
- b) Sobrecarga.
- c) Colisão em pontes, telhados ou fiação de alta tensão devido a folga vertical insuficiente.
- d) Operação inadequada durante o içamento de uma carga com vários guindastes ao mesmo tempo. Cerca de 20% dos danos do guindaste são causados por manutenção inadequada:
 - a) Óleo lubrificante, graxa lubrificante ou anticongelante insuficientes
 - b) Cabo de aço quebrado, peças desgastadas
 - c) Funcionamento incorreto de interruptores de limite ou limitador de momento de carga
 - d) Falha de freio ou transmissão
 - e) Defeitos hidráulicos (ex.: mangueiras rachadas)
 - f) Parafusos soltos.



Tanto para seu interesse quanto para dos outros, certifique-se de entender como seu guindaste funciona e familiarize-se com todos os riscos associados ao trabalho a ser feito.

2.4.1.1 Qualificações gerais do operador

- a) Pessoa treinada e ciente da segurança durante operação do guindaste
- b) Saudável e ágil
- c) Ter uma visão (visão corrigida incluída) acima de 0,7, sem daltonismo.
- d) Ter uma audição qualificada.
- e) Conhecer a possível fatalidade existente na área de trabalho.
- f) Ter capacidade suficiente de avaliar e monitorar a carga.
- g) Ser capaz de corretamente avaliar e monitorar a distância, altura, folga e carga.
- h) Estar familiarizado com o Manual do Operador do guindaste e conhecer o princípio de funcionamento, desempenho de içamento, desempenho estrutural e a função e método

de ajuste dos dispositivos de segurança, bem como dominar os fundamentos da operação e as habilidades de manutenção.

- i) Estar familiarizado com as regras de segurança, sinais e símbolos de segurança.
- j) Ter audição, visão e capacidade de reação qualificadas para o trabalho. Ter o físico necessário para operar o guindaste com segurança. Ser capaz de corretamente estimar a distância, altura e folga.
- k) Saber administrar os primeiros socorros e saber utilizar um extintor. Saber como sobreviver em uma emergência.

Certifique-se de que apenas o pessoal qualificado e autorizado possa operar o guindaste.

AVISO

- (1) O operador deve examinar os freios, bloco de gancho, cabo de aço e dispositivos de segurança antes da operação. Corrija qualquer avaria.**
- (2) O operador deve concentrar sua atenção em seu trabalho durante a operação e está proibido de conversar com outras pessoas. De um modo geral, o operador só pode seguir o sinal enviado por pessoas designadas. Quanto a um sinal de parada, no entanto, o operador deve obedecê-lo em todas as ocasiões, não importa quem o envie. Ele deve se recusar a seguir o sinal que viola os regulamentos de operação. Pare o guindaste imediatamente se alguém for visto subindo no guindaste.**
- (3) O operador que estiver desanimado ou com problemas de saúde não tem permissão para operar o guindaste. Não beba antes da operação.**

2.4.1.2 Qualificações gerais do manobrador

O manobrador é responsável por garantir que a carga seja pendurada ou liberada com segurança e cuidado e decide qual gancho e dispositivo de manuseio de carga será usado de acordo com o plano de trabalho. O manobrador também é responsável pela segurança do guindaste.

Qualificações do manobrador:

- a) Ser certificado para operação do guindaste.
- b) Ter audição, visão e capacidade de reação qualificadas para o trabalho.
- c) Ser capaz de corretamente avaliar e monitorar a distância, altura, folga e carga.
- d) Ter sido treinado no manuseio de carga.
- e) Ser capaz de escolher o gancho adequado e o dispositivo de manuseio de carga de acordo com as condições da carga.
- f) Ter sido treinado em sinais manuais para operação e estar familiarizado com o uso deles.
- g) Ser capaz de usar com segurança equipamentos de áudio (como interfone) para enviar ordens verbais com precisão e clareza.
- h) Certifique-se de que apenas pessoal autorizado possa realizar o trabalho.

2.4.1.3 Qualificações gerais do sinaleiro

O sinaleiro é quem transfere o sinal do manobrador para o operador. Ele tem que conseguir substituir o manobrador para conduzir a operação do guindaste, mas esse trabalho só pode ser feito por uma pessoa a qualquer momento.

Qualificações do sinaleiro:

- Ser qualificado com o trabalho em audição, visão e capacidade de reação.
- Ser capaz de corretamente estimar a distância, altura e folga.
- Ter sido treinado em sinais manuais para operação e está familiarizado com o uso deles.
- Ser capaz de usar com segurança equipamentos de áudio (como interfone) para enviar ordens verbais com precisão e clareza.
- Certifique-se de que apenas pessoal autorizado possa realizar o trabalho.

2.4.2 Escolha de um canteiro de operação

É muito importante escolher um local apropriado para a operação do guindaste para minimizar os riscos de segurança.

Ao escolher o local de colocação do guindaste, observe o seguinte:

- As operações do guindaste podem ser realizadas dentro do raio necessário (raio de trabalho e raio de giro do contrapeso).
- Apoie o guindaste e outras coisas apenas em solo com capacidade de carga suficiente.
- A pressão no solo deve estar de acordo com o valor permitido e esperado embaixo do guindaste com uma carga de içamento necessária.

2.4.2.1 Declives e valas

O guindaste não pode ser instalado muito perto de encostas ou valas. Mantenha as distâncias de segurança adequadas de acordo com o tipo de solo. As fórmulas para cálculo da distância de segurança são as seguintes:

Para solo coesivo macio e não coesivo:

$$A_2 = 2T \quad (1)$$

Para solo coesivo rígido ou semi-sólido:

$$A_1 = T \quad (2)$$

T se refere à profundidade da vala.

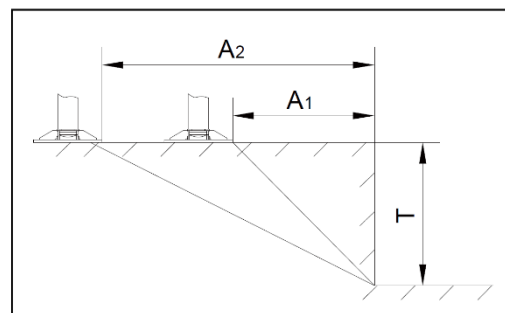

PERIGO

Se a distância de segurança não puder ser mantida, encha e nivele a inclinação e a vala. Caso contrário, o guindaste pode tombar!

2.4.2.2 Pressão de solo permitida do estabilizador

Quando o guindaste estiver apoiado nas estabilizadoras para uma operação de içamento, as estabilizadoras transmitem forças significativas ao solo. Em certos casos, uma única patola deve transmitir quase todo o peso do guindaste, mais o peso da carga, para o solo. O solo deve ser capaz de absorver com segurança essa pressão todas as vezes. Se a área da sapata estabilizadora for inadequada, ela deve ser apoiada de baixo para cima de acordo com a capacidade de sustentação do solo. A fórmula para cálculo da área de apoio exigida é a seguinte:

Área de apoio = força máxima de apoio do guindaste / capacidade de sustentação do solo
A força de pressão de uma variedade de tipos de solo é mostrada na Tabela 2-1, e é apenas para referência.

Tabela 2-1 Capacidade de sustentação de carga do solo

Número de Série	Tipo de solo	Capacidade de sustentação da carga (kg/cm ²)
A	Solo naturalmente compactado e aterrado	0 – 1
	Solo natural, claramente imperturbado:	
B	1. Lama, turfa, solo pantanoso	0
	2. Solo não coesivo, solo em camadas compactamente suficientes Areia de grão fino a médio Areia de grão grosso a cascalho	1,5 2,0
	3. Solo coesivo:	
	Lamacento	0
	Macio	0,4
	Firme	1,0
Semi-compacto	2,0	
Duro	4,0	
C	4. Rocha com poucas fissuras, em estado saudável, intemperizado e em localização favorável: Em ordem de camada coesiva Em forma maciça ou tipo coluna	15 30
	Solo compactado artificialmente:	
C	1. Asfalto	5 – 15
	2. Concreto	
	Grupo de concreto BI	50 – 250
	Grupo de concreto B II	350 – 550

Nota:

Se você não entender algo sobre a capacidade de sustentação da carga do solo no local de instalação, use um instrumento de detecção especial para fazer um teste de solo.



Somente materiais fortes podem ser usados para as bases das sapatas estabilizadoras, como madeiras adequadamente dimensionadas.

Para garantir que a pressão seja distribuída uniformemente sobre a superfície da base, as sapatas estabilizadoras devem ser posicionadas no centro da base de suporte.

2.4.3 Suporte

- Antes da operação, todas as rodas devem ser levantadas do solo.
- Antes de estender o cilindro vertical, estenda as vigas deslizantes para as posições especificadas.
- Estenda todas as vigas deslizantes de acordo com os dados da tabela de capacidade de içamento e fixe-as com pinos.
- Antes da operação, nivele o guindaste. Em qualquer condição de trabalho, o ângulo de inclinação α do guindaste não deve ser superior a $0,6^\circ$. Consulte a Figura 2-1.



Figura 2-1 Ângulo de inclinação do guindaste



Se o guindaste estiver posicionado em uma inclinação e a lança estiver voltada para o declive, o raio conseqüentemente aumentará. É possível que o guindaste tombe em casos extremos.

Assim que o guindaste estiver apoiado, examine as seguintes medidas de segurança:

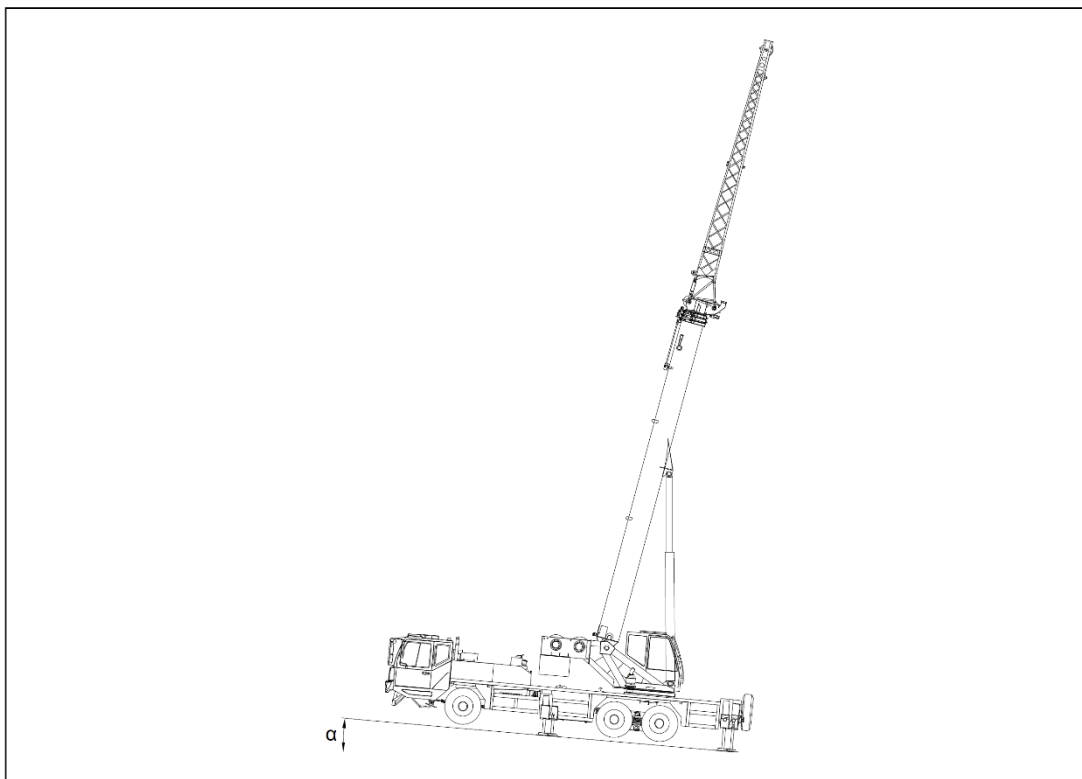
- a) O local de instalação foi selecionado de forma que o guindaste possa ser operado com o menor raio possível.
- b) A capacidade de sustentação de carga do solo é adequada.
- c) Existe uma distância de segurança suficiente para declives ou valas.
- d) Todas as estabilizadoras foram estendidas para a posição especificada.
- e) As estabilizadoras são fixadas com pinos.
- f) As sapatas estabilizadoras estão fixadas.
- g) O guindaste foi nivelado.
- h) Todos os pneus não tocam o solo.
- i) Não há fios elétricos energizados dentro do alcance do guindaste.
- j) Não existem obstáculos que impeçam os movimentos necessários do guindaste.

2.4.4 Condições de trabalho

2.4.4.1 Temperatura

Não opere o guindaste se a temperatura no local de trabalho não estiver na faixa adequada de -20 °C a 40 °C.

AVISO

Fique atento à temperatura ambiente no canteiro de obras.

2.4.4.2 Carga de vento

Antes da operação, meça a velocidade do vento com o anemômetro na cabeça da lança. Ao mesmo tempo, avalie a velocidade instantânea do vento de acordo com o fenômeno físico. A força máxima do vento durante a operação do guindaste é Beaufort 5. Ou seja, a velocidade do vento é de 14,1 m/s e a pressão do vento é de 125 N/m².

2.4.4.2.1 Velocidade do vento

Durante a operação, a velocidade instantânea do vento deve ser considerada como a real. A velocidade do vento durante a operação do guindaste não deve passar de 14,1 m/s. A velocidade do vento durante a operação do guindaste (velocidade do vento instantânea de 3 s) = valor médio da velocidade do vento para 10 minutos de 10 m acima do solo x coeficiente de conversão 1,5.

Para a Beaufort e a velocidade do vento na previsão do tempo, consulte a Tabela 2-2.

Tabela 2-2 Velocidade do vento

Beaufort	Descrição	Velocidade média do vento (m/s)	Velocidade instantânea do vento (m/s)	Efeito do vento na terra
0	Calmo	0 – 0,2	0 – 0,3	Sem vento, a fumaça sobe verticalmente
1	Ar ligeiro(corrente)	0,3 – 1,5	0,5 – 2,3	Direção do vento mostrada pela corrente da fumaça, mas não pelos cata-ventos
2	Brisa leve	1,6 – 3,3	2,4 – 5,0	O vento é sentido no rosto, as folhas farfalham, as palhetas se movem pelo vento
3	Brisa leve	3,4 – 5,4	5,1 – 8,1	Folhas e pequenos galhos em constante movimento, vento estende bandeira levemente
4	Brisa moderada	5,5 – 7,9	8,3 – 11,9	A poeira sobe, pequenos galhos se movem
5	Brisa fresca	8,0 – 10,7	12 – 16,1	Pequenas árvores na folha começam a balançar
6	Brisa forte	10,8 – 13,8	16,2 – 20,7	Galhos grandes em movimento, é difícil usar guarda-chuvas, assobios ouvidos em fios de telégrafo
7	Vento forte	13,9 – 17,1	20,9 – 25,7	Árvores inteiras se movem, difícil de andar contra o vento
8	Vento de força tempestuosa	17,2 – 20,7	25,8 – 31,1	Quebra galhos das árvores, impede o avanço da pessoa
9	Vento tempestuoso	20,8 – 24,4	31,2 – 36,6	Danos estruturais razoáveis (telhas e coberturas de chaminés etc. arrancadas)
10	Vento tempestuoso severo	24,5 – 28,4	36,8 – 42,6	Árvores arrancadas, danos consideráveis ocorrem
11	Tempestade violenta	28,5 – 32,6	42,8 – 48,9	Danos extensos e generalizados da tempestade
12	Furacão	> 32,7	> 49,1	Grande destruição

2.4.4.2.2 Pressão do vento

A operação do guindaste é afetada pela velocidade do vento. Quanto maior a altura acima do solo, mais forte é a velocidade do vento e maior é a pressão do vento.

Pressão do vento = pressão do vento no solo × coeficiente de mudança de altura da pressão do vento

A equação da pressão do vento e velocidade do vento: $p = 0,625v_s^2$. (p representa a pressão do vento, unidade: N/m², v_s representa a velocidade média instantânea do vento, unidade: m/s)

K_h representa o coeficiente de mudança de altura da pressão do vento.

Tome como exemplo a velocidade do vento terrestre de 14,1 m/s. Para a pressão do vento e a velocidade do vento em diferentes alturas, favor consultar a Tabela 2-3.

Tabela 2-3 Velocidades do vento para diferentes alturas acima do solo

Altura acima do solo (m)	≤ 10	10 – 20	20 – 30	30 – 40	40 – 50	50 – 60	60 – 70	70 – 80
K_h	1	1,13	1,32	1,46	1,57	1,67	1,75	1,83
Velocidade do vento v_s (m/s)	14,1	15,03	16,25	17,09	17,72	20,02	20,49	20,96
Altura acima do solo (m)	80 – 90	90 – 100	100 – 110	110 – 120	120 – 130	130 – 140	140 – 150	
K_h	1,90	1,96	2,02	2,08	2,13	2,18	2,23	
Velocidade do vento v_s (m/s)	21,35	21,69	22,02	22,34	22,61	22,87	23,13	



Se a velocidade instantânea do vento for superior ao valor admissível de 14,1 m/s (Beaufort 5), enquanto o guindaste estiver em operação, execute as seguintes tarefas:

- (1) Pare o trabalho (abaixe a carga com segurança).**
- (2) Recolha a lança.**
- (3) Posicione a lança corretamente.**

2.4.4.3 Altura acima do nível do mar

Durante a operação do guindaste, a altura acima do nível do mar não deve ser superior a 2.000 m.

Se a altura acima do nível do mar do canteiro de obras estiver entre 2.000 m e 4.000 m, ative o interruptor de modo terra alta para reduzir a influência de terras altas no guindaste. Para detalhes, favor consultar 3.1.8.1 no Capítulo 3.

Se a altura acima do nível do mar do canteiro de trabalho for superior a 4.000 m, ajuste o guindaste sob medida com antecedência.

Os dados técnicos deste guindaste, como nivelamento e consumo de combustível etc., são aplicados ao local de trabalho cuja altura acima do nível do mar é inferior a 2.000 m.

AVISO

Quanto mais alto acima do nível do mar, menor é a pressão do ar e menor é o teor de oxigênio.

A altura acima do nível do mar é superior a 2000 m, o seguinte desempenho do guindaste será afetado:

- A capacidade de inclinação é reduzida.
- O consumo de combustível aumenta.
- A temperatura de ebulição do líquido de arrefecimento do motor diminui.
- O sistema de escapamento emite fumaça preta.

2.4.4.4 Luz solar direta

Uma diferença de temperatura ocorre entre o lado voltado para o sol e o lado voltado para o lado oposto em guindastes com lanças telescópicas. Isso causa distorção lateral da lança telescópica, o que pode reduzir a capacidade de sustentação de carga da lança telescópica.



Risco de acidente devido a sobrecarga de componentes!

- (1) Se a lança telescópica se deformar devido à luz solar unilateral, isso pode causar sobrecarga dos componentes e, portanto, acidentes.
- (2) Quando uma extensão de lança telescópica, como um braço, estiver sendo usada, o equipamento e o canteiro de obras devem ser inspecionados visualmente antes do recolhimento da carga para assegurar que a lança não apresente sinais de deformação lateral devido ao brilho do sol em um lado. De acordo com a condição do canteiro de obras, ajuste a postura de operação do guindaste. Vire o guindaste diretamente em direção ao sol ou atrás do sol para que ambos os lados da lança fiquem aproximadamente à mesma temperatura, evitando assim deformação lateral!

2.4.4.5 Outras Condições

- a) Durante a operação do guindaste, se a visibilidade for inferior a 200 m, execute as seguintes tarefas:
 - 1) Pare o trabalho (abaixe a carga com segurança).
 - 2) Recolha a lança.
 - 3) Posicione a lança corretamente.
- b) Durante a operação do guindaste, pare de trabalhar em caso de trovoadas ou tempestades. Ao mesmo tempo, tome medidas para evitar raios e trovões para garantir a segurança do pessoal.



Durante a operação do guindaste, pare de trabalhar em caso de trovoadas ou tempestades. Ao mesmo tempo, recolha totalmente e armazene corretamente a lança.

- c) É provável que campos eletromagnéticos fortes estejam presentes se o canteiro de obras estiver próximo a um transmissor. Nesta condição, certifique-se de consultar um especialista em alta frequência ou entre em contato com o revendedor local ou o fabricante.



O campo eletromagnético pode representar perigo direto ou indireto, como efeito nocivo nos órgãos humanos devido à radiação e fazer faísca ou arco elétrico, a pessoas, equipamentos e objetos.

2.4.5 Pontos de atenção para uma operação segura

- a) O pessoal deve ficar longe da área embaixo da lança.

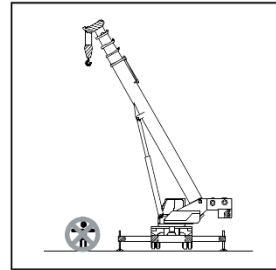

- b) Não deixe ninguém sobre mesa giratória enquanto opera o guindaste.

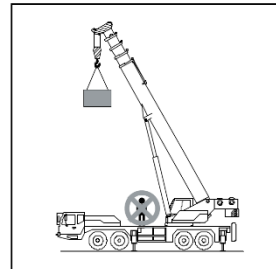

- c) Não transporte pessoas sobre a carga ou outro equipamento usado para içamento.

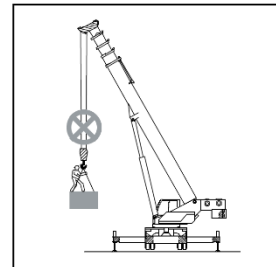

- d) Não mova uma carga acima do pessoal.

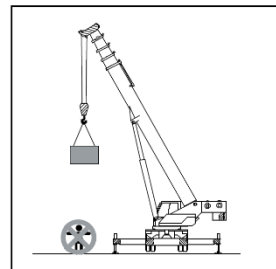

- e) Apoie o guindaste nas estabilizadoras antes da operação.

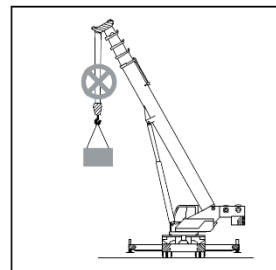

- f) Não levante uma carga que esteja acima da capacidade do guindaste.

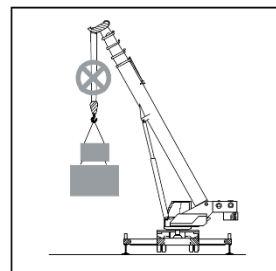

- g) O guindaste, com estabilizadoras estendidas, deve estar no solo com uma inclinação α inferior a $0,6^\circ$ durante a operação.
- h) Não puxe a carga em ângulo e não levante uma carga que não esteja balanceada.
- i) Não tente levantar uma carga enterrada ou congelada no chão.
- j) Quando a carga estiver fora do chão, o operador deve permanecer na cabine.
- k) Não faça a telescopagem da lança com uma carga suspensa.
- l) Não recolha e carregue uma carga.

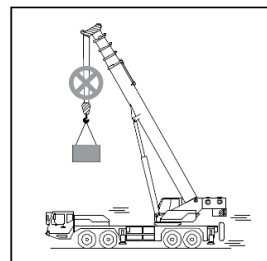
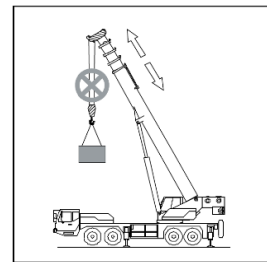
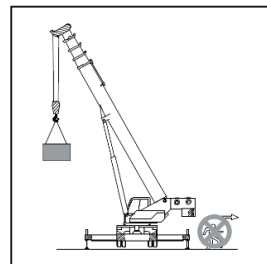
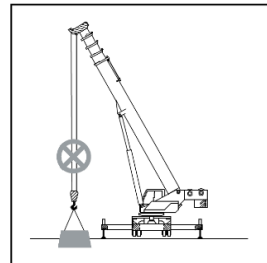
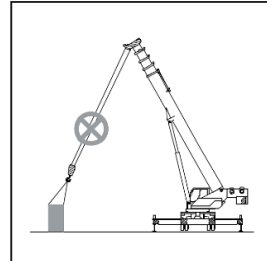
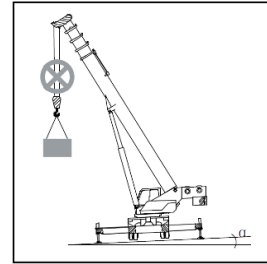

- m) Mantenha uma distância segura quando o canteiro de obras estiver próximo a linhas de energia energizadas. Certifique-se de cumprir os regulamentos relacionados.

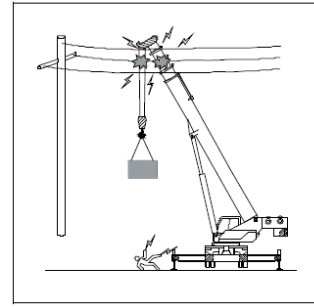

- n) O pessoal deve ficar longe do alcance da lança.
o) Pare o guindaste em caso de emergência.
p) Quando a carga estiver fora do solo, não ajuste o freio da engrenagem da talha.
q) Mantenha pelo menos 3 voltas de cabo de aço no tambor.
r) Antes de operar o guindaste, ajuste as eslingas (cabo ou corrente) para colocar o bloco do gancho na posição vertical do centro de gravidade da carga.
s) Evite que a carga ou o equipamento de içamento colidam com o guindaste.
t) Durante a operação do guindaste, pare de trabalhar em caso de trovoadas ou tempestades. Ao mesmo tempo, tome medidas para evitar raios e trovões garantindo a segurança do pessoal.
u) Antes de iniciar ou parar a operação do guindaste, certifique-se de que as partes móveis e a carga móvel na zona de perigo não interrompam pessoas e objetos.
v) Quando a carga real de içamento atingir 90% da nominal, a luz de aviso acenderá e a campainha soará o alarme. Quando isso ocorrer, cuidado ao continuar o içamento.
w) A operação deve ser estável e suave. Não faça movimentos bruscos com as alavancas. Evite qualquer aceleração ou frenagem repentina ou operação de conversão.

 **PERIGO**

Pare a operação ou não comece a içar uma carga, se ocorrer um dos itens a seguir:

- (1) Uma sobrecarga ou se o peso da carga for desconhecido.**
- (2) O elevador de carga sair da posição, o cordame ficar muito frouxo ou a carga desbalancear.**
- (3) Ausência do material de proteção entre as bordas da carga e o cabo de aço.**
- (4) O nível de luz no canteiro de obras fica abaixo de uma condição de trabalho segura.**
- (5) Avaria do equipamento ou danos ao guindaste que diminuem sua operação segura, como falha do freio e dos dispositivos de segurança ou danos ao cabo de aço.**

2.5 2.5 Sinais manuais

- a) Iniciar
Segure o braço direito esticado verticalmente para cima. A palma está voltada para a frente.

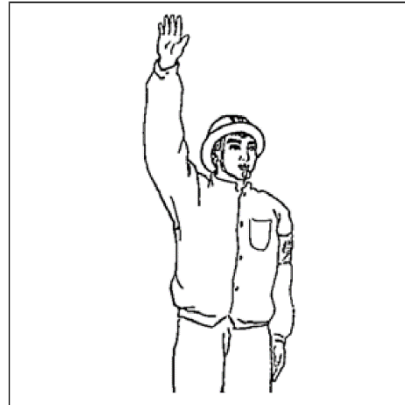

- b) Usar o guincho principal
Bata o punho na cabeça e, em seguida, use o sinal regular.

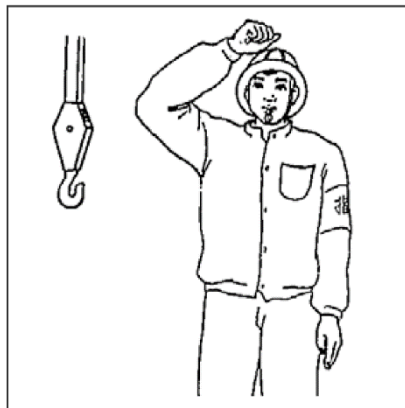

- c) Usar o guincho auxiliar
Toque o cotovelo com uma mão e, em seguida, use o sinal regular.

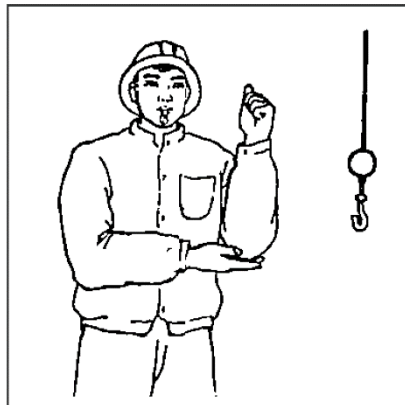

- d) Levante a carga
Com o antebraço na vertical, os dedos estendidos apontando para cima, mova a mão em um pequeno círculo horizontal.

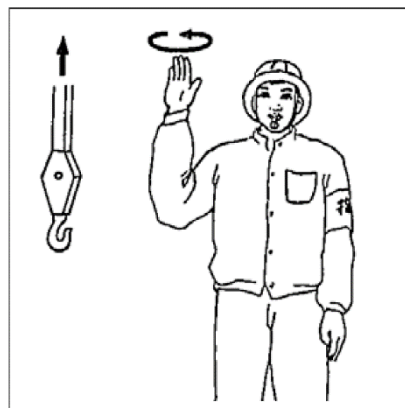

e) Abaixar a carga

Com o braço estendido para baixo em um ângulo de 30° em relação ao corpo, o dedo indicador apontando para baixo, mova a mão em um pequeno círculo horizontal.

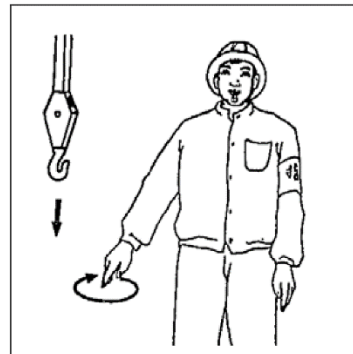

f) Levantar a carga lentamente

Com o antebraço na vertical, palma da mão voltada para cima, acene com a mão para cima repetidamente.

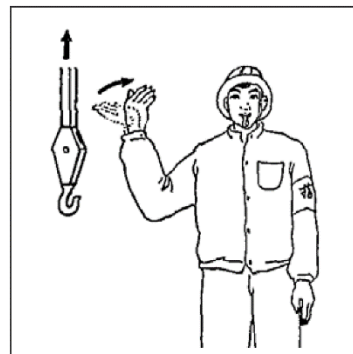

g) Girar

Virar para a esquerda: Com o antebraço direito na vertical, palma da mão voltada para fora, abaixe o antebraço lateralmente na horizontal, dedos apontando no sentido da rotação.

Virar para a direita: Com o antebraço esquerdo na vertical, palma da mão voltada para fora, abaixe o antebraço lateralmente na horizontal, dedos apontando no sentido da rotação.

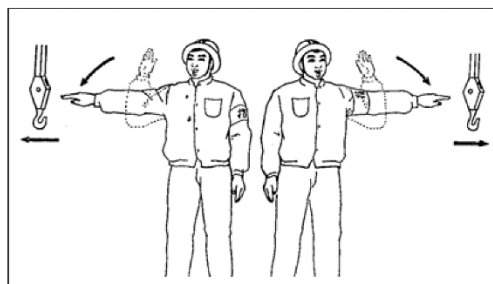

h) Abaixar a carga lentamente

Com o braço estendido para baixo em um ângulo de 30° em relação ao corpo, palma da mão voltada para baixo, acene com a mão para baixo repetidamente.

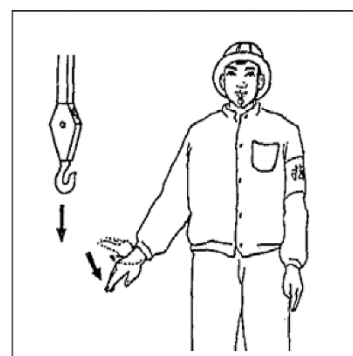

i) Girar lentamente

Virar para a esquerda: Com o antebraço direito na vertical, palma da mão voltada para fora, abaixe o antebraço horizontal e repetidamente, dedos apontando no sentido da rotação.

Virar para a direita: Com o antebraço esquerdo na vertical, palma da mão voltada para fora, mova o antebraço horizontal e repetidamente, dedos apontando no sentido da rotação.

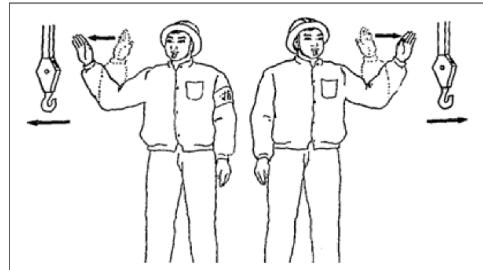

j) Indicar a posição de descida da carga

Estenda os dedos para apontar para a posição em que a carga deve cair.

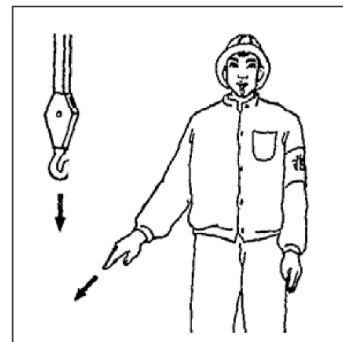

k) Elevar a lança

Braço estendido, dedo fechado, polegar apontando para cima.



l) Abaixar a lança

Braço estendido, dedo fechado, polegar apontando para baixo.

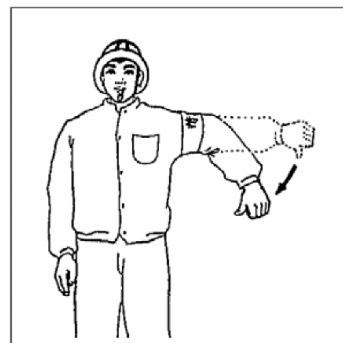

m) Levantar a lança lentamente

O antebraço se estende na frente do corpo com a palma voltada para baixo, outra mão se move para cima e para baixo com o polegar apontando para cima.



n) Abaixar a lança lentamente

O antebraço se estende na frente do corpo com a palma voltada para cima, outra mão se move para cima e para baixo com o polegar apontando para baixo.



o) Estender a lança

Ambos os punhos na frente do corpo com os polegares apontando para fora.



p) Recolher a lança

Ambos os punhos na frente do corpo com os polegares apontando um para o outro.



q) Parar

Braço estendido, palma para baixo, e mova o braço para frente e para trás na horizontal.

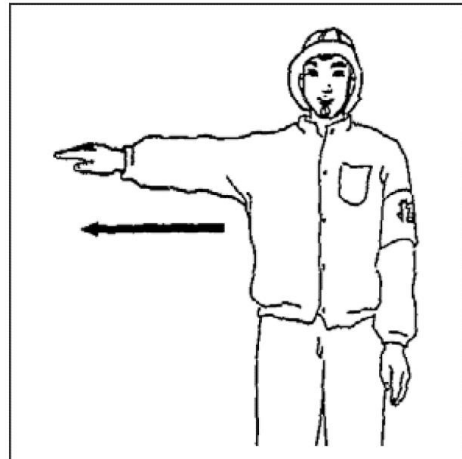

r) Parada de emergência

Ambos os braços estendidos, palmas para baixo, mova os braços para frente e para trás na horizontal.

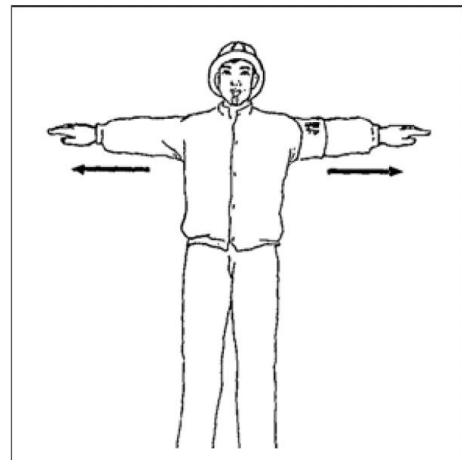

s) Terminar um movimento

Cruze as mãos na frente da testa.

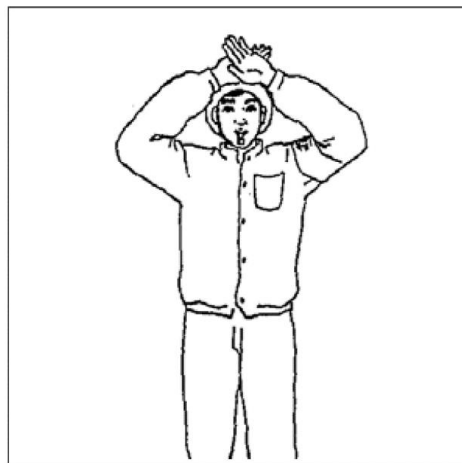

ZOOMLION

Manual do Operador do Caminhão Guindaste **Capítulo 3 Operação - Chassi do Guindaste**



Capítulo 3 Operação - Chassi do Guindaste

3.1 Cabine do operador

3.1. 1 Visão Geral



Figura 3-1 Exterior da cabine

Pos.	Descrição	Pos.	Descrição
1	Suporte do cabo de aço	6	Seta lateral
2	Sinalização giratória ^a	7	Luz de marcação de canto
3	Corrimão	8	Espelho (E)
4	Espelho (D)	9	Limpador de para-brisa dianteiro
5	Maçaneta	10	Sinais de combinação frontal

A parte marcada com "a" é opcional.

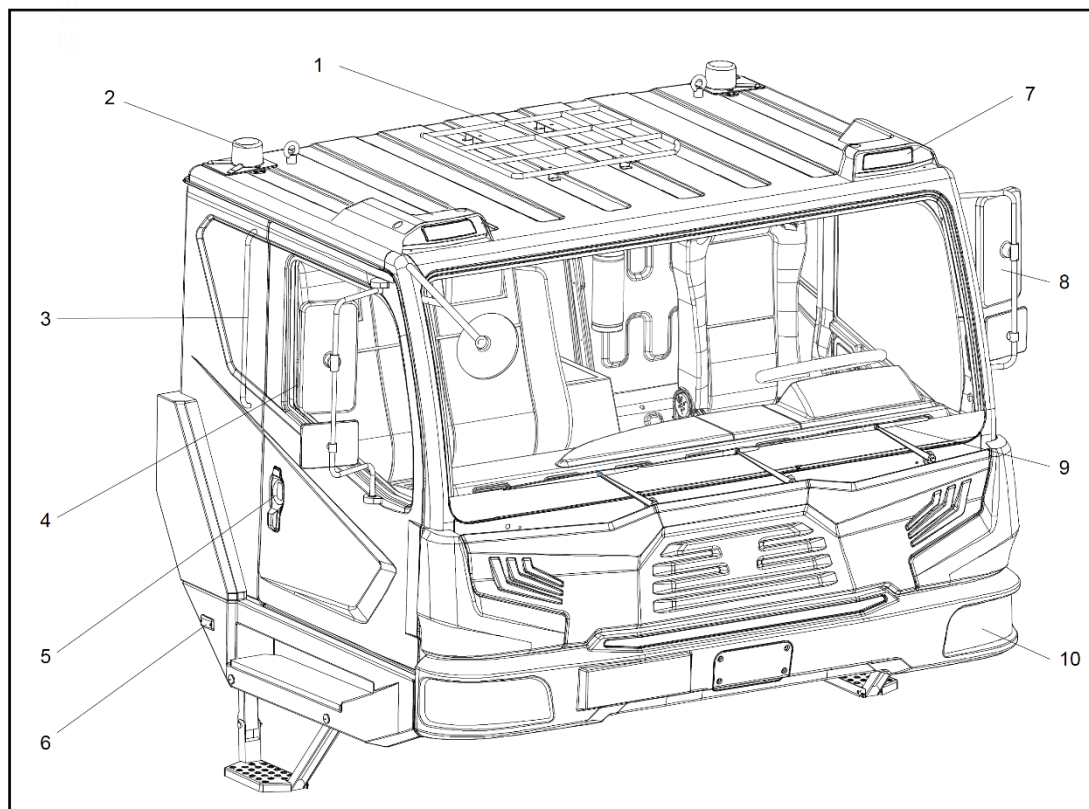

Figura 3-2 Interior da cabine

Pos.	Descrição	Pos.	Descrição
1	Console de instrumentos	10	Local de repouso
2	Conjunto de volante.	11	Assento do operador auxiliar
3	Reservatório de óleo, embreagem (não aplicável ao ATM)	12	Console central
4	Botão da buzina de ar	13	Caixa de controle elétrico central
5	Pedal (E): Embreagem (não aplicável ao ATM)	14	Caixa de ferramentas
6	Pedal (M): Freio de serviço	15	Visor solar
7	Pedal (D): Controle do motor	16	Ventilação do ar condicionado
8	Gabinete de controle elétrico	17	Tela LCD
9	Assento do operador		

3.1.2 Conjunto de volante.

Consulte a Figura 3-3.

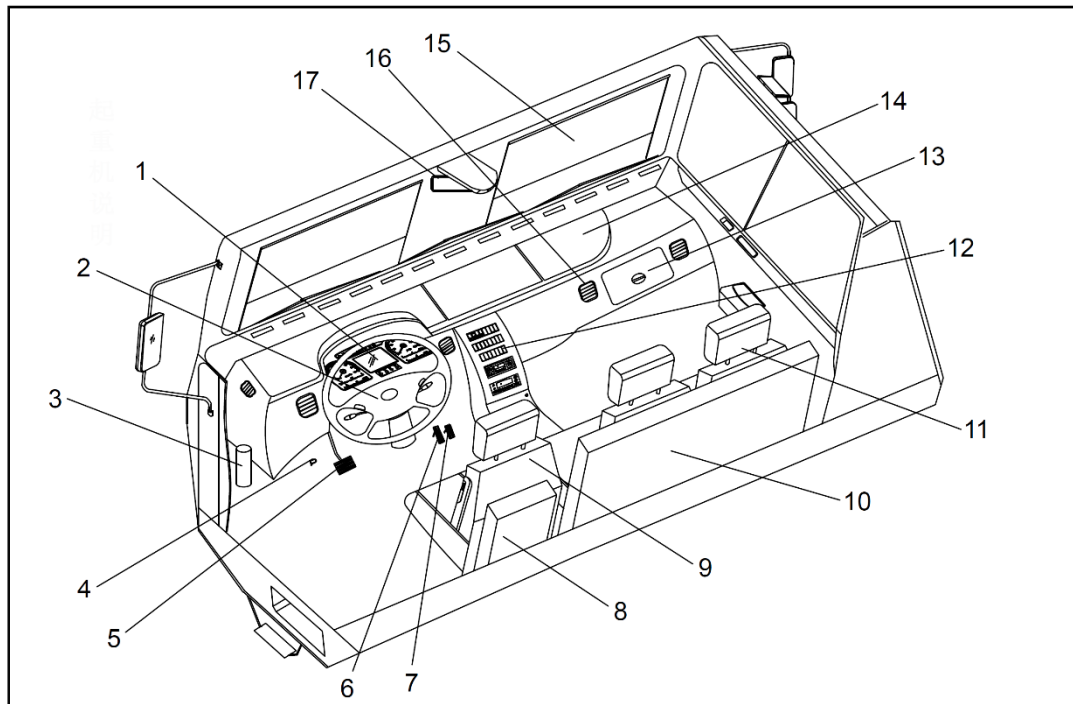

Figura 3-3 Conjunto do volante

Pos.	Descrição	Pos.	Descrição
1	Botão de partida	4	Interruptor da coluna de direção do lado esquerdo
2	Alavanca de ajuste do volante	5	Botões da buzina elétrica
3	Volante	6	Interruptor da coluna de direção direita

3.1.2.1 Alavanca de ajuste do volante

A posição e a altura do volante podem ser ajustadas de acordo com o operador.

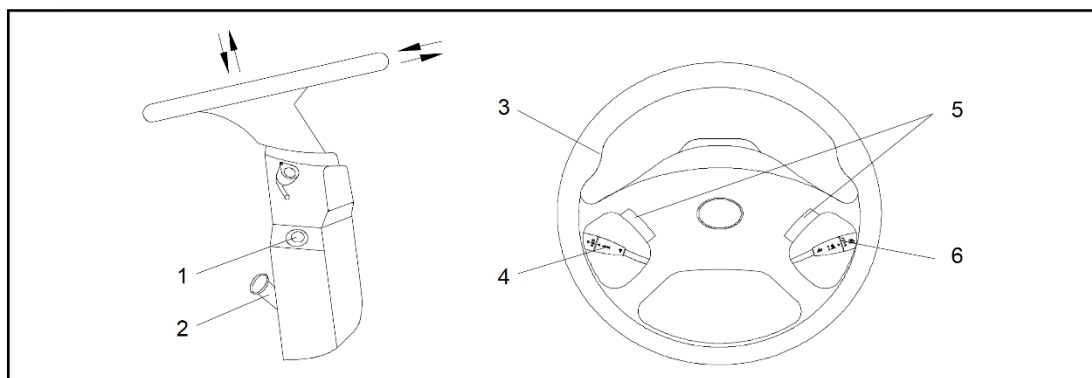
Você pode ajustar a altura e a posição do volante puxando o cabo de ajuste para cima.



- 1) **NÃO** ajuste o volante enquanto move o guindaste. Isso pode te matar.
- 2) **Puxe** a alça para baixo para travar o volante após o ajuste.

3.1.2.2 Interruptor da coluna de direção do lado esquerdo

Consulte a Figura 3-4.



Figura 3-4 Interruptor da coluna de direção do lado esquerdo

- a) Ativação da seta (esquerda / direita)
 Mova o interruptor da coluna de direção para a frente (na direção 1): ative a seta (direita). Mova o interruptor da coluna de direção para trás (na direção 3): ative a seta (esquerda).
- b) Alternar entre o farol baixo e o farol alto e acionar o pisca-alerta
 Mova o interruptor para cima (na direção 2) para ligar o farol alto e o farol. Mova o interruptor para cima e para baixo continuamente para operar o pisca-alerta.
 Não importa em que condições de trabalho as outras luzes estejam, uma vez que o pisca-alerta esteja ligado, o farol acenderá.
- c) Interruptor de luz de perigo
 Pressione a marcação “ \triangle ” (na direção radial 4) no final do interruptor da coluna de direção para ativar as setas esquerda e direita simultaneamente para realizar a função de aviso de perigo. Pressione novamente para resetar.
- d) Ligar a iluminação
 Gire a extremidade do interruptor da coluna de direção para a $\equiv \circ \equiv$ para ativar a luz lateral dianteira, luz lateral traseira, luz de marcação de canto, luz da placa de licença, luz de instrumento operacional e luz de marcação lateral.
 Gire a extremidade do interruptor da coluna de direção para a $\equiv \circ$ posição para ativar o farol alto ou o farol.
- e) Ligar o farol alto
 Mova o interruptor da coluna de direção para a esquerda (na direção 5): ative o farol alto.

3.1.2.3 Interruptor da coluna de direção do lado direito

Consulte a Figura 3-5

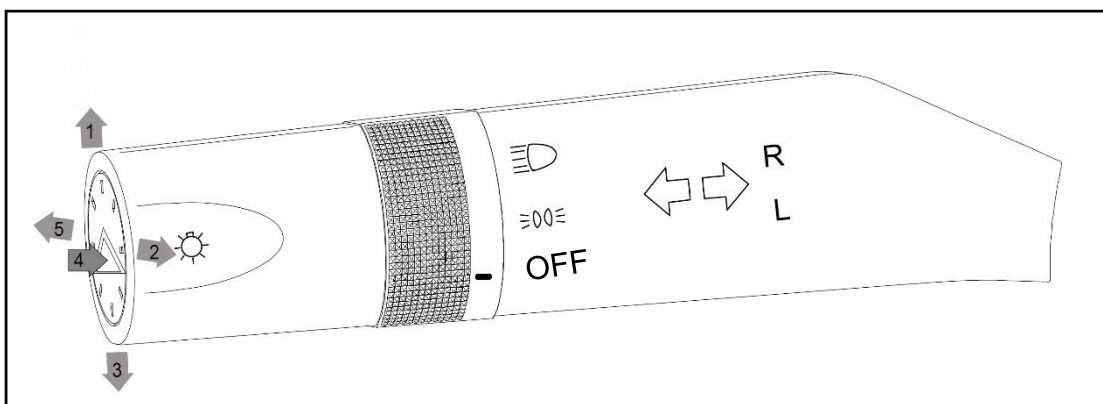

Figura 3-5 Interruptor da coluna de direção do lado direito

- a) Ativar o limpador de para-brisa
- Mova o interruptor da coluna de direção para frente (na direção 1, MIST): ative o limpador de para-brisa e resete automaticamente.
- Mova o interruptor da coluna de direção para trás (na direção 3): realize 4 estágios de limpador de para-brisa.
- HI: Alta velocidade
- LO: Baixa velocidade
- INT: Intermitente
- OFF: Off
- b) Ativar o sistema do lavador e limpador de para-brisa
- Mova o interruptor da coluna de direção (na direção 2). O lavador e o limpador começam a funcionar. Eles não param de funcionar até que o botão seja liberado.

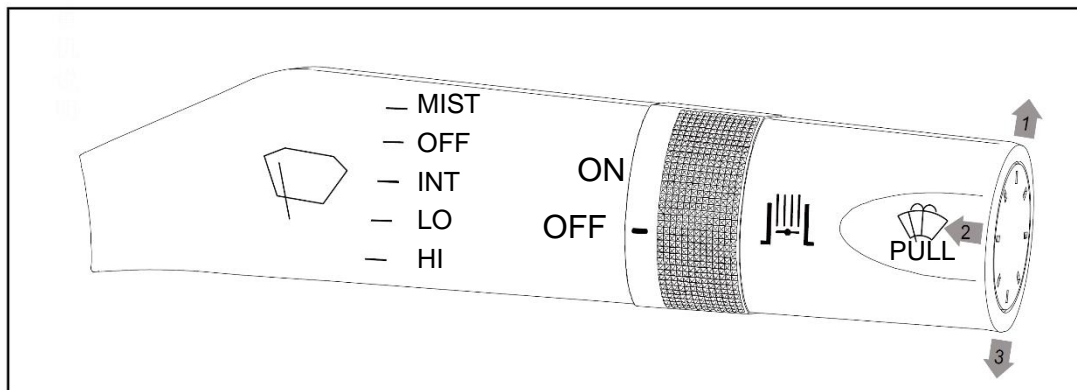

Não opere os limpadores em dias quentes e ensolarados, a menos que você borrife a janela com fluido de limpador. Quando a temperatura estiver abaixo de zero, certifique-se de que as palhetas do limpador não estejam presas na janela antes de ligá-las.

- c) Ativar o freio motor
- Gire a extremidade do interruptor da coluna de direção para a posição "ON" para ativar o freio motor.
- Gire a extremidade do interruptor da coluna de direção para a posição "OFF" para desativar o freio motor.



Você pode pisar no pedal de controle do motor ou no pedal da embreagem para desativar temporariamente o freio motor. O freio de escape do motor continuará seu trabalho depois que você soltar o pedal.

Quando a rotação do motor estiver abaixo de 800 rpm, o freio motor será desativado automaticamente. O freio motor é desativado quando o sistema ABS funciona.

3.1.2.4 Botões da buzina elétrica

Eles estão na área central do volante. Pressione um dos dois botões do lado esquerdo ou direito da área central para ativar a buzina elétrica.

3.1.2.5 Botão de partida

As 4 posições do interruptor (na sequência no sentido horário) são as seguintes:

LOCK Todos os circuitos estão desligados. Você pode conectar ou retirar a chave.

ACC A bateria começa a fornecer eletricidade e partes do sistema elétrico começam a funcionar.

ON Todo o sistema elétrico do chassi é eletrificado.

START Uma posição temporária, use-a para operar o dispositivo de partida. A chave retornará à posição "ON" automaticamente depois que você soltar a chave quando o motor ligar.



Você não pode remover a chave da ignição até que o interruptor esteja na posição **LOCK**.

3.1.2.6 Vidros elétricos

a) Controles ao lado do operador

Interruptor, vidro da porta esquerda

Pressione para a frente:

Os vidros das portas sobem manualmente.

Pressione para trás:

Há duas modos.

Modo 1: os vidros das portas descem manualmente.

Modo 2: os vidros das portas descem automaticamente.

Interruptor, vidro da porta direita

Pressione para a frente:

Os vidros das portas sobem manualmente.

Pressione para trás:

Os vidros das portas descem manualmente.

a) Controles ao lado do operador auxiliar

Interruptor, vidro da porta direita

1) Pressione para a frente:

2) Os vidros das portas sobem manualmente.

3) Pressione para trás:

Os vidros das portas descem manualmente.

Interruptor, vidro da porta esquerda



Interruptor, vidro da porta direita

Plugue



Interruptor, vidro da porta direita

3.1.3 Conjunto do instrumento.

3.1.3.1 Instrumentos



Figura 3-6 Conjunto do instrumento

Pos.	Descrição	Pos.	Descrição
1	Termômetro do refrigerante do motor	5	Indicador de nível de combustível
2	Tacômetro do motor	6	Interface principal
3	Luzes indicadoras	7	Botões operacionais
4	Velocímetro		

1. Termômetro do refrigerante do motor Quando o botão de partida estiver na posição ON, o termômetro do líquido de resfriamento do motor exibe a temperatura do líquido de resfriamento do motor. O ponteiro está localizado no setor branco quando o guindaste estiver operando em condições normais; quando o guindaste estiver sendo conduzido em uma área quente ou em um declive, o ponteiro moverá o setor vermelho direito.

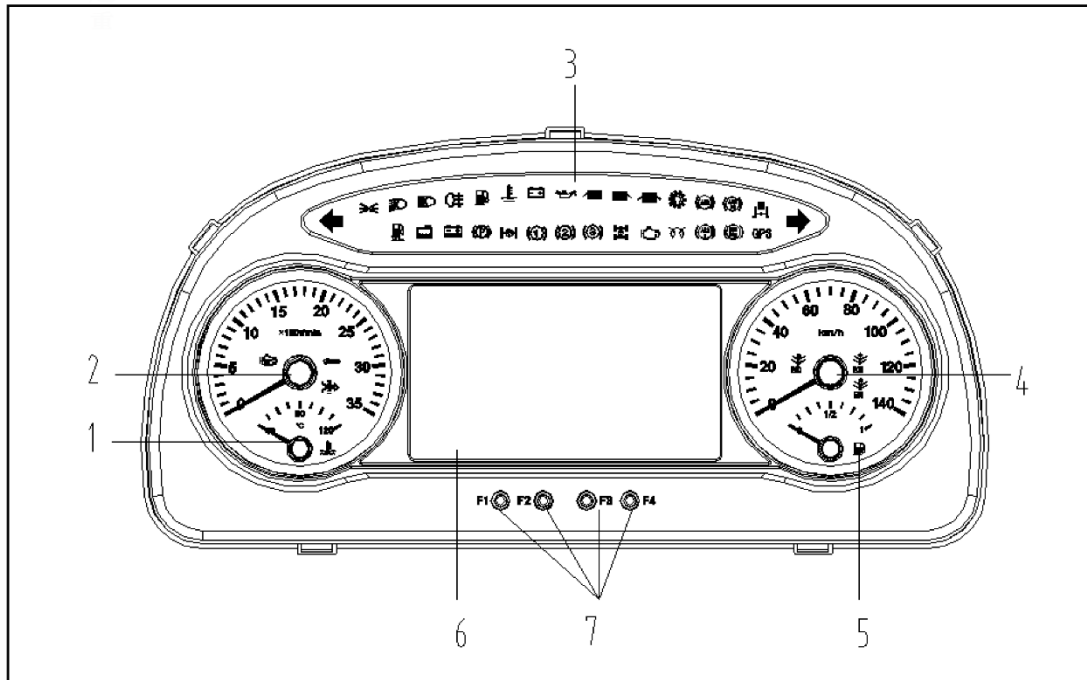
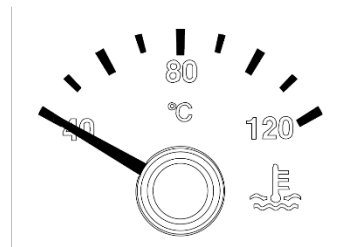

2. Tacômetro do motor

Exibe a velocidade do motor (RPM).

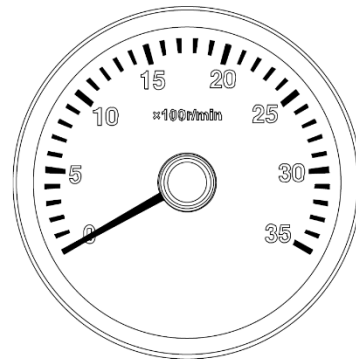
**3. Hodômetro**

Exibe a velocidade do guindaste em quilômetros por hora (km/h)

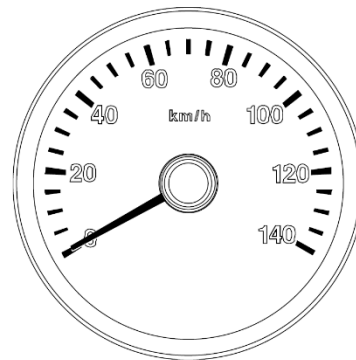
**4. Indicador de nível de combustível**

Exibe o nível de combustível restante no tanque de combustível.

Quando o botão de partida estiver na posição ON, o medidor de combustível exibe aproximadamente o nível de combustível restante no tanque de combustível. “1” indica um tanque cheio enquanto “0” indica um tanque vazio.

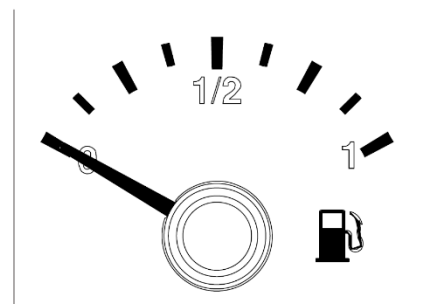

Reabasteça o combustível quando o ponteiro estiver próximo de “0” para garantir a condução normal do guindaste.

3.1.3.2 Luzes de controle



Figura 3-7 Indicações dos instrumentos

Série	Descrição	Série	Descrição	Série	Descrição
1	Luz de aviso Água no óleo	2	Luz de controle Manutenção do chassi	3	Luz de controle Filtro de ar entupido (Não usado)
4	Luz de controle Modo de eficiência de combustível do motor (Não aplicável)	5	Luz de controle Modo ECO do motor (não aplicável)	6	Luz de controle Modo de potência do motor (não aplicável)

1. Luz de aviso Água no combustível acende:

O nível de água no copo coletor do elemento de filtro grosso de combustível excede o limite.

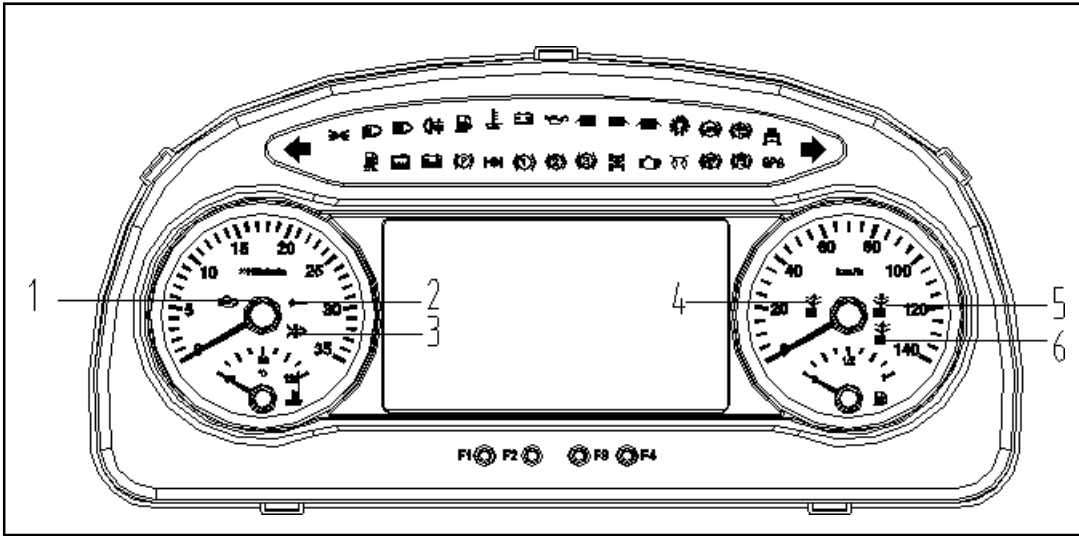
O operador deve descarregar o excesso de água.

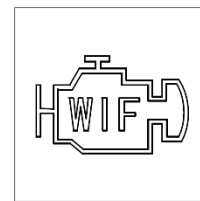

2. Luz de controle Manutenção do chassi Acende:

Há um componente que precisa de manutenção no chassi. Encontre o componente de acordo com o

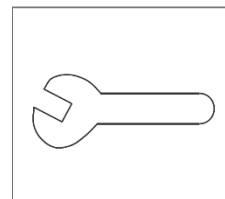

lembrete na tela e confirme após a manutenção.

3. Luz de aviso

Filtro de ar entupido

Não usado.

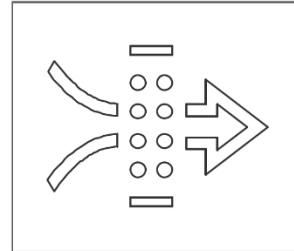

4. Luz de controle

Modo de operação do motor

Não aplicável a este guindaste.



3.1.3.3 Luzes de controle



Figura 3-8 Unidade de exibição

Pos.	Descrição	Pos.	Descrição
1	Luz de controle Direção de deslocamento para a esquerda do veículo	17	Luz de controle Direção de deslocamento para a direita do veículo
2	Luz de controle Iluminação	18	Status do GPS da luz de controle (não usado)
3	Luz de controle Farol baixo	19	Luz de controle Mau funcionamento do diagnóstico do ABS

4	Luz de controle Farol alto	20	Luz de controle Mau funcionamento do ABS 2
5	Luz de controle Luz de neblina traseira	21	Luz de controle Pré-aquecimento do motor
6	Luz de aviso Nível de combustível baixo	22	Luz de controle Mau funcionamento do pós-tratamento do motor (não usado)
7	Luz de aviso Sobretensão do refrigerante do motor	23	Luz de controle Trava do diferencial longitudinal
8	Luz de controle Monitoramento de carga	24	Luz de controle Baixa pressão 3
9	Luz de aviso Baixa pressão do óleo do motor	25	Luz de aviso Baixa pressão 2
10	Luz de aviso Porta esquerda aberta	26	Luz de aviso Baixa pressão 1
11	Luz de aviso Porta direita aberta	27	Luz de controle Trava do diferencial transversal
12	Luz de aviso Portas esquerda e direita abertas	28	Luz de controle Freio de estacionamento aplicado
13	Luz de controle PTO engatada	29	Luz de aviso Subtensão da fonte de alimentação
14	Luz de controle Avaria do ABS	30	Luz de aviso Nível de refrigerante baixo
15	Luz de controle Código de erro ABS exibido	31	Luz de aviso Nível de Adblue baixo
16	Luz de controle Freio motor acionado		

1 Luz de controle

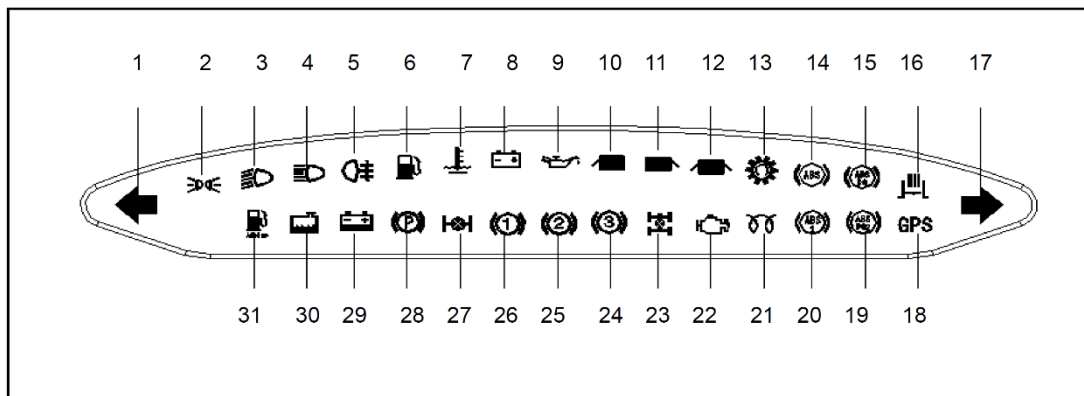
Direção de deslocamento esquerda do veículo Acende:

O veículo deve virar à esquerda.

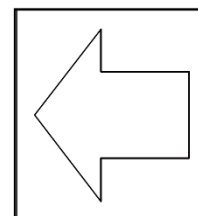

2 Luz de controle Iluminação**Acende:**

O interruptor da coluna de direção do lado esquerdo está girado adiante para a  posição.

Luz lateral dianteira, luz lateral traseira,

luz de marcação de canto, luz de placa de licença, luz de instrumento operacional e luz de marcação lateral também estão LIGADAS.

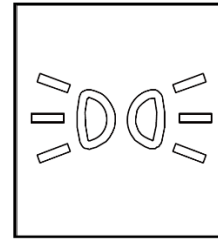
**3 Luz de controle Farol baixo****Acende:**

O farol baixo está LIGADO.

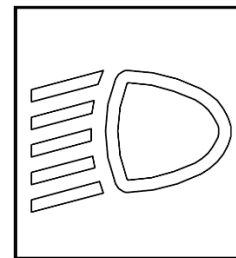
**4 Luz de controle Farol alto****Acende:**

O farol alto ou o pisca-alerta está LIGADO.

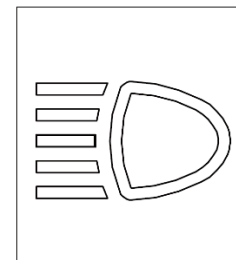
**5 Luz de controle Luz de neblina traseira****Acende:**

A luz de neblina traseira está LIGADA.

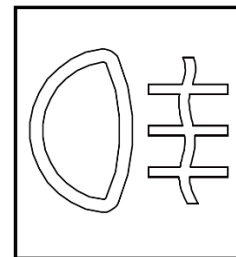
**6 Luz de aviso Nível de combustível baixo**

O nível de combustível é inferior ao valor definido (10%).

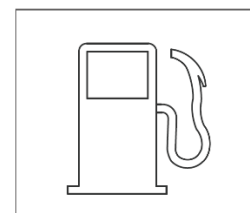

7 Luz de aviso**Temperatura alta do refrigerante do motor****Acende:**

A temperatura do refrigerante do motor é superior ao valor definido (101 °C).

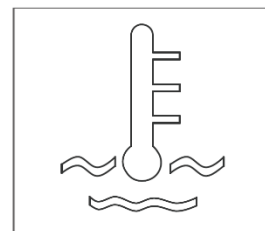
**8 Luz de controle****Monitoramento de carga****Acende:**

O gerador não arranca ou há uma falha no circuito de carga.

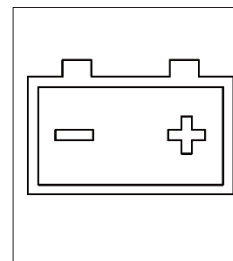
**9 Luz de aviso****Pressão do óleo do motor baixa**

O botão de partida está na posição ON em condições normais.

Apaga:

O motor pega na partida.

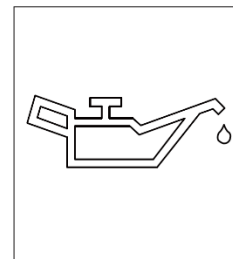

A luz de aviso acende se a pressão do óleo do motor estiver baixa ou o elemento do filtro de óleo do motor estiver sujo. Parar imediatamente o guindaste e rectificar! Caso contrário, o motor será danificado seriamente!

10 Luz de aviso**Porta esquerda aberta****Acende:**

A porta esquerda foi aberta.

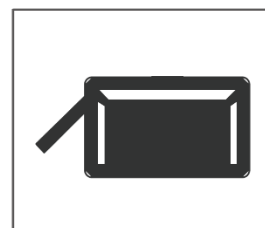

11 Luz de aviso**Porta direita aberta****Acende:**

A porta direita foi aberta.

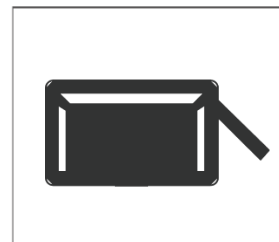
**12 Luz de aviso****Portas esquerda e direita abertas Acende:**

As portas esquerda e direita foram abertas.

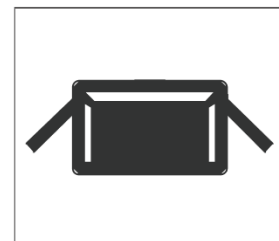
**13 Luz de controle PTO engatada Acende:**

A tomada de força foi engatada.

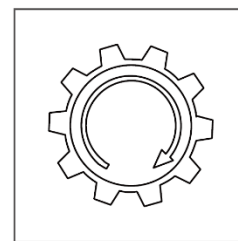
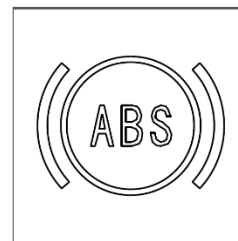
**14 Luz de controle Avaria do****ABS Acende:****Avarias do ABS****15 Luz de aviso****Código de erro ABS****exibido Acende:**

Indica que há uma falha no sistema.

Ligue o interruptor de diagnóstico de falhas do ABS para ler o código flash.

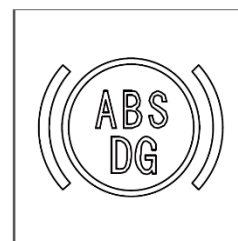
**16 Luz de controle****Freio motor Acende:**

O interruptor do freio motor está pressionado.

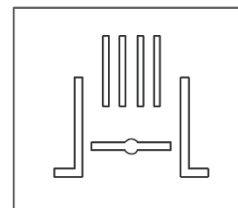

17 Luz de controle

Direção de deslocamento para a esquerda do veículo

Acende:

O veículo deve virar à direita.

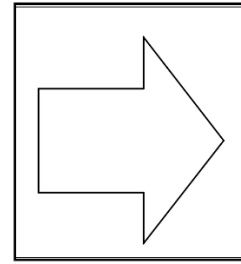
**18 Luz de controle Estado do GPS**

Este veículo não suporta esta função.

**19 Luz de controle**

Avaria do ABS2

Não usado

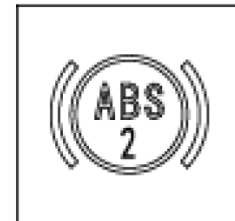
**20 Luz de controle**

Código de erro do ABS2 exibido

Não usado.

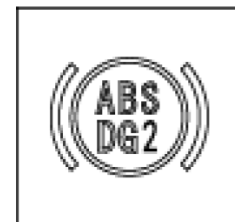
**21 Luz de controle**

Sistema de pré-aquecimento do motor diesel Acende:

O motor está sendo pré-aquecido.

Nota:

O sistema de pré-aquecimento funciona automaticamente e é controlado pela temperatura de entrada de ar do motor.

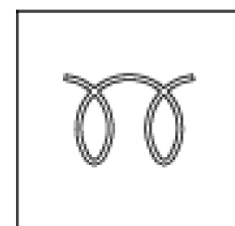

22 Luz de controle

**Mau funcionamento do pós-tratamento do motor
(Não usado)**

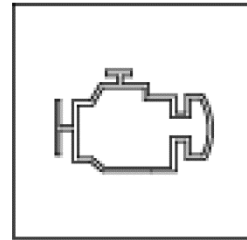
**23****24 Luz de controle**

Trava do diferencial longitudinal Acende:

O botão “Travas do diferencial longitudinal e transversal” é acionado e o diferencial longitudinal é travado.

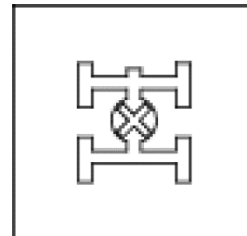
**25 Luz de controle Baixa pressão**

3 Acende:

A pressão do freio de estacionamento é inferior ao valor definido (0,5 MPa).

**26 Luz de controle Baixa pressão**

2 Acende:

A pressão do freio de estacionamento do eixo traseiro é inferior ao valor definido (0,5 MPa).

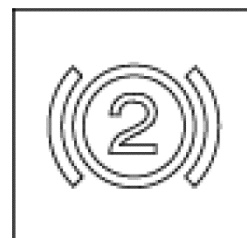

27 Luz de controle Baixa pressão 1 Acende:

A pressão do freio de estacionamento do eixo dianteiro é inferior ao valor definido (0,5 MPa).

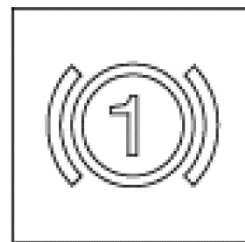
**28 Luz de controle Trava do diferencial longitudinal Acende:**

O botão "Travas do diferencial longitudinal e transversal" acende e o diferencial longitudinal é travado.

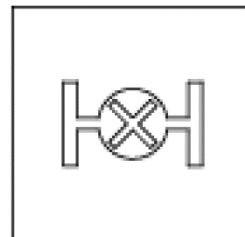
**29 Luz de controle Freio de estacionamento fechado Acende:**

O freio de estacionamento está fechado.
Não dê partida no veículo até que o freio de estacionamento seja liberado e a luz de controle se apague.

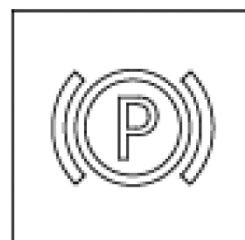
**30 Luz de aviso Tensão de alimentação baixa Acende:**

A tensão da fonte de alimentação é inferior ao valor de configuração de 23V.

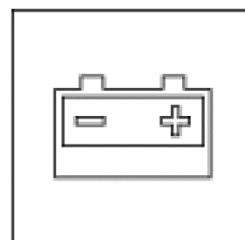
**31 Luz de aviso Nível de Adblue baixo Acende:**

O nível de Adblue é inferior ao valor de configuração de 10%.

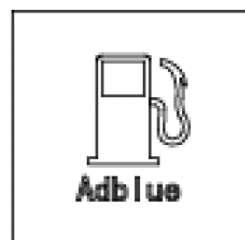

3.1.3.4 Interface principal do instrumento



Figura 3-9 Interface principal do instrumento (para transmissão manual)

Série	Descrição	Série	Descrição	Série	Descrição
1	Milragem total	2	Modo de controle de pressão de ar, suspensão do eixo 5 (manual/automático)	3	Aviso de detecção da lona de fricção esquerdo
4	Aviso de excesso de velocidade	5	Avaria do motor	6	Controle de cruzeiro
7	Avaria da transmissão	8	Sugestão de texto	9	Pressão do ar 1
10	Pressão do ar 2	11	Limite de velocidade	12	Data
13	Hora	14	Sugestão do GPS	15	Temperatura ambiente
16	Indicação do ASR (não usada)	17	Direção hidráulica (não usada)	18	Cinto de segurança do operador não foi travado
19	Velocidade do veículo	20	Cinto de segurança do passageiro não foi travado	21	Aviso de detecção da lona de fricção direita
22	Informações de AMT	23	Subtotal de milragem	24	Número de placas de contrapeso
25	Meta de pressão de ar	26	Nível de Adblue	27	Tensão da bateria
28	Pressão de ar atual, suspensão do eixo 5	29	Indicação de interface (F1, F2, F3, configuração)		

1 Subtotal de milhagem do indicador

Exibe a milhagem dentro do ciclo de condução atual

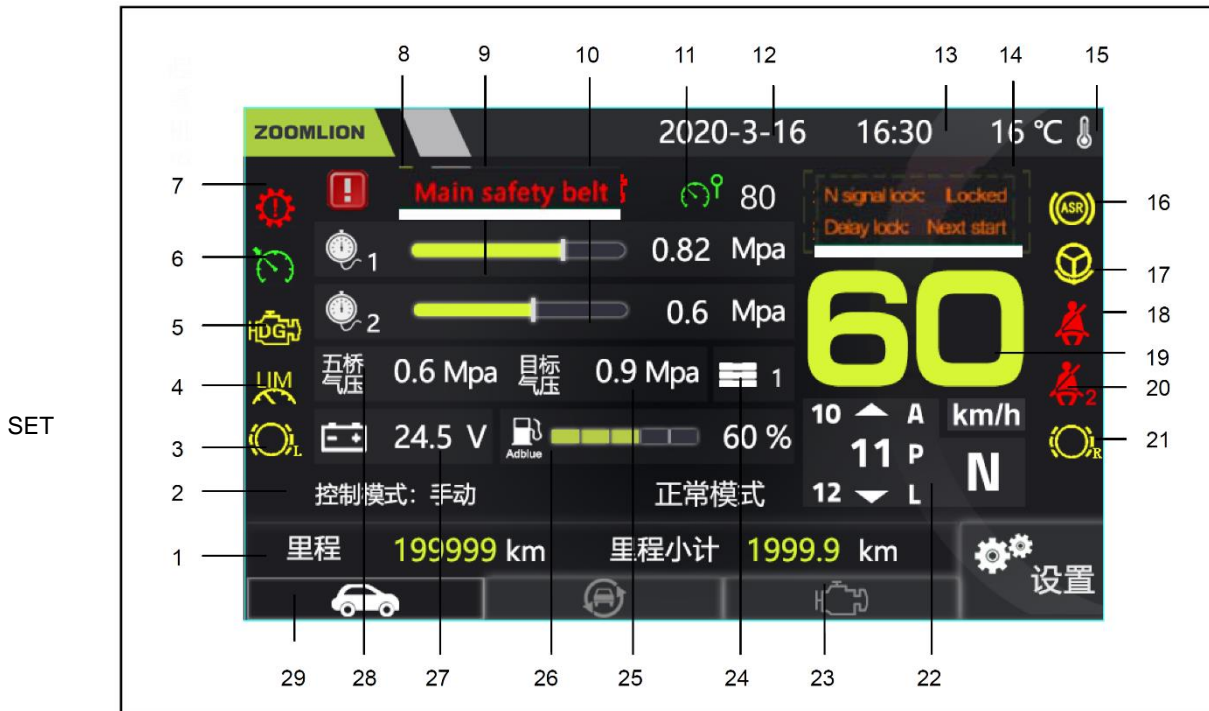
trip 1999.9 km

2 Modo de controle de pressão de ar, suspensão do eixo 5

Os dois modos de controle, ou seja, automático e manual, podem ser alternados usando o interruptor de modo (A/M).

No modo automático, quando a tomada de força não estiver engatada e o freio de estacionamento for aplicado, a chave de 0,5/0,6 Mpa e a chave de pressão de alívio de ar são inválidas. A pressão do ar da suspensão do Eixo 5 é ajustada ao valor alvo de acordo com o contrapeso instalado. Quando a tomada de força estiver engatada ou durante o deslocamento do guindaste, o modo de controle automático é inválido.

No modo manual, quando o freio de estacionamento for aplicado e a tomada de força não estiver engatada, a chave de 0,5/0,6 Mpa e a chave de pressão de alívio de ar são válidas. A pressão do ar da suspensão do eixo 5 pode ser ajustada manualmente.

Nota: quando um pneu opcional 325/95R24 for instalado, o interruptor de carregamento de ar de 0,6 Mpa é inválido.

Ctrl Mode: Manual

3 Aviso**Detecção da lona de fricção esquerda**

Quando a lona de fricção esquerda é detectada como desgastada, este ícone acende.

**4 Aviso****Excesso de velocidade do veículo**

Quando a velocidade do veículo exceder o limite predefinido, este ícone acende.

**5 Indicação de avaria do motor**

Quando houver uma avaria real ou histórica do motor, este ícone acende.

A avaria pode ser verificada na interface de consulta de avaria do instrumento.

**6 Luz indicadora de controle de cruzeiro** Acende quando o motor entra no piloto automático.**7 Luz indicadora de avaria da transmissão (não aplicável à transmissão manual)** Acende quando houver avaria na transmissão. A avaria pode ser verificada na interface de consulta. Vermelho para avarias graves. Amarelo para avarias gerais.**8 Sugestão de texto**

Texto lembrando algumas funções.

Main safety belt

9 Pressão do ar 1

Indica a pressão de ar do sistema de freio do eixo traseiro.



10 Pressão do ar 2

Indica a pressão do ar do sistema de frenagem do eixo dianteiro.



11 Limite de velocidade (corresponde ao contrapeso instalado)

- A velocidade de deslocamento mais alta é limitada a 50 km/h quando duas placas de contrapeso forem instaladas na estrutura do chassi.
- O limite de velocidade é de 90 km/h quando houver uma ou nenhuma placa de contrapeso instalada.
- O limite de velocidade é de 10 km/h quando houver aviso de pressão de ar no painel de instrumentos.



12 Data

Exibe a data atual.

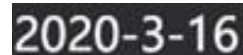

13 Hora

Exibe a hora atual.

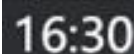

14 Temperatura ambiente

Exibe a temperatura ambiente atual detectada pelo motor.



15 Caixa de sugestão do GPS

Não usado



N signal lock: 100 h
Delay lock: Next start

16 Cinto de segurança do operador não foi travado

Lembra ao operador a necessidade de colocar o cinto de segurança.

**17 Tela digital da velocidade do veículo**

Exibe a velocidade atual do veículo.



60
km/h

18 Cinto de segurança do operador auxiliar não foi travado

Lembra ao operador auxiliar a necessidade de colocar o cinto de segurança.

**19 Aviso****Detecção da lona de fricção direita**

Quando a lona de fricção direita é detectada como desgastada, este ícone acende.

**20 Informações de AMT**

Exibe a posição atual da marcha, a posição da marcha alvo e o modo de trabalho (A-automático, M-manual, E-econômico, P-Energia, L-Baixa velocidade) do AMT.

Indicação do processo de mudança de marcha: Se a posição da marcha alvo

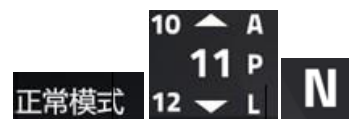

for maior que a atual, o ícone de mudança para cima pisca;

Se a posição da marcha alvo for mais baixa que a atual, o ícone de deslocamento para baixo pisca;

Texto As indicações incluem o seguinte:

- "Modo normal"
- "Auto-aprendizado necessário"
- "Auto-aprendizado iniciado"
- "Motor funcionando"
- "Auto-aprendizado em processo."

21 Subtotal de milhagem

Exibe a quilometragem do ciclo de condução única atual.

A digital display with a black background. The text 'odo' is in white, and '199999 km' is in yellow.

22 Número de placas de contrapeso

Exibe o número detectado de placas de contrapeso, incluindo 0, 1 e 2.

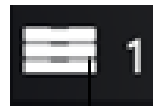

23 Meta de pressão de ar

Exibe a meta da pressão de ar da suspensão do Eixo 5 correspondente ao número atual de placas de contrapeso detectadas na estrutura do chassi.

Quando um pneu opcional 415/80R22 for instalado no Eixo 5, a meta de pressão de ar é de 0,6 Mpa para uma ou mais placas de contrapeso instaladas; e 0,5 Mpa para nenhuma placa de contrapeso instalada.

Quando um pneu opcional

A digital display with a black background. The text 'Target AP' is in white, and '0.9 Mpa' is in yellow.

325/95R24 for instalado, a meta de pressão é de 0,5 Mpa para todas as condições de contrapeso.

24 Nível de Adblue

Exibe o nível atual de Adblue.

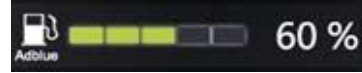

25 Tensão da bateria

Exibe a tensão do gerador quando o motor está funcionando;

Exibe a tensão das baterias quando o motor para de funcionar.



26 Pressão de ar atual, suspensão do eixo 5

Exibe a pressão de ar atual da suspensão do Eixo 5.



3.1.3.5 Interface de instrumento secundário

Pressione a tecla de função F2 para entrar na interface da superestrutura.

Esta interface exibe as horas de trabalho e o subtotal de consumo de combustível etc. da superestrutura.



Figura 3-10 Interface do instrumento secundário

Pos.	Descrição	Pos.	Descrição
1	Horário de funcionamento da superestrutura	5	Consumo médio de combustível de condução
2	Subtotal de consumo de combustível	6	Consumo acumulado de combustível de condução
3	Consumo de combustível acumulado da superestrutura	7	Total de consumo de combustível
4	Consumo médio de combustível da superestrutura	8	Horas de funcionamento do motor

- | | |
|---|--|
| <p>1 Horas de funcionamento da superestrutura Exibe as horas de trabalho acumuladas do motor após a tomada de força ser engatada.</p> | <p>2 Subtotal de consumo de combustível Este valor pode ser zerado pelo usuário e pode ser registrado a partir de 0 a qualquer momento.</p> |
| <p>3 Consumo de combustível acumulado da superestrutura
Exibe o aumento do consumo de combustível após a tomada de força ser engatada.</p> | <p>4 Consumo médio de combustível da superestrutura
Divida o consumo de combustível acumulado da superestrutura pelas horas de trabalho da superestrutura e você obterá o consumo médio de combustível da superestrutura.</p> |
| <p>5 Consumo médio de combustível de condução Divida o consumo de combustível de condução acumulado pela distância total de condução e obtenha o consumo médio de combustível de condução.</p> | <p>6 Consumo acumulado de combustível de condução
Exibe o consumo de combustível acumulado durante a condução.</p> |
| <p>7 Total de consumo de combustível
Exibe o consumo total de combustível registrado pelo motor.</p> | <p>8 Horas de funcionamento do motor
Exibe o total de horas de trabalho registrado pelo motor.</p> |

3.1.3.6 Interface do instrumento de nível 3

Pressione a tecla de função F3 para entrar na interface do chassis.

Esta interface exibe alguns dados do motor. Conforme mostrado na figura a seguir.



Figura 3-11 3ª interface do instrumento

Pos.	Descrição	Pos.	Descrição
1	Abertura do pedal do acelerador do chassis	6	Nível de Adblue
2	Porcentagem de carga	7	Sinal de partida da superestrutura (não usado)
3	Sinal de aceleração estabilizadora	8	Status do sinal da tomada de força
4	Pressão do óleo do motor	9	Abertura do acelerador da superestrutura
5	Parada da superestrutura (Não usada)		

3.1.3.7 Interface de configuração de função do sistema

Pressione F4 na interface principal para entrar na interface de configuração da função do sistema, conforme mostrado na Figura 3-1 2.

Selecione um item manobrando F3 e F4.

Pressione F2 para confirmar e insira uma subinterface.



Figura 3-12 Interface de configuração da função do sistema

- a) A interface de verificação de parâmetros do sistema é mostrada na Figura 3-13.

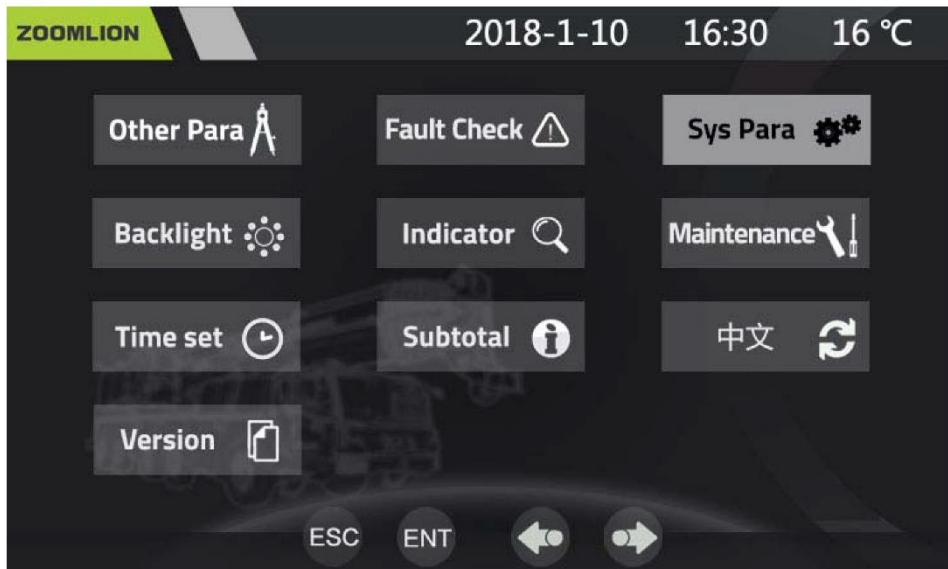

Figura 3-13 Interface de verificação de parâmetros do sistema

- b) A interface de verificação de falhas é mostrada na Figura 3-14. Informações relacionadas à definição do pino do instrumento, avarias do motor, tabela de códigos de problemas do ABS e barramento CAN do instrumento podem ser consultadas nesta interface.



Figura 3-14 Interface de verificação de falhas

- c) Configurações de parâmetros do sistema
Pressione F3 e F4 na interface de função do sistema para selecionar a interface de configuração de parâmetros do sistema.
Pressione F2 para entrar na sub-interface conforme mostrado na Figura 3-15.
Digite a senha para entrar na interface de configuração dos parâmetros do sistema, na qual todos os parâmetros foram predefinidos na fábrica.

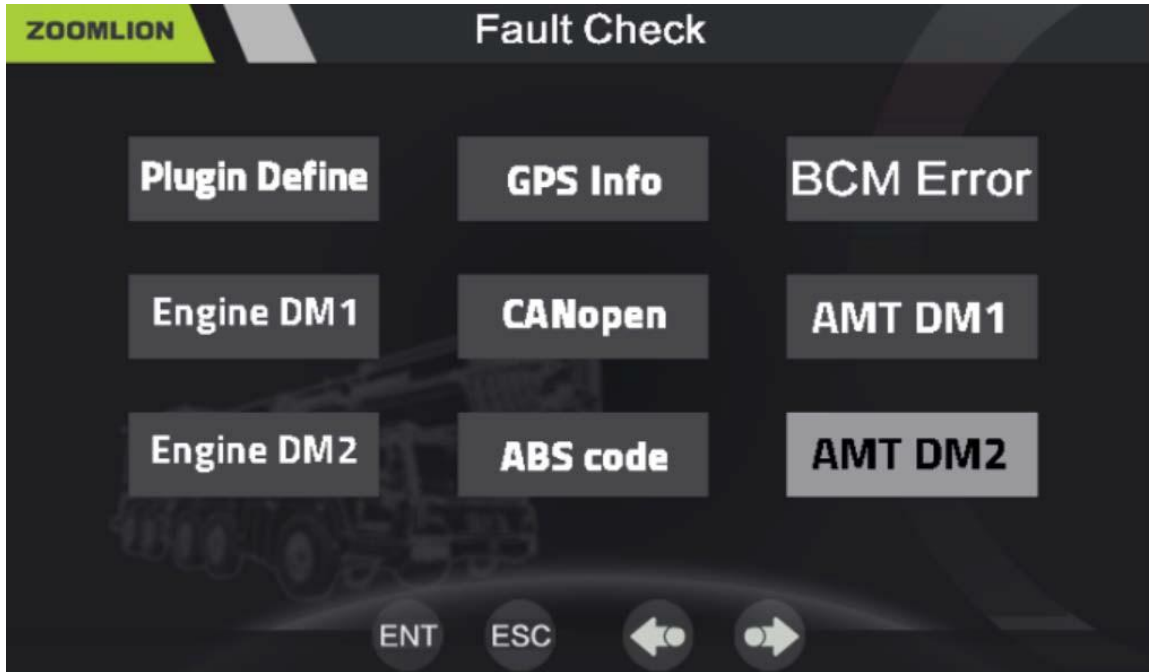

Figura 3-15 Interface de configuração dos parâmetros do sistema

d) Zerando o subtotal de milhagem

Pressione F3 e F4 na interface de função do sistema para selecionar a interface de limpeza do subtotal de milhagem.

Pressione F2 para entrar na subinterface conforme mostrado na Figura 3-16.

Pressione F3 e F4 para selecionar o “Subtotal de combustível” e pressione F2 para zerá-lo.

Pressione F1 para retornar à interface de função do sistema.





Figura 3-16 Interface de zeragem do subtotal de milhagem

e) Interface de informações de manutenção

Quando o ícone  aparecer na interface, entre na interface de informações de manutenção para consultar e confirmar o item de manutenção seguindo os passos abaixo:

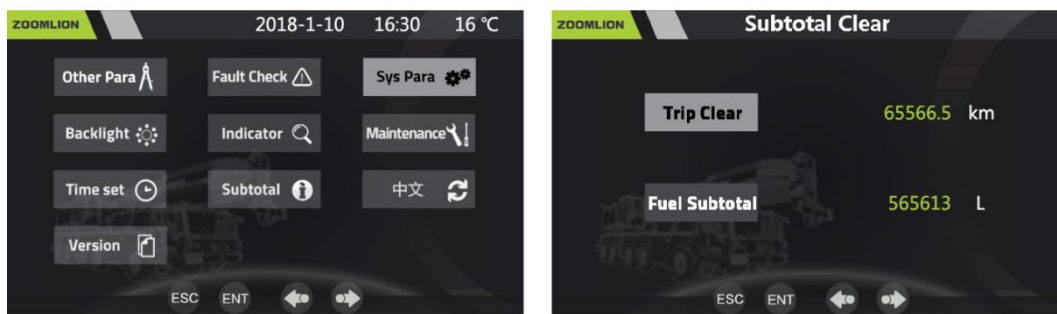
- Pressione F3 e F4 para selecionar o item “Informações de Manutenção” na interface de função do sistema.
- Pressione F2 para confirmar a seleção e entrar na interface conforme mostrado na Figura 3-17.



Figura 3-17 Interface de informações de manutenção

Na interface de informações de manutenção:

- Pressione F3 e F4 para selecionar o item a ser consultado.
 - Pressione F2 para confirmar a seleção e entrar na subinterface do item selecionado.
- f) A interface de consulta do lembrete de manutenção é mostrada na Figura 3-18, que fornece as informações do item que precisa de manutenção no momento.

No	Unit	Event	Engine Hours : 500 H	
			Alert Times	Last Time Alert
1	M And S Engine	Change Engine Oil	2	2017-12-11 12:00
2	M And S Engine	Engine Oil Filter	2	2017-12-11 12:00
3	M And S Engine	Diesel Oil Filter	2	2017-12-11 12:00
6	Transmission	Change Gear Oil	2	2017-12-11 12:00
7	Steering System	Steering Filter	1	2017-12-11 12:00

Figura 3-18 Interface de lembrete de manutenção

Pressione “Requisito de manutenção” na interface de informações de manutenção para entrar na interface de requisito de manutenção, conforme mostrado na Figura 3-19. Ela fornece informações de todos os componentes que precisam de manutenção.

ZOOMLION Maintenance Requirement 3 / 4

NO.	Items	Contents	Maintenance Interval					cycle	
			First 250H	500H	750H	1000H	1250H		
1	Engine	Replace the engine oil.	✓	✓	✓	✓	✓	250H	
		Replace the engine oil filter element.	✓	✓	✓	✓	✓		
		Replace the fuel filter element.	✓	✓	✓	✓	✓		
		Replace the air filter element.		✓		✓			500H
		Replace the engine coolant.				✓			1000H
2	Transmission	Replace the lubricating oil.	✓			✓			
3	Steering system	Replace the hydraulic oil filter element of the steering system.	✓		✓		✓	500H	
		Replace the hydraulic oil of the steering system.				✓		1000H	
4	Brake system	Replace the air dryer filter element.		✓		✓		500H	

ESC ENT ← →

Figura 3-19 Interface de requisito de manutenção

Pressione F3 e F4 para ir para a página seguinte ou anterior.

Pressione F2 para concluir e confirmar a manutenção atual.

- g) As seguintes operações podem ser realizadas na interface de configuração de parâmetros:
 - Ajuste de brilho da luz de fundo;
 - Ajuste do tempo;
 - Consulta de versão de software do instrumento;
 - Consulta de carga do instrumento;
 - Comutação de chinês e inglês.

3.1.3.8 Vídeo de ré e radar de ré (opcional)

A interface principal é exibida quando não há entrada de sinal de reversão.

Quando houver entrada de sinal de ré, vídeo de ré, distância de ré ou a combinação dos dois pode ser selecionada para exibição.

O vídeo de ré só pode ser exibido quando F2 for pressionado na interface de consulta de parâmetros para definir como LIGADO, conforme mostrado na Figura 3-20.



Figura 3-20 Interface de radar de ré + vídeo de ré

A interface do radar de ré é mostrada na Figura 3-21:



Figura 3-21 Tela do radar de ré

A tela de radar de ré + vídeo de ré é mostrada na Figura 3-22:

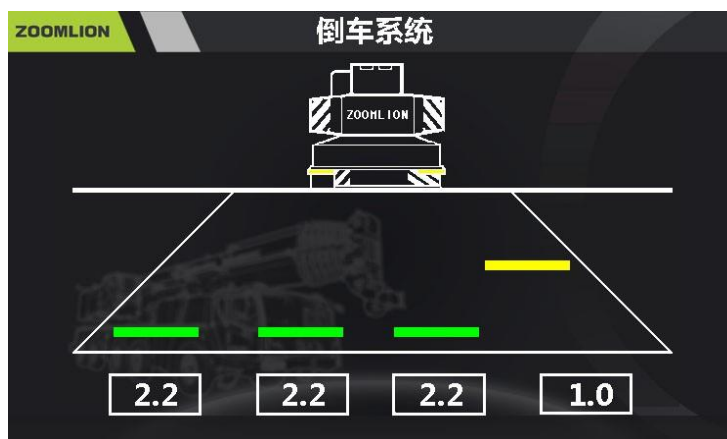

Figura 3-21 Tela de radar de ré + vídeo de ré

3.1.4 Botão da buzina de ar

Está localizado na parte externa do pedal da embreagem e no lado esquerdo do operador.

Abaixado: Alarmes da buzina de ar.

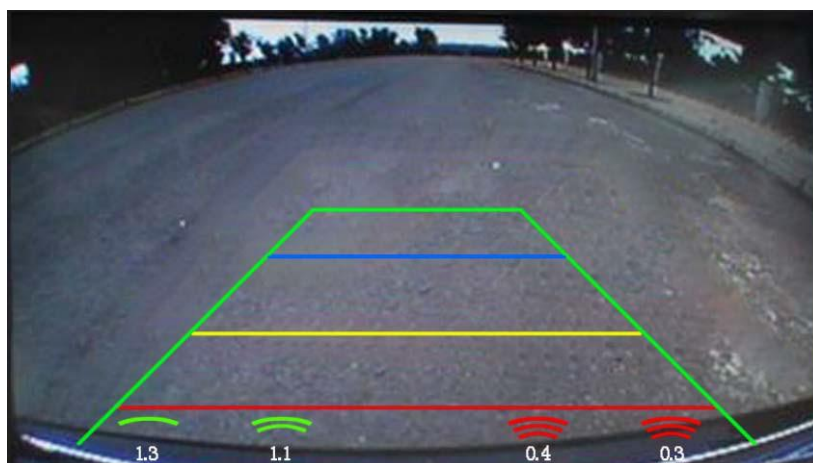
Liberado: Alarmes de paradas da buzina de ar.

3.1.5 Pedal (D): Controle do motor

É um pedal eletrônico.

Abaixado: o veículo acelera. Liberado: o veículo desacelera.

3.1.6 Pedal (M): Freio de serviço

Abaixado: o veículo desacelera ou para.

3.1.7 Pedal (E): Embreagem (não aplicável ao AMT)

Abaixado: a embreagem está desengatada.

3.1.8 Console central



Figura 3-24 Console central

Pos.	Descrição	Pos.	Descrição
1	Teclado	4	Alavanca de câmbio (AMT ou MT)
2	Reprodutor de mídia	5	Alavanca do freio de estacionamento
3	Painel de controle, A/C e aquecedor da cabine		

3.1.8.1 Teclado

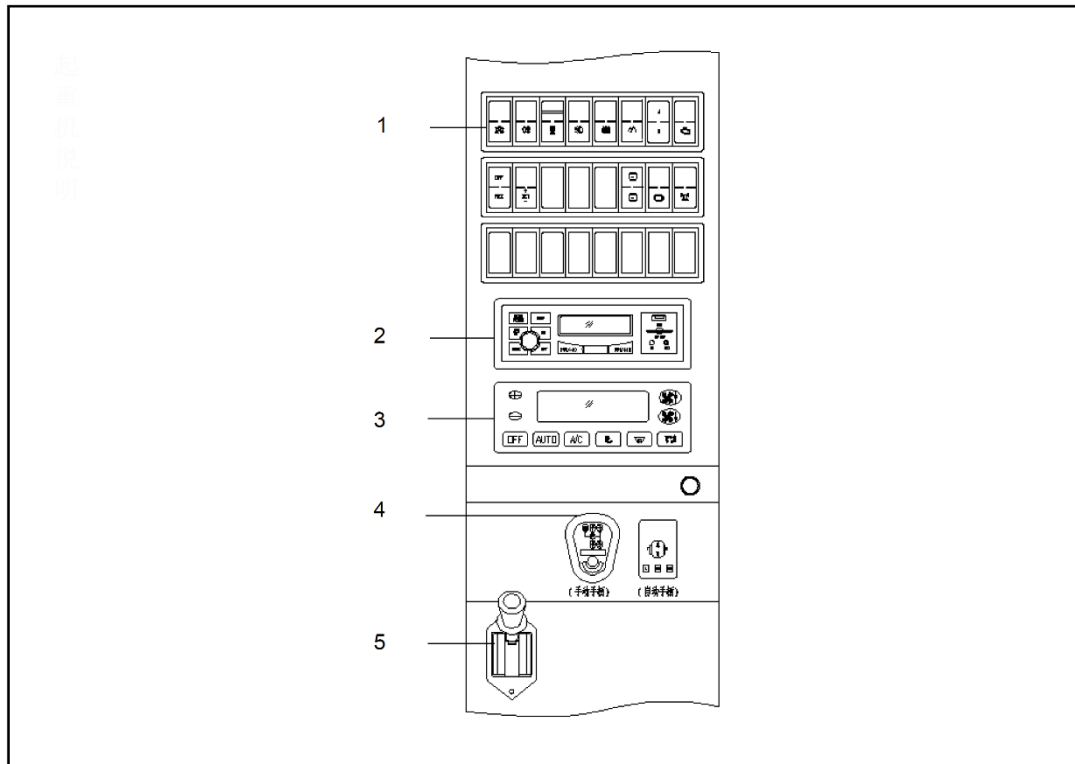

Figura 3-24 Teclado

Pos.	Descrição	Pos.	Descrição
1	Botão Parada do motor	8	Botão (entrada de decodificação opcional) Diagnóstico de falha do motor
2	Botão Farol de neblina traseiro	9	Interruptor de controle de cruzeiro (desligar/resetar)
3	Botão Travas dos diferenciais longitudinal e transversal	10	Interruptor de controle de cruzeiro (+/-)
4	Botão Interruptor de iluminação estabilizadora	11	Interruptor de carga de ar de 0,5Mpa/0,6Mpa
5	Botão Diagnóstico de falha do ABS	12	Botão de alívio de ar
6	Botão modo Terras Altas	13	Interruptor de sinalização giratória (opcional)
7	Interruptor de seleção do modo de controle, suspensão do eixo 5		

1 Botão de Parada do motor

Pressione e segure por 2 a 3 segundos:

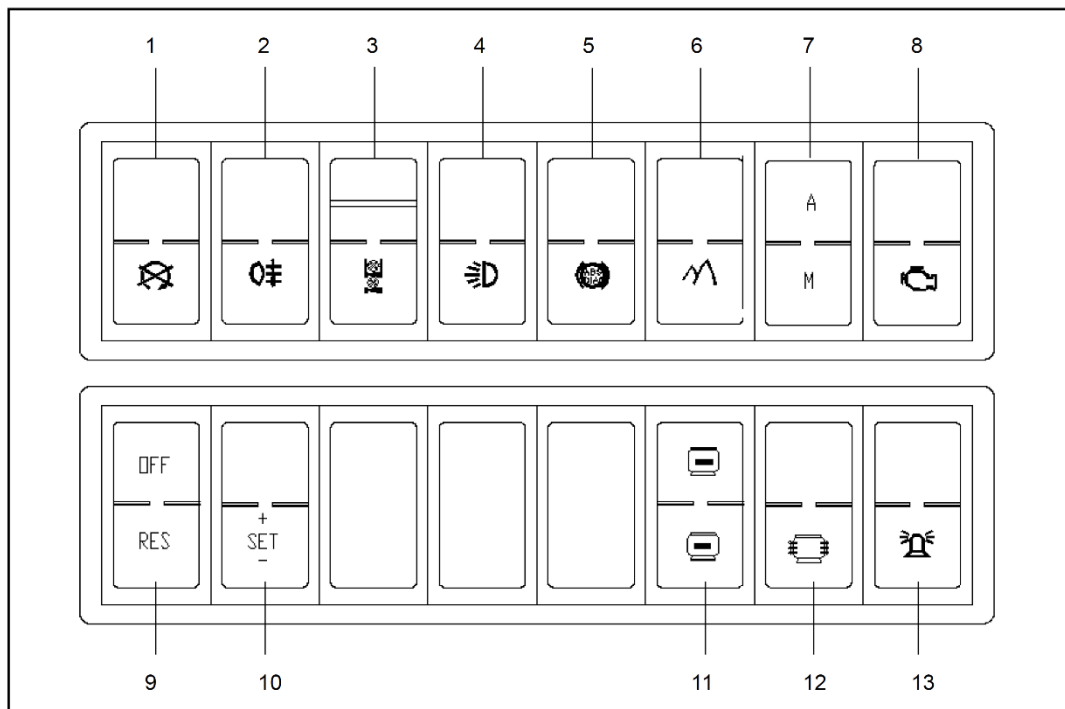
O motor para de funcionar.

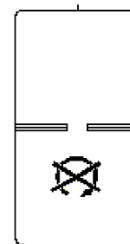
**2 Botão Luz de neblina traseira**

Pressionado:

A luz de neblina traseira está LIGADA.

Nota:

A luz de neblina traseira só pode ser ativada quando o farol alto ou o farol baixo estiver ativado.

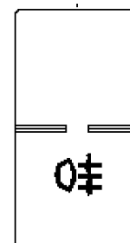
**3 Botão Travas dos diferenciais longitudinal e transversal**

Pressionado:

As travas dos diferenciais longitudinal e transversal são ativados.

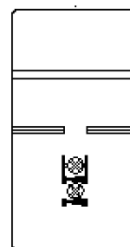

Você pode operar o botão somente quando o veículo estiver parado.

4 Botão Interruptor de iluminação estabilizadora Pressionado:

A iluminação estabilizadora está LIGADA durante o deslocamento. É usada principalmente para transição e iluminação do local de trabalho. Após a tomada de força, é inválido ligar este botão. No entanto, você pode ligar o interruptor da lâmpada de trabalho na caixa de controle estabilizadoras para acender a iluminação estabilizadora.

**5 Botão Diagnóstico de falha do ABS**

Quando o ABS emitir um alarme, pressione e segure este interruptor por 1-3 s e, em seguida, solte-o para ler o código flash do ABS para obter mais

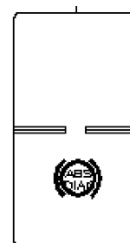

códigos de falha.

Para um Wabco ABS, pressione e segure este interruptor por 3-3,6 s para limpar o histórico de falhas.

6 Botão Modo Terras Altas Pressionado:

Para evitar o desligamento do motor após a tomada de força ser engatada para a superestrutura quando o veículo estiver trabalhando em terrenos montanhosos, a marcha lenta do motor aumentará automaticamente para o valor definido de 850 r/min depois que este botão for pressionado.

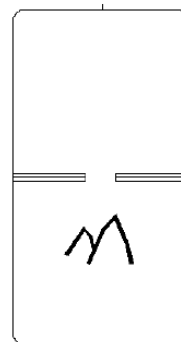

7 Interruptor de seleções do modo de controle, suspensão do eixo 5

R: automático; M: manual.

No modo automático, quando a tomada de força não estiver engatada e o freio de estacionamento for aplicado, a chave de 0,5/0,6 Mpa e a chave de pressão de alívio de ar são inválidas. A pressão do ar da suspensão do Eixo 5 é ajustada ao valor alvo de acordo com o contrapeso instalado. Quando a tomada de força estiver engatada ou durante o deslocamento do guindaste, o modo de controle automático é inválido.

No modo manual, quando o freio de estacionamento for aplicado e a tomada de força não estiver engatada, a chave de 0,5/0,6 Mpa e a chave de pressão de alívio de ar são válidas. A pressão do ar da suspensão do eixo 5 pode ser ajustada manualmente.

Nota: quando um pneu opcional 325/95R24

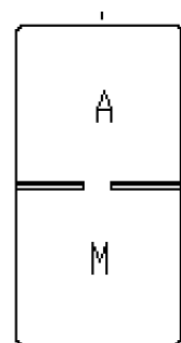

for instalado, o interruptor de carregamento de ar de 0,6 Mpa é inválido.

8 Botão Diagnóstico de falha do motor

É usado para inserir o interruptor de espera para decodificar urgentemente após o travamento automático do motor.

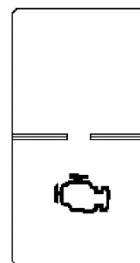

9 Interruptor de controle de cruzeiro (OFF/RESET) (Aplicável à transmissão automática)

O controle de cruzeiro pode ser desativado por qualquer uma das seguintes operações:

- Pisando no pedal da embreagem;
- Pisando no pedal de controle do motor;
- Pressionando o interruptor VVEB.

Pressione "RES" para retomar a função de controle de cruzeiro.

Pressione "OFF" para sair da função de controle de cruzeiro. Quando a função de cruzeiro não puder ser retomada pressionando a tecla RES, pressione "SET +" ou "SET -" para ativar a função.

O aumento da força de pressão no pedal de controle do motor pode desativar temporariamente a função de controle de cruzeiro, à medida que a entrada de torque aumenta. Depois que o pedal de controle do motor é liberado, a velocidade de cruzeiro original é retomada.

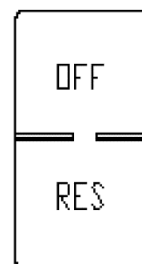

10 Interruptor de controle de cruzeiro (+/-)

(Aplicável à transmissão automática)

1) Entrada no controle de cruzeiro:

Quando a velocidade do veículo passar de 30 km/h e a rotação do motor estiver na faixa de 600-2800 rpm, pressione a tecla "SET +" ou "SET -" para entrar no controle de cruzeiro.

2) Ajuste da velocidade do controle de cruzeiro: Após entrar no controle de

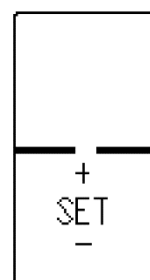

cruzeiro, pressione a tecla “SET +” ou “SET -” para aumentar ou diminuir a velocidade do controle de cruzeiro.

Cada pressão de “SET +” corresponde a um aumento de velocidade de 2km/h, e cada pressão de “SET -” corresponde a uma diminuição de velocidade de 2km/h. Cada vez que pressionar e segurar 机 de “SET +” “SET -” corresponde a um aumento ou diminuição de velocidade de 1,5 km/h/s.

11 Interruptor de carga de ar de 0,5 Mpa/0,6 Mpa

No modo manual, quando o freio de estacionamento for acionado e a tomada de força não estiver engatada, quando a pressão do ar é inferior a 0,5 Mpa ou 0,6 Mpa, pressione o interruptor de carga de ar de 0,5 Mpa ou 0,6 Mpa para carregar o ar na suspensão do Eixo 5 até uma meta de pressão de ar.

Nota: quando um pneu opcional 325/95R24 for instalado, o interruptor de carregamento de ar de 0,6 Mpa é inválido.

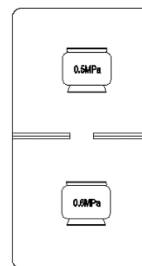

12 Botão de alívio de ar

No modo manual, quando a tomada de força não estiver engatada e o freio de estacionamento estiver acionado, pressione este interruptor para liberar o ar da suspensão do eixo 5.

Quando o freio de estacionamento estiver desengatado ou a tomada de força estiver engatada, este interruptor está inválido.

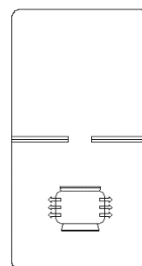

13 Botão Sinalização giratória

Está disponível para opções. **Pressionado:**
A iluminação giratória acende.

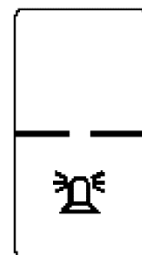

3.1.8.2 Reprodutor de mídia



Figura 3-25 Reprodutor de mídia

1 Botão

Fonte de alimentação / Modo pressionado:

Ligar a energia.

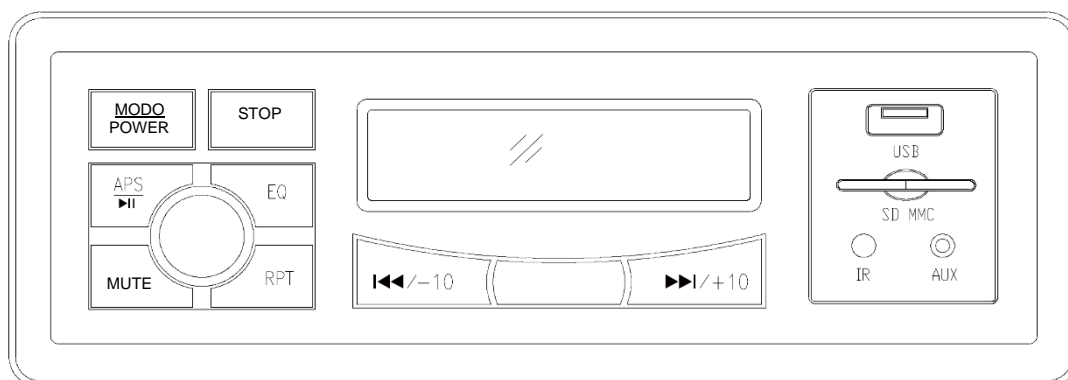
Pressionado novamente e liberado:

Mudar o modo. **Pressionado e mantido por 10 segundos:**

Desligar a energia.

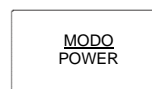
**2 Botão STOP Pressionado:**

As músicas reproduzidas por USB, SD-MMC ou dispositivo de áudio param.

**3 Botão**

Pausar/Busca automática de rádio Pressionado:

Pausar o MP3 player ou procurar automaticamente a estação de rádio e reservar a mesma.

**4 Botão EQ Pressionado:**

O EQ é ativado.

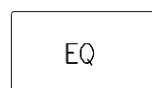

5 Botão MUTE pressionado:

O reprodutor de mídia está mudo.

Pressionado novamente:

O reprodutor de mídia retorna ao volume anterior.

**6 Botão RPT Pressionado:**

No modo de MP3, as músicas são repetidas.

**7 Botão****Reproduzir/Pesquisar estações de rádio ou músicas reservadas****Pressionado:**

No modo rádio, mantenha-o pressionado para pesquisar estações de rádio de alta frequência para baixa frequência.

No modo de MP3, mantenha-o pressionado para reproduzir as primeiras 10 músicas.

**8 Botão****Reproduzir/Pesquisar estações de rádio ou músicas reservadas****Pressionado:**

No modo rádio, mantenha-o pressionado para pesquisar estações de rádio de baixa frequência para alta frequência.

No modo de MP3, mantenha-o pressionado para reproduzir as primeiras 10 músicas.



Para informações detalhadas, favor consultar as *Instruções de Operação do Reprodutor de Mídia* em anexo.



Coloque o botão de partida em "ACC", quando for usar o reprodutor de mídia com o motor na posição OFF.

3.1.8.3 Alavanca de mudança de marcha

A alavanca de mudança de marcha está localizada no lado direito do banco do operador. Ela pode ser usada para selecionar e mudar a marcha.



Figura 3-26 Alavanca de mudança de marcha

F: tecla funcional

N: botão de marcha neutra (retornar à posição neutra) UP: empurre a alavanca para frente para aumentar uma marcha pesada: puxe a alavanca para trás para diminuir uma marcha

L: modo de baixa velocidade

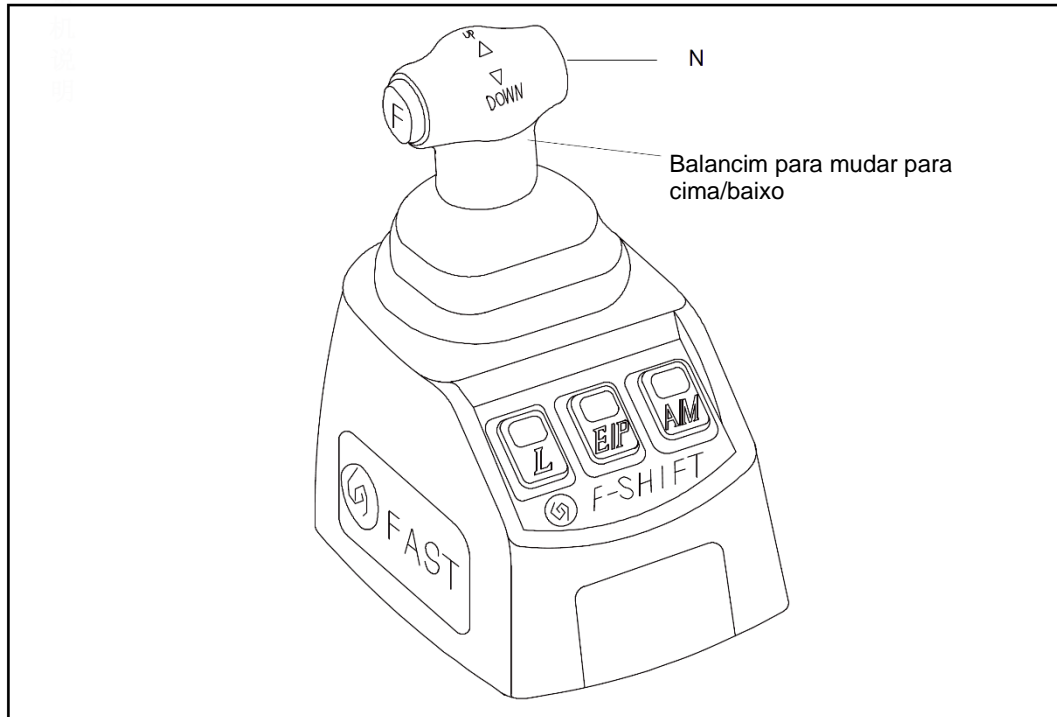
E/P: alternar entre o modo ECO e o modo power A/M: alternar entre o modo de mudança automática e manual

Uma FAST AMT (Transmissão Manual Automatizada) é usado para este guindaste. A alavanca de mudança de marchas é mostrada na Figura 3-26. Esta alavanca pode ser usada para alternar entre o modo de mudança de marcha automática e manual e mudar a posição da marcha etc.

Consulte a Seção 3.3.4 ou o manual do operador da transmissão para mais instruções operacionais.



A temperatura de trabalho da transmissão deve estar dentro da faixa de -40 °C - 120 °C,

caso contrário, seu lubrificante se decomporá, resultando em menor vida útil da transmissão.

3.1.8.4 Alavanca do freio de estacionamento

A alavanca do freio de estacionamento pode ser usada para frenagem de estacionamento e frenagem de emergência.



O veículo só pode arrancar depois de desengatado o freio de estacionamento e a luz indicadora do freio de estacionamento ter apagado!

3.1.8.5 Controle de pressão de ar para suspensão do Eixo 5

3.1.8.5.1 Requisitos de controle

Quando um pneu 325/95R24 opcional for instalado:

- a) Quando o guindaste estiver sendo conduzido com ou sem contrapeso, a pressão do ar da suspensão do Eixo 5 deve ser ajustada para $0,5 \pm 0,02$ Mpa (valor alvo). O ajuste da pressão do ar deve ser feito quando o freio de estacionamento estiver acionado e a tomada de força não estiver engatada.
- b) Quando a estrutura do chassi for instalada com duas ou mais placas de contrapeso, a velocidade de deslocamento do guindaste não deve exceder 50 km/h. Quando a pressão do ar for inferior a 0,40 Mpa ou superior a 0,7 Mpa por 5 min consecutivos, a velocidade do veículo é reduzida automaticamente para 10 km/h gradualmente.

Quando um pneu 415/80R22 opcional for instalado:

- a) Quando a estrutura do chassi não for instalada com contrapeso, a pressão do ar da suspensão do Eixo 5 deve ser ajustada para $0,5 \pm 0,02$ Mpa (valor alvo). Quando o guindaste estiver sendo conduzido com contrapeso, a pressão do ar deve ser ajustada para $0,6 \pm 0,02$ Mpa (valor alvo). O ajuste da pressão do ar deve ser feito quando o freio de estacionamento estiver acionado e a tomada de força não estiver engatada.
- b) Quando a estrutura do chassi for instalada com duas ou mais placas de contrapeso, a velocidade de deslocamento do guindaste não deve exceder 50 km/h.
- c) Quando o guindaste estiver viajando sem contrapeso, se a pressão do ar for inferior a 0,40 Mpa ou superior a 0,7 Mpa por 5 minutos consecutivos, a velocidade do veículo será reduzida para 10 km/h. Quando o guindaste estiver viajando com contrapeso, se a pressão do ar for inferior a 0,50 Mpa ou superior a 0,7 Mpa por 5 minutos consecutivos, a velocidade do veículo será reduzida para 10 km/h.

3.1.8.5.2 Modo de controle de pressão de ar

Quando um 325/95R24 opcional for instalado para o Eixo 5

Modo automático (interruptor de controle de pressão do ar está na posição A)

- a) Quando a segunda placa de contrapeso for detectada e a primeira não, o número de contrapeso é considerado como dois por padrão, e a pressão do ar da suspensão do Eixo 5 é ajustada automaticamente para $0,5 \pm 0,02$ Mpa. A velocidade de deslocamento é limitada a 50 km/h, e um alarme para instalação anormal do contrapeso é acionado.
- b) Durante o processo de deslocamento do veículo, quando a pressão do ar for inferior a 0,40 Mpa ou superior a 0,7 Mpa por 5 min consecutivos, um alarme de anormalidade da pressão do ar será acionado e a velocidade de deslocamento é reduzida para 10 km/h gradualmente em 5 min.
- c) No caso de um sensor de pressão de ar com defeito, um alarme será acionado e este modo automático será encerrado.
- d) Quando o freio de estacionamento for acionado e a tomada de força não for engatada, se a pressão do ar da suspensão do Eixo 5 não atingir o valor alvo, um alarme de sobrepresão ou subpressão será acionado. Após 3 s, o alívio de ar ou carga será iniciado. O guindaste só pode ser acionado quando o ícone de alarme desaparecer no painel de instrumentos.

Modo manual (interruptor de controle de pressão do ar está na posição M)

- a) No modo manual, o ajuste de pressão não pode ser feito por meio de alívio de ar automático ou carga. O carregamento de ar de 0,5 Mpa ou o interruptor de alívio de ar precisa ser operado manualmente para iniciar o alívio ou carregamento de ar.

Nota: O interruptor de carregamento de ar de 0,6 Mpa é inválido nesse caso. A operação acima deve ser feita quando o freio de estacionamento estiver acionado e a TDF não estiver engatada. Não há limite de velocidade.

- b) Quando o guindaste estiver sendo conduzido e a pressão do ar for inferior a 0,40 Mpa ou superior a 0,7 Mpa por 5 min consecutivos, um alarme de anormalidade da pressão do ar será acionado e a velocidade de deslocamento será reduzida para 10 km/h gradualmente em 5 min. Somente após o freio de estacionamento ser acionado para ajustar a pressão do ar à sua faixa normal, a limitação de velocidade e o alarme correspondentes desaparecerão, caso contrário, eles reaparecerão após 5 min.

Quando um 325/95R24 opcional for instalado para o Eixo 5:

Modo automático (interruptor de controle de pressão do ar está na posição A)

- a) Quando a segunda placa de contrapeso for detectada e a primeira não, o número de contrapeso é considerado como dois por padrão, e a pressão do ar da suspensão do Eixo 5 é ajustada automaticamente para $0,6 \pm 0,02$ Mpa. A velocidade de deslocamento é limitada a 50 km/h, e um alarme para instalação anormal do contrapeso é acionado.
- b) Quando o guindaste estiver sendo conduzido sem contrapeso, se a pressão do ar for inferior a 0,40 Mpa ou superior a 0,7 Mpa por 5 min consecutivos, um alarme de

anormalidade da pressão do ar será acionado e a velocidade de deslocamento é reduzida para 10 km/h gradualmente em 5 min. Quando o guindaste estiver sendo conduzido com contrapeso, se a pressão do ar for inferior a 0,50Mpa ou superior a 0,7Mpa por 5 min consecutivos, um alarme de anormalidade da pressão do ar será acionado e a velocidade de deslocamento é reduzida para 10 km/h gradualmente em 5 min.

- c) No caso de um sensor de pressão de ar com defeito, um alarme será acionado e este modo automático será encerrado.
- d) Quando o freio de estacionamento for acionado e a tomada de força não for engatada, se a pressão do ar da suspensão do Eixo 5 não atingir o valor alvo, um alarme de sobrepressão ou subpressão será acionado. Após 3 s, o alívio de ar ou carga será iniciado. O guindaste só pode ser acionado quando o ícone de alarme desaparecer no painel de instrumentos.

Modo manual (interruptor de controle de pressão do ar está na posição M)

- a) No modo manual, o ajuste de pressão não pode ser feito por meio de alívio de ar automático ou carga. O interruptor de carga de ar de 0,5Mpa/0,6Mpa ou de alívio de ar precisa ser operado manualmente para iniciar o alívio ou carregamento de ar.

Nota: A operação acima deve ser feita quando o freio de estacionamento estiver acionado e a TDF não estiver engatada. Não há limite de velocidade.

- b) Quando o guindaste estiver sendo conduzido e a pressão do ar for inferior a 0,45Mpa ou superior a 0,7Mpa por 5 min consecutivos, um alarme de anormalidade da pressão do ar será acionado e a velocidade de deslocamento será reduzida para 10 km/h gradualmente em 5 min. Somente após o freio de estacionamento ser acionado para ajustar a pressão do ar à sua faixa normal, a limitação de velocidade e o alarme correspondentes desaparecerão, caso contrário, eles reaparecerão após 5 min.

AVISO

Quando o guindaste estiver sendo conduzido sem contrapeso, a pressão do ar da suspensão do Eixo 5 deve ser ajustada para $0,5 \pm 0,02$ Mpa; Quando o guindaste estiver sendo conduzido com contrapeso, a pressão do ar deve ser ajustada de acordo com os pneus instalados para o Eixo 5, caso contrário, o eixo e a suspensão ficarão sobrecarregados, resultando em avaria grave.

Quando o guindaste estiver sendo conduzido, o modo automático deve ser ativado. Se o modo manual for ativado, o controle parcial se perderá, resultando em sobrecarga do eixo e da suspensão e avaria grave.

3.1.9 Iluminação do guindaste

3.1.9.1 Sinais de combinação frontal

Tome as luzes à esquerda como exemplo. As luzes do lado direito são as mesmas que as da esquerda.

Para detalhes, consulte a Figura 3-27.



Figura 3-27 Setas de combinação dianteiras

3.1.9.2 Seta lateral

Tome a seta à esquerda como exemplo. A seta do lado direito é a mesma que a da esquerda. Para detalhes, consulte a Figura 3-28.

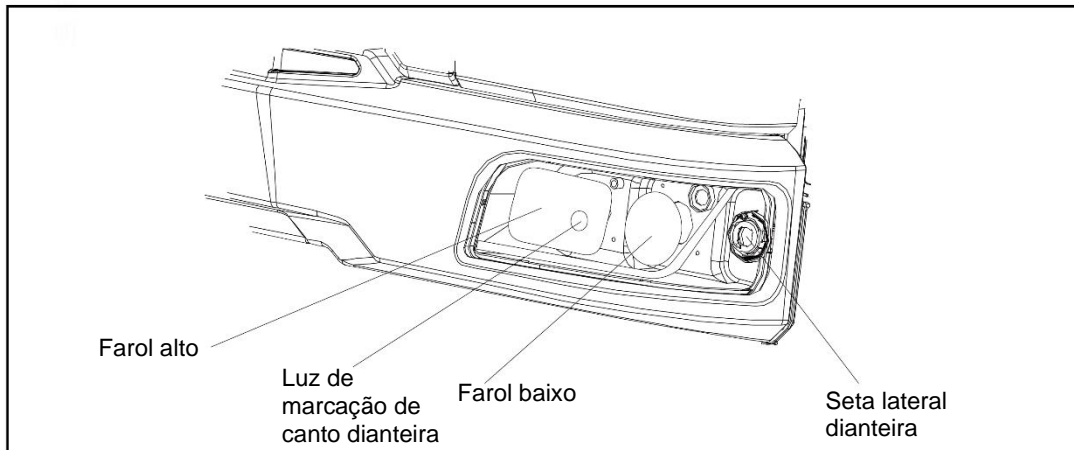

Figura 3-28 Seta lateral

3.1.9.3 Iluminação interna

A iluminação interior está localizada no teto da cabine do operador, incluindo a lâmpada pequena e seu botão e a lâmpada da porta e seu botão.

Luz pequena e seu botão:

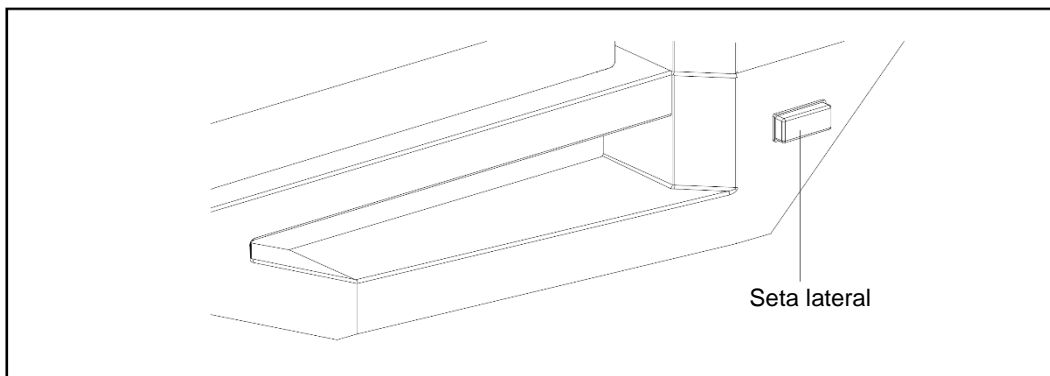
A direção da luz lâmpada pode ser ajustada pressionando sua borda. O botão da luz pequena é um botão de 2 mãos.

Luz da porta e seu botão:

O botão da luz da porta é um botão de 3 mãos:

Posição central: desligada

Posições esquerda e direita: ligada A luz da porta acende automaticamente se alguma porta estiver aberta. Se as portas estiverem bem fechadas, a luz da porta se apagará. Além disso, a luz da porta também pode ser controlada manualmente.

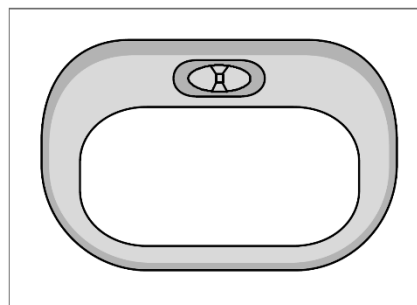

3.1.10 Porta, cabine do operador

a) Abra a porta pelo lado de fora Segure a maçaneta e puxe-a para fora.

b) Feche a porta

A porta será travada automaticamente quando a porta for fechada.

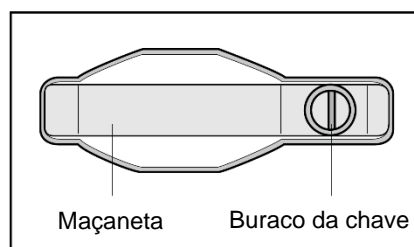

Não conduza o veículo se as portas não estiverem devidamente fechadas e trancadas!

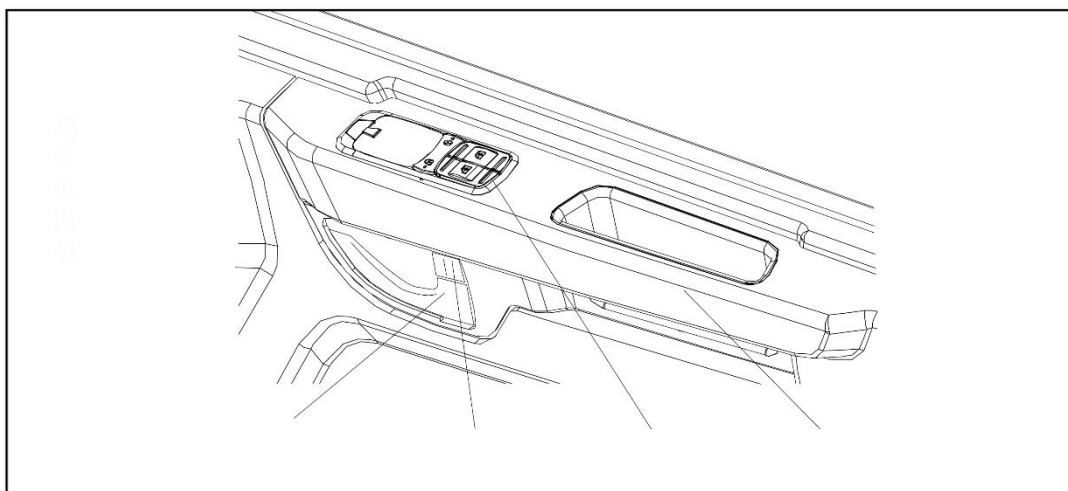
**Figura 3-29 Porta da cabine do operador**

- c) Abrir a porta por dentro
Puxe o interruptor da porta interna para cima e segure a maçaneta para empurrar a porta para fora.
- d) Tranque a porta por dentro
O botão de travamento está na borda inferior da janela da porta. Pressione o botão de travamento para travar a porta por dentro. Puxe o botão de travamento para cima antes de abrir a porta.



Interruptor da porta interno

Interruptor de travamento

Interruptor de vidro elétrico Maçaneta da porta

Se a porta não estiver bem fechada, o botão de travamento não pode ser pressionado.

- e) Travar a porta por fora
Insira a chave do veículo no orifício da chave. Gire no sentido horário para travar a porta, gire no sentido anti-horário para destravar a porta.

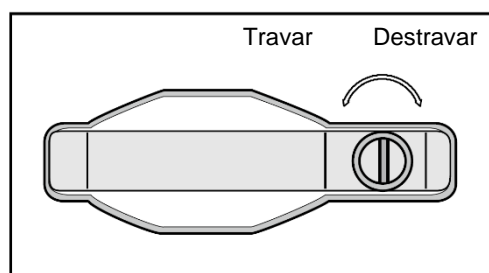

3.1.11 Assentos na cabine do operador

3.1.11.1 Ajuste do assento

Este guindaste está equipado com um assento

com suspensão, que pode ser ajustado para se adequar a qualquer

altura ou tamanho do operador antes do deslocamento.

Ao ajustar a rigidez do assento, por favor, defina o ponteiro vermelho dentro do intervalo entre 40 kg a 130 kg.

1. Interruptor, ajustar a configuração do encosto

2. Interruptor, ajustar o ângulo do assento (parte traseira)

3. Interruptor, ajustar o ângulo da almofada do assento (seção dianteira)

4. Botão giratório, ajustar a rigidez

5. Interruptor, ajustar a configuração horizontal

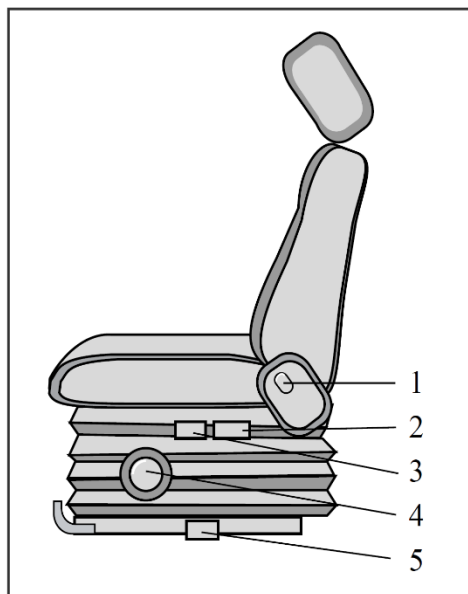

3.1.11.2 Posições dianteiras e traseiras e ângulo do encosto

O ângulo do encosto do banco do operador é de 97°, enquanto o do banco do passageiro é de 105°, conforme mostrado na Figura 3-30.



Figura 3-30 Posições dianteiras e traseiras e ângulo do encosto

3.1.11.3 Colocando o cinto de segurança

Aperte e ajuste o cinto de segurança de três pontos na posição adequada antes de deslocar o guindaste.

Insira a lingueta no prendedor do cinto para prender o cinto.

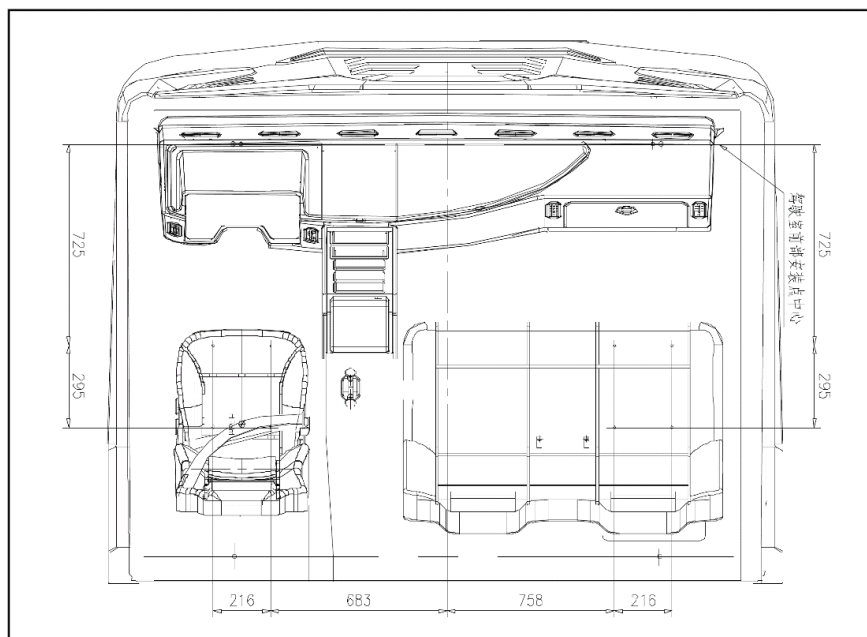
Pressione o botão para soltar o cinto.



Risco de ferimentos fatais se o cinto de segurança não for usado!

Todos os ocupantes devem usar cinto de segurança antes de deslocar o guindaste e durante o deslocamento.

3.1.11.4 Local de repouso

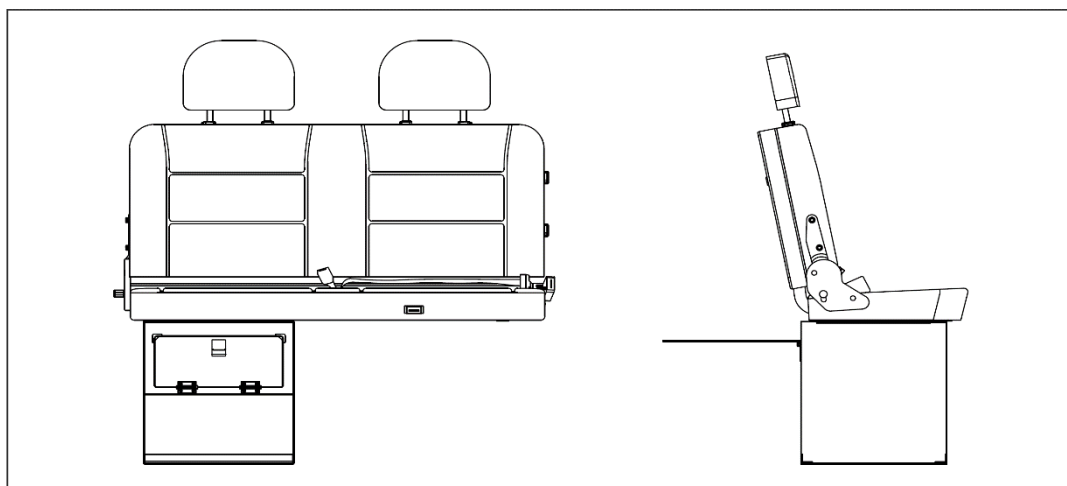
**Figura 3-31 Local de repouso**

O banco do passageiro está conectado ao banco do operador e pode ser usado como local de descanso. Maçaneta da trava da porta: mova a maçaneta da porta da caixa de ferramentas para fora para abrir a placa da caixa de ferramentas. Opere no sentido inverso para fechar.

3.1.12 Anexos

a) Para-sol

O para-sol está localizado acima do para-brisa dianteiro dentro da cabine do operador.

Puxe o para-sol para baixo para bloquear a luz do sol.

Empurre o para-sol para cima para guardá-lo.

b) Caixa de ferramentas 2

A caixa de ferramentas 2 se encontra no console de instrumentos da cabine do operador, na qual existem duas caixas de ferramentas de tamanhos diferentes.

Pressione o interruptor para abrir a caixa de ferramentas 2 e empurre a tampa para

baixo para fechá-la.

c) Acendedor de cigarro

Empurre o acendedor durante 3 a 5 seg. Puxe-o para fora para usar. Após usar, coloque-o em sua posição inicial.



Coloque o botão de partida em "ACC", quando for usar o acendedor de cigarro com o motor na posição OFF.

3.2 Antes de dar partida no veículo

3.2.1 Pré-requisitos

- a) Se o guindaste for usado pela primeira vez, certifique-se de que ele esteja em boas condições de funcionamento (sem danos ou anormalidades).
- b) Use sempre o óleo diesel leve e o óleo do motor corretos. Faça sua seleção na temperatura ambiente mais baixa onde você deve fazer o trabalho. Para detalhes, favor consultar o *Manual de Operação e Manutenção do Motor Diesel Série WP 10 *** e o *Manual de Operação e Manutenção do Motor Diesel Série WP 12 ***.

3.2.2 Verificações gerais antes de deslocar o guindaste

- a) Examinando o nível do óleo
 - 1) Examine o nível de óleo no motor do veículo.
 - 2) Examine o nível de óleo na transmissão e nos eixos.
 - 3) Examine o nível de óleo no tanque de óleo hidráulico do chassi.
- b) Examinando a reserva de combustível
Examine a reserva de combustível no medidor de combustível na cabine do operador.



(1) Não opere o guindaste até o tanque de combustível secar!

Se o tanque de combustível estiver seco, sempre remova o ar de todo o sistema de combustível.

(2) O intervalo razoável de troca da mangueira de combustível é de 24 meses ou 20.000 km.

- c) Examinando o nível do refrigerante
Examine o nível de refrigerante no medidor de nível de líquido no tanque de expansão. Encha o reservatório de refrigerante auxiliar até perto da marca "MAX".



Risco de lesão por escaldadura da pele.

O motor deve estar frio durante a verificação do nível da água de resfriamento.

- d) Examinando o nível de AdBlue
Examine o nível de AdBlue na interface principal no painel de instrumentos na cabine do operador.



Quando o sistema SCR for executado, se ocorrerem as seguintes situações:

- Não adiciona o AdBlue.
- O AdBlue não é qualificado.

- O AdBlue é inferior a 14%.

O motor emitirá um alarme. E depois que o motor estiver funcionando por 60 min ou quando o motor for ligado na próxima vez, o torque de saída do motor será limitado a 60% do valor máximo até que o AdBlue adequado seja adicionado.



Se o sistema SCR não puder retornar ao trabalho normal, as luzes de aviso "falha SCR" e "Código de erro do motor exibido" permanecerão acesas após o veículo ser eletrificado e o motor dar partida.



Se as emissões do veículo não atenderem ao padrão de emissão, a administração local de proteção ambiental e o departamento de transporte punirão as partes correspondentes.

- e) Examinando os pneus
 - 1) Examine as condições de trabalho dos pneus.
 - 2) Examine a pressão do ar e encha os pneus com os valores especificados (1 MPa para pneus 385/95R25 e 325/95R24; 0,93 MPa para pneus 415/80R22).



Ao encher os pneus, não exceda a pressão de ar máxima.

- f) Examinando as conexões de montagem
 - 1) Certifique-se de que as peças a seguir estejam apertadas:
 - Parafusos nos sistemas de direção e acionamento
 - Parafusos da roda.
 - 2) Certifique-se de que as peças dos sistemas de direção e freio sejam flexíveis, seguras e confiáveis. Certifique-se de que as peças a seguir estejam apertadas:
 - Conexões da barra de arrasto da direção
 - Parafusos de retenção dos volantes
 - Câmaras de freio dos eixos
 - Tubos.
- g) Examinando se os itens a seguir estão danificados:
 - Travas das portas
 - Portas
 - Janelas
 - Mecanismos operacionais.
- h) Examinando a posição correta dos espelhos externos.
- i) Examinando o sistema elétrico

- 1) Examine os terminais da bateria para ver se estão muito corroídos e certifique-se de que os cabos de alimentação estejam apertados.
- 2) Examine o nível do eletrólito da bateria.
- 3) Gire o botão de partida para a posição "ON" e examine as funções dos itens a seguir:
 - Instrumentos
 - Interruptores e botões
 - Iluminação
 - Luzes de controle e luzes de aviso
 - Limpadores.
- j) Examinando os tubos
 - 1) Examine as conexões dos tubos de óleo, tubos de ar e tubos de água quanto a vazamentos.
 - 2) Examine o reservatório de ar quanto à condensação (drene a água conforme necessário).



Figura 3-32 Reservatório de ar

! CUIDADO

- (1) **Incline ou retire a alavanca da válvula de drenagem para drenar a água.**
- (2) **Não ligue o veículo até que a válvula de drenagem esteja fechada após a drenagem da água.**
- (3) **Examine o indicador acionado por vácuo do filtro de ar. Se a luz estiver na área vermelha, limpe ou substitua o elemento de filtro.**
- (4) **A pressão nominal de trabalho para o reservatório de ar é de 0,9 Mpa.**

! CUIDADO

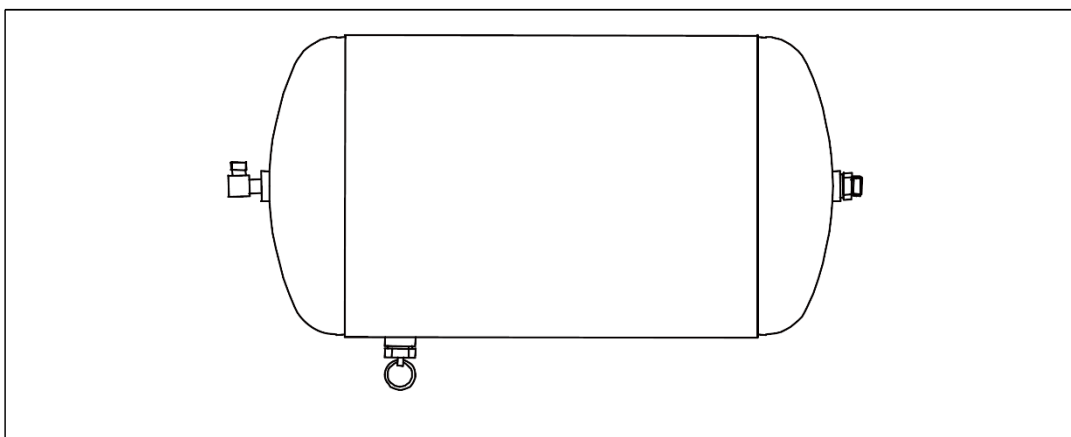
Remova toda a contaminação (pó e areia) do coletor de pó na parte inferior do filtro de ar.

- k) Antes que o guindaste possa ser conduzido em vias públicas, certifique-se de que os seguintes pré-requisitos sejam atendidos:
- Todas as peças soltas são fixadas no guindaste.
 - A cabine do operador está no sentido da condução e fixada mecanicamente.
 - A lança telescópica está totalmente recolhida e colocada no suporte da lança.
- l) Examinando a iluminação
- Gire o botão de partida para a posição “ACC” e examine a iluminação antes de mover o guindaste. Consulte a Figura 3-33.



Figura 3-33 Iluminação do veículo

Pos.	Descrição	Pos.	Descrição
1	Luzes de trabalho na cabeça da lança	8	Setas de combinação dianteiras esquerdas
2	Setas laterais	9	Luz de marcação do canto traseiro esquerdo, superior
3	Luzes de marcação lateral e refletores	10	Luz de marcação do canto traseiro direito, superior
4	Iluminação de feixe deslizante	11	Setas de combinação traseiras esquerdas
5	Luzes de marcação do canto dianteiro direito, teto	12	Setas de combinação traseiras direitas
6	Luzes de marcação do canto dianteiro esquerdo, teto	13	Luz da placa de licença
7	Setas de combinação dianteiras direitas		

- 1) Setas de combinação traseiras esquerdas (na parte traseira esquerda da estrutura do chassi) Consulte a Figura 3-34.

As setas de combinação traseiras esquerdas são combinadas em uma placa retangular.

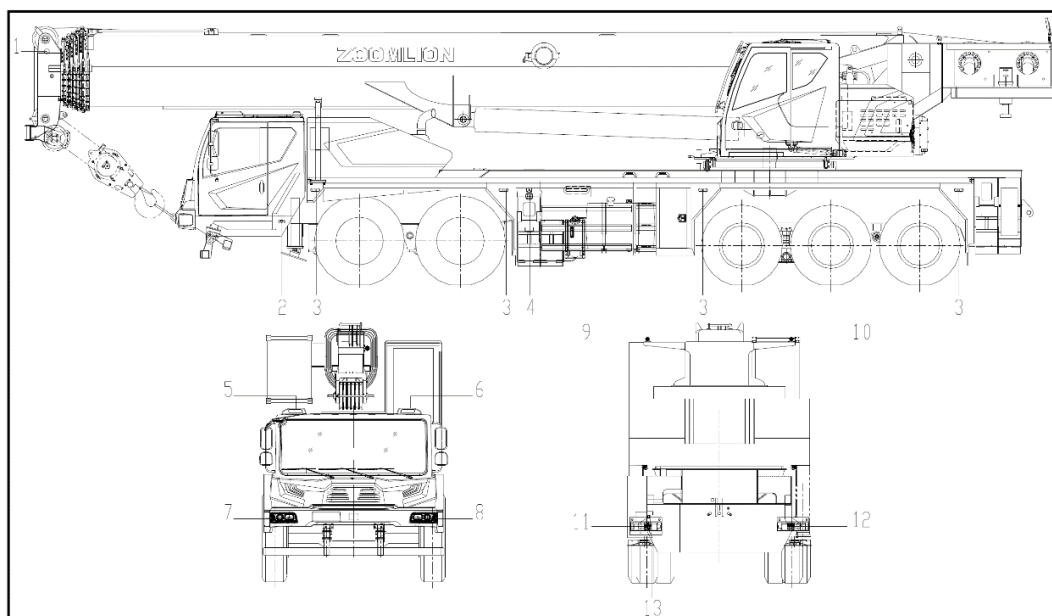

Figura 3-34 Setas de combinação traseiras esquerdas

Pos.	Descrição	Pos.	Descrição
1	Luz marcadora de canto (vermelha)	5	Lâmpada de largura traseira (vermelha)
2	Seta (âmbar)	6	Luz de neblina traseira (vermelha)
3	Luzes de freio (vermelhas)	7	Luz de ré (branca)
4	Refletor		

- 2) Setas de combinação traseiras direitas (na parte traseira direita da estrutura do chassi)
As setas de combinação traseiras direitas estão na parte traseira direita da estrutura do chassi.

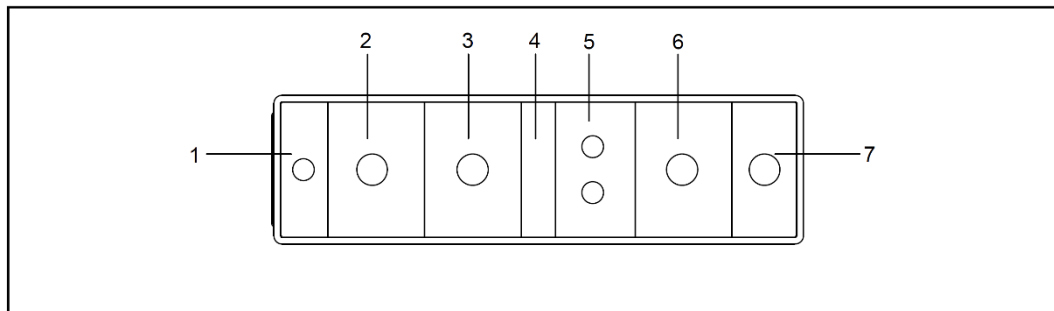

Figura 3-35 Setas de combinação traseiras direitas

Pos.	Descrição	Pos.	Descrição
1	Luz de ré (branca)	5	Luzes de freio (vermelhas)
2	Luz de neblina traseira (vermelha)	6	Seta (âmbar)
3	Lâmpada de largura traseira (vermelha)	7	Luz marcadora de canto (vermelha)
4	Refletor		

Examine as seguintes iluminações e dispositivos de aviso antes de deslocar o guindaste.

- 1 Iluminação interna
 - Está instalada no teto da cabine do operador para fornecer iluminação interna.
- 2 Iluminação do feixe deslizante
 - São instalados próximos às caixas estabilizadoras dianteiras para fornecer iluminação para as vigas
 - de deslizamento. É conveniente para o operador observar as condições de trabalho das vigas deslizantes à noite.
- 3 Campainha
 - A luz de ré acenderá e a campainha emitirá um alarme lento quando a marcha à ré for aplicada.
 - A luz de aviso “Baixa pressão do freio” acenderá e a campainha emitirá um alarme lento quando a pressão do sistema de freio a ar estiver baixa.
 - A luz de aviso “Alta temperatura do refrigerante do motor” acenderá e a campainha emitirá um alarme lento quando a temperatura do refrigerante do motor estiver alta.

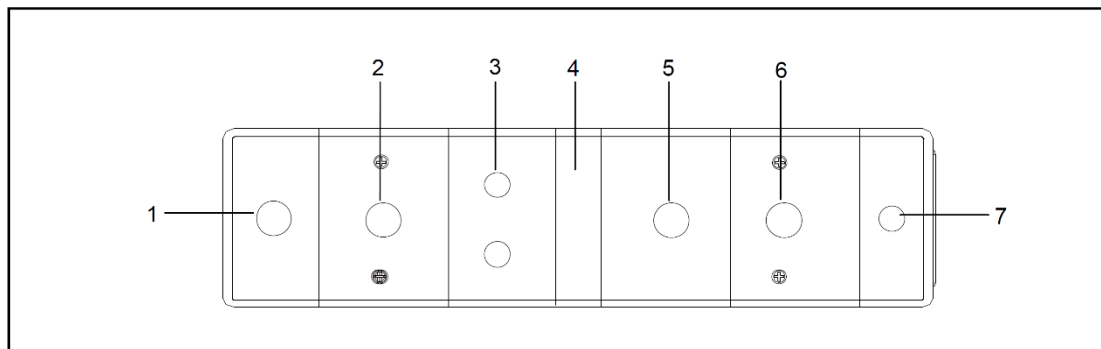

Perigo de acidente se a iluminação estiver defeituosa!

Providencie para que as luzes defeituosas sejam reparadas por um especialista antes de deslocar o guindaste!

- m) Cabine do operador
 - 1) Regulagem do assento do operador

O assento do operador pode ser ajustado para se adequar à altura ou tamanho de qualquer operador. Ajuste o assento do operador antes de deslocar o guindaste.

 - Regulagem do encosto
 - Ângulo da almofada do assento (seção traseira)
 - Ângulo da almofada do assento (seção dianteira)
 - Regulagem horizontal
 - Amortecedor.
 - 2) Regulagem do espelho

Limpe os retrovisores externos antes de deslocar o guindaste e regule-os de acordo com o campo de visão do operador. Regule os retrovisores externos manualmente.
 - 3) Regulagem o volante

O volante é ajustado mecanicamente.

Opere a alavanca de ajuste do volante (consulte a Seção 3.1.2).

Resultado:

- O ângulo e a altura do volante são regulados de acordo com o operador.

**PERIGO**

Não regule o volante, o assento do operador e os retrovisores externos enquanto estiver dirigindo.

**CUIDADO**

Desligue a válvula de gaveta de desligamento no tubo de água quente do aquecedor na parte inferior da cabine do operador quando usar o ar condicionado no verão e ligue a válvula no inverno.

3) Examinando os controles principais

Certifique-se de que a chave geral da bateria esteja ligada ao fazer as seguintes verificações. Examine os seguintes componentes:

- Farol alto
- Luz de neblina traseira
- Buzina
- Sinalizações giratórias
- Limpador de para-brisa/sistema do lavador/recipiente de fluido de lavagem de para-brisa

**PERIGO**

Perigo de morte devido a comandos principais defeituosos! Providencie para que um especialista repare as funções defeituosas antes de deslocar o guindaste.

n) Fusível

- 1) Abra a tampa do console central e retire-a.
- 2) Abra a tampa da caixa de fusíveis.
- 3) Examine o fusível e substitua o defeituoso.

**AVISO**

Use o fusível do mesmo tamanho e especificação. Caso contrário, o sistema elétrico será danificado.

3.2.3 Verificações gerais na partida do veículo

Examine os controles e instrumentos.

- a) Examine o medidor de pressão do óleo do motor.
 - 1) Velocidade de marcha lenta: A pressão do óleo do motor deve ser superior a 0,1 MPa.
 - 2) RPM do motor (1200 r/min.): A pressão do óleo do motor não deve ser inferior a 0,35 MPa – 0,55 MPa.
- b) Examine os barômetros.

Se a pressão do freio for inferior a 0,55 MPa, a luz de aviso “Baixa pressão do

freio” acenderá. Risco de perigo se você deslocar o guindaste neste momento!

- c) Examine o termômetro.
 - 1) O ponteiro deve apontar para o intervalo (acima de 60 °C). Não dirija o veículo em alta velocidade até que a temperatura do líquido de arrefecimento atinja 70 °C.
 - 2) Todas as luzes de aviso devem apagar (incluindo as luzes de controle “baixa pressão”, “freio de estacionamento fechado”, “freio motor”, “trava do diferencial longitudinal” e “trava do diferencial transversal” etc.
- d) Desative a alavanca de controle da tomada de força (não aplicável a um guindaste com AMT).
- e) A pressão do circuito de ar de controle da embreagem deve ser maior que a pressão de partida.
- f) Se a trava do diferencial longitudinal e a trava do diferencial transversal estiverem instaladas, desengate-as antes da condução normal.
- g) Certifique-se de que o freio de estacionamento esteja liberado.
- h) Dê partida no veículo em baixa velocidade e evite que a embreagem engate quando a rotação do motor exceder 1600 rpm.

3.3 Condução do guindaste

3.3.1 Partida e parada do motor

3.3.1.1 Partida do motor

- a) Examine os itens a seguir:
 - 1) O nível correto do óleo do motor e certifique-se de que esteja limpo
 - 2) Nível correto do refrigerante
 - 3) Nível correto do tanque de combustível
 - 4) Nível correto do tanque de AdBlue
- b) Antes de dar partida no motor, certifique-se de que os seguintes pré-requisitos sejam atendidos:
 - 1) Coloque a alavanca de câmbio em ponto morto.
 - 2) Acione o freio de estacionamento.
 - 3) Gire o botão de partida para a posição “ON”.
 - 4) Desengate a tomada de força (Neste momento, a luz de controle “PTO engatada” não acende).
 - 5) No inverno, o motor será pré-aquecido automaticamente (A luz de controle “Sistema de pré-aquecimento do motor diesel” acende ao mesmo tempo).
 - 6) Depois que a luz de controle “Sistema de pré-aquecimento do motor diesel” se apagar, pise no pedal de controle do motor suavemente e gire o botão de partida para a posição S para dar partida no motor.



- (1) **Gire o interruptor de partida da ignição para a posição S dentro de 30 segundos após a luz de controle “Sistema de pré-aquecimento do motor a diesel” ter se apagado.**
- (2) **Se você não conseguir dar partida no motor em no máximo 7 segundos, aguarde 30 segundos. Em seguida, tente ligar o motor novamente para evitar danos ao motor.**
Se o motor não puder ser ligado por três tentativas consecutivas, conserte-o imediatamente.



Para um guindaste instalado com transmissão manual, pise no pedal da embreagem ao dar partida no motor para evitar a partida inadvertida do veículo.

- c) Pré-aqueça o motor e examine as funções dos instrumentos:
Solte o pedal de controle do motor lentamente e opere o motor em marcha lenta por

vários minutos para aquecê-lo. Neste momento, examine os instrumentos e as luzes de controle/aviso para verificar as funções.

 **CUIDADO**

- (1) Para fazer o óleo do motor fluir por todo o motor e aumentar a temperatura da água para queimar o combustível normalmente, é necessário aquecer o motor antes de dar partida.
- (2) Não funcione o motor em alta velocidade sem carga durante o aquecimento. Caso contrário, o motor será danificado e sua vida útil será reduzida.
- (3) Não deixe o motor funcionar em marcha lenta por muito tempo, o que pode diminuir o desempenho do motor.
- (4) Não ligue o motor em alta velocidade com carga pesada quando a temperatura do refrigerante estiver abaixo de 60 °C.
- (5) A pressão do óleo do motor não deve ser inferior a 0,1 MPa quando o motor estiver funcionando em marcha lenta. Com o motor aquecendo, a pressão do óleo se estabilizará gradualmente.

 **AVISO**

Não funcione o motor em um local onde exista gás combustível.

O gás pode ser puxado para dentro do motor através do sistema de admissão de ar para o motor acelerar mesmo em excesso de velocidade, o que pode causar incêndio, explosão e enormes prejuízos.

3.3.1.2 Desligando o motor

- a) Pise levemente no pedal do freio de serviço para desacelerar o veículo, ao mesmo tempo, reduza a transmissão para a marcha 1.
- b) Quando o motor desacelerar para a velocidade baixa, pise no pedal da embreagem e o pedal do freio de serviço ao mesmo tempo para parar o veículo no local especificado (não aplicável a um guindaste instalado com transmissão manual).

 **CUIDADO**

Exceto em caso de emergência, não pise no pedal do freio de serviço bruscamente!

- c) Puxe a alavanca do freio de estacionamento para trás para a posição de travamento para estacionar o veículo e, em seguida, coloque a transmissão para a posição neutra.
- d) Deixe o motor funcionar em marcha lenta por vários minutos após o veículo parar para resfriar o motor gradualmente.
- e) Pressione o botão “Parada do Motor” por 2 a 3 segundos. para parar o motor do chassi.
- f) Gire o botão de partida para a posição “LOCK” e puxe-o para fora após o motor ter parado cerca de 30 segundos.

- g) Não mantenha o botão de partida na posição "ON" ou "ACC" depois de estacionar o guindaste. A bateria descarrega nestas condições.
- h) Se estacionar o guindaste num declive, você deve colocar calços na frente e atrás das rodas para evitar acidentes.
- i) Para evitar um acidente ao estacionar o guindaste no escuro, você deve acender as luzes de perigo.

3.3.2 Conduzindo

- a) Alterando a velocidade de marcha lenta



Pise no pedal da embreagem antes de mudar de "N" para "D". A rotação do motor diminuirá um pouco depois que você selecionar a marcha necessária (não aplicável a um guindaste instalado com transmissão manual).



Faça o motor funcionar em marcha lenta antes de mudar de "N" para "D" ou "R" quando o guindaste estiver parado.

- b) Regulagem da suspensão do eixo
Destrave a suspensão do eixo e nivele o veículo.



- (1) **Não solte o freio de estacionamento até que a luz de aviso "Baixa pressão do freio" se apague (a pressão do ar atinge 5,5 bar). Puxe a alavanca manual novamente e encha de ar comprimido até que a luz de aviso se apague!**
- (2) **Quando o freio de estacionamento for liberado, o guindaste pode começar a se mover imediatamente.**

- c) Examinando o sistema de freio

- 1) Freio de serviço

Pise no pedal de controle do motor para aumentar a rotação do motor. O veículo começa a se mover. Pise no pedal do freio de serviço e examine o freio de serviço.

- 2) Retardador

O retardador é o freio motor.



O máximo cuidado deve ser tomado ao operar o freio motor!

 CUIDADO

- (1) **Acione o freio motor somente com o motor funcionando.**
- (2) **O uso sensato do retardador com métodos de condução de antecipação reduz o desgaste do freio de serviço e, assim, reduz o custo operacional.**
- (3) **Em declives extensos, selecione um estágio de comutação que deixe outros estágios de comutação disponíveis para quaisquer outros procedimentos de frenagem de ajuste que possam ser necessários. Use corretamente o freio motor, tanto quanto possível, para relaxar o freio de serviço.**

 AVISO

Caso as rodas travem ao acionar o freio motor, selecione um estágio de comutação mais baixo!

3.3.3 Instrumentos de controle importantes durante a condução

- a) Examinando a pressão do óleo do motor
Exibição da pressão do óleo do motor no gráfico de barras na unidade de exibição de 1 bar – 5,5 bar.

 CUIDADO

Em caso de baixa pressão do óleo (a pressão do óleo do motor está abaixo de 0,06 MPa), não há lubrificação do motor. Isso resulta em danos ao motor. Pare imediatamente o guindaste e desligue o motor. Examine o sistema de lubrificação.

- b) Examinando o suprimento de ar comprimido
Os dois ponteiros respectivamente exibem a pressão do reservatório de ar do freio principal para o eixo dianteiro e a pressão do reservatório de ar do freio principal para os eixos intermediário e traseiro.

 CUIDADO

Se as pressões dos reservatórios de ar estiverem abaixo de 0,55 MPa, a luz de aviso “Baixa pressão do freio” acenderá e a campainha emitirá alarme simultaneamente. Imediatamente pare o guindaste e desligue o motor. Caso contrário, é muito perigoso.

- c) Examinando a reserva de combustível
Exibição da quantidade de combustível no gráfico de barras em 1 ou 0
1 significa que o tanque de combustível está cheio. 0 significa que o tanque de combustível está vazio.

! CUIDADO

Se o ponteiro estiver próximo de “0”, reabasteça a reserva de combustível. Não dirija quando o tanque de combustível estiver vazio, ou o sistema de combustível terá que ser ventilado.

d) Examinando a temperatura do refrigerante

A temperatura do refrigerante é exibida no termômetro de água. Em condições normais, o ponteiro aponta para a faixa verde. O ponteiro apontará para a faixa vermelha ao dirigir em áreas de alta temperatura ou quando o operador estiver subindo encostas. A temperatura do refrigerante deve estar entre 70 °C - 101 °C. Não dirija o veículo em alta velocidade até que a temperatura do refrigerante atinja 70 °C.

! PERIGO

Se o ponteiro apontar para a faixa vermelha por muito tempo durante a condução, pare imediatamente o guindaste e examine o sistema de resfriamento do motor. Caso contrário, isso resultará em danos ao motor.

3.3.4 Operação de transmissão manual

O guindaste está equipado com uma transmissão principal e uma transmissão auxiliar. A transmissão principal é controlada mecânica e manualmente, e a auxiliar é controlada pneumaticamente.

A pressão de ar do câmbio de marchas deve ser superior a 0,41 MPa. Para detalhes, favor consultar a Figura 3-36.



Figura 3-36 Transmissão

3.3.4.1 Mudança de marchas

- Mova a alavanca de câmbio para a posição de 1ª marcha e coloque o interruptor “Pré-seleção da marcha alta/baixa” na marcha baixa antes de dar partida no veículo.
- Quando você mudar a marcha, desengate a embreagem completamente e coloque a alavanca de câmbio na posição.

- c) Tanto a marcha alta quanto a marcha baixa têm uma posição neutra, ou seja, a posição neutra entre a 7ª e a 8ª marcha na marcha alta e entre a 2ª e a 3ª marcha na marcha baixa. Mova a alavanca de câmbio para a posição neutra na marcha baixa ao estacionar o guindaste.
- d) Pare o veículo antes de mover a alavanca de câmbio para a marcha à ré para evitar danos à transmissão. Ao engatar a marcha à ré, aplique grande força para vencer a resistência da trava de ré.
- e) Não pule uma marcha ao mudar das marchas baixas para as marchas altas. Caso contrário, você reduzirá a vida útil do sincronizador da transmissão auxiliar.

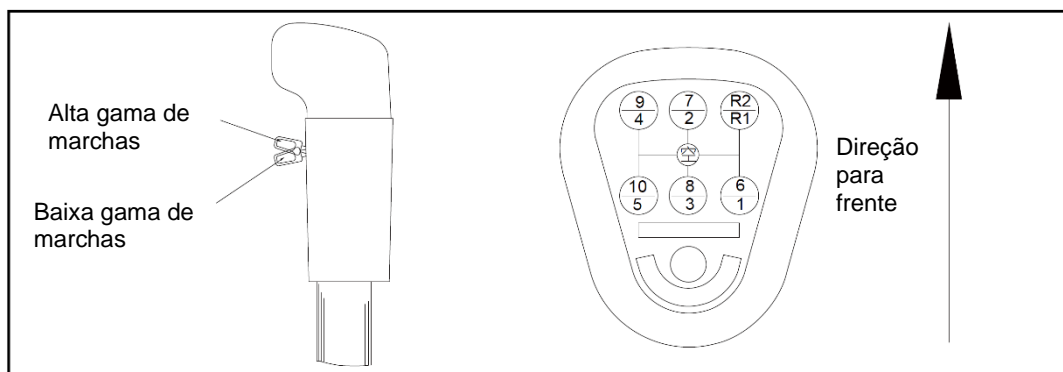

Você deve usar o interruptor “Pré-seleção da faixa de marcha alta/baixa” ao trocar a marcha entre as marchas 5 e 6.

- f) Ao descer uma ladeira, não mude a marcha entre as marchas alta e baixa.
- g) Quando você ouvir um ruído incomum na transmissão ou for difícil mover o volante, pare o guindaste imediatamente. Corrija qualquer avaria.
- h) Faça uma verificação do nível de graxa da transmissão após parar o veículo por vários minutos.



A temperatura da transmissão deve estar entre -40 °C – 120 °C durante o trabalho contínuo.

Quando a temperatura passar de 120 °C, a graxa irá se decompor e a vida útil da transmissão será reduzida.

3.3.4.2 Pontos de atenção

Pise no pedal da embreagem ao trocar as marchas. Ao reduzir a marcha, acelere na posição neutra para que as peças de conexão tenham a mesma velocidade de rotação.



Ao descer uma ladeira comprida, coloque a alavanca de câmbio em marchas baixas no tempo devido. Não movimente o veículo desligando o motor ou colocando a alavanca de câmbio em ponto morto.

3.3.4.3 Instruções operacionais para uma transmissão automática

O módulo de execução da transmissão é composto por uma unidade de controle da transmissão (TCU), válvula de mudança direcional, cilindro de mudança de marcha e sensor. A troca de marchas pode ser realizada automática ou manualmente.

O operador pode alternar entre o modo de mudança de marcha automática e manual pressionando a tecla <A/M> na alavanca.

O modo de mudança atual será exibido no painel de instrumentos ou no visor LML. O modo padrão é o modo de mudança automática.

a) Modo de mudança automática (A)

- 1) Nesse modo, o AMT selecionará automaticamente uma posição de marcha e mudará para a marcha de acordo com a condição operacional do veículo.
- 2) O operador também pode mudar de marcha usando a alavanca de câmbio.
- 3) Pressione e segure o botão "F" (funcional) e mova a alavanca para frente ou para trás para aumentar ou diminuir uma marcha.
- 4) Empurre diretamente a alavanca para frente ou para trás para aumentar ou diminuir uma posição de marcha.
- 5) Pressione o botão F várias vezes (cada pressão corresponde a uma posição de marcha para cima ou para baixo), solte-o e empurre a alavanca para frente ou para trás, para mudar para a posição de marcha desejada, se for adequada. Se não for adequada, o sistema selecionará automaticamente uma posição de marcha adequada.



A posição de marcha selecionada pelo operador só pode ser executada quando estiver de acordo com as condições operacionais atuais do veículo. O controle de mudança de marcha manual só pode funcionar durante um curto período de tempo, ou seja, o modo de mudança de marcha automática não será encerrado sob interferência manual do operador.



Figura 3-37 Alavanca de mudança de transmissão

F: tecla funcional

N: botão de marcha neutra (retornar à posição neutra) UP: empurre a alavanca para frente para aumentar uma marcha pesada: puxe a alavanca para trás para diminuir uma marcha L: modo de baixa velocidade

E/P: alternar entre o modo ECO e o modo power A/M: alternar entre o modo de mudança automática e manual

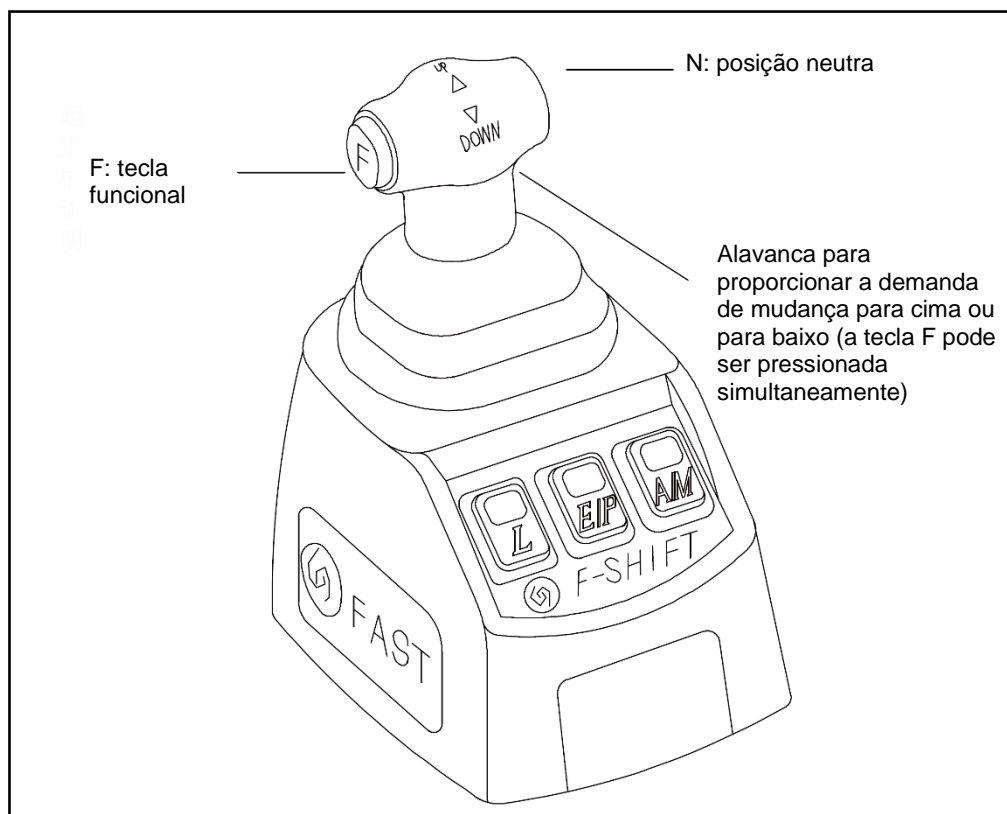
Uma FAST AMT (Transmissão Manual Automatizada) é usado para este guindaste. A alavanca de mudança de marchas é mostrada na Figura 3-37. Esta alavanca pode ser usada para alternar entre o modo de mudança de marcha automática e manual e mudar a posição da marcha etc.

b) Modo de mudança manual (M)

- 6) No modo de mudança manual, a posição da marcha é selecionada pelo operador.
- 7) Pressione e segure a tecla funcional F e empurre a alavanca para frente ou para trás para aumentar ou diminuir uma marcha.
- 8) Empurre diretamente a alavanca para frente ou para trás para aumentar ou diminuir uma posição de marcha.
- 9) Pressione o botão F várias vezes (cada pressão corresponde a uma posição de marcha para cima ou

para baixo), solte-o e, em seguida, empurre a alavanca para frente ou para trás, para mudar para a posição de marcha desejada, se for adequada. Se não for adequada, o sistema selecionará automaticamente uma posição de marcha adequada.

10) A troca de marchas e o controle da embreagem são realizados automaticamente pelo sistema AMT.

! CUIDADO

Se a posição de marcha selecionada pelo operador não se adequar às condições operacionais atuais do veículo, a AMT recusará tal solicitação de troca de marcha ou mudará automaticamente para uma posição de marcha mais adequada.

! CUIDADO

A temperatura de trabalho da transmissão deve estar dentro da faixa de -40 °C - 120 °C, caso contrário, seu lubrificante se decomporá, resultando em menor vida útil da transmissão.

c) Indicação de falha

O painel pode exibir as informações atuais do AMT, conforme mostrado na Figura 3-38.



Figura 3-38 Indicação da engrenagem de transmissão

A posição "A" exibe A ou M; A posição "E" exibe E ou P;

A posição "2" exibe a marcha atual ("N" para ponto morto; R1~R2 para marcha à ré; 1~16 para marcha à frente).

A posição "4" exibe a marcha selecionada. A seta para cima significa operação de mudança de marcha para cima; a seta para baixo significa operação de redução de marcha para baixo.

Quando ocorre uma falha do AMT, a luz de aviso acende no painel, conforme mostrado na Figura 3-39.



Figura 3-39 Indicação de falha da engrenagem de transmissão

Conforme mostrado na Figura 3-39, a posição atual da marcha é neutra e a posição alvo da marcha é a 5ª marcha. Quando não houver falha, a luz de fundo fica verde; quando houver uma falha, a cor de fundo muda de acordo com as seguintes regras:

- 1) Falha grave: a luz de fundo fica vermelha e a campainha toca continuamente; As informações de falha do AMT aparecem no painel de instrumentos. O veículo deve ser parado imediatamente e não pode ser conduzido antes que a falha seja corrigida!
- 2) Falha geral: a luz de fundo é amarela e a campainha toca por 20 s e depois para. Informações de falha são exibidas no painel de instrumentos. O guindaste ainda pode ser conduzido, mas a falha precisa ser corrigida o mais rápido possível.

Consulte o *Manual do Operador da Transmissão 10JZSD200A* para o significado dos códigos de falha.

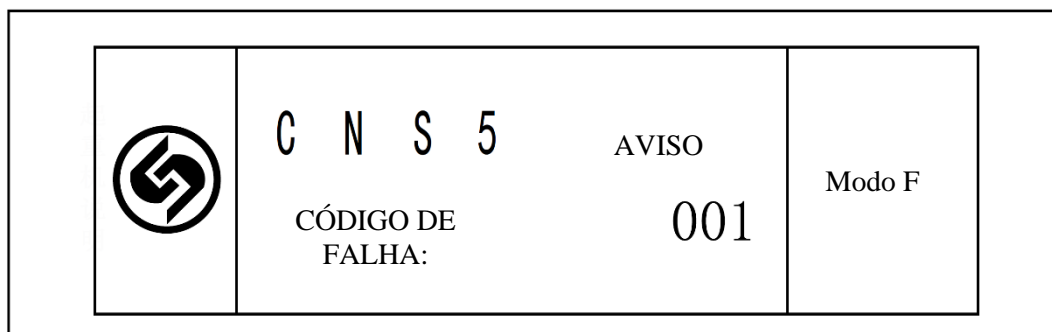
d) Modo E/P

- O modo econômico <E> e o modo de potência <P> são válidos somente quando o AMT estiver funcionando no modo de mudança automático <A>;
- No modo de potência, a troca automática de marchas do AMT visa fornecer a potência máxima, obtendo o mais alto desempenho de aceleração.
- No modo econômico, a troca automática de marchas do AMT visa atingir o menor consumo de combustível.
- Quando o guindaste estiver sendo conduzido por uma longa distância ou em um longo declive com carga pesada, é altamente recomendável ativar o modo de energia <P>.

- 1) Tanto o modo de energia quanto o modo econômico oferecem vantagens, mas apenas um modo pode ser ativado por vez. O operador pode alternar entre esses dois modos usando a chave de comutação E/P na alavanca.
- 2) O modo de operação atual será exibido em tempo real. O modo padrão é o modo econômico. Pressione o interruptor de comutação E/P para alternar para o modo de energia; pressione o interruptor novamente para retornar ao modo econômico.

e) Modo de baixa velocidade (L)

- 1) Este modo deve ser usado quando o guindaste estiver muito sobrecarregado ou para auxiliar na partida do veículo em superfícies macias ou lamacentas.

- 2) Quando o veículo for deslocado neste modo, o sistema AMT exigirá que o motor atinja uma velocidade comparativamente alta antes que a embreagem seja engatada e o veículo se desloque.
- 3) Este modo só pode ser ativado pela tecla funcional (L) quando a alavanca de câmbio estiver na posição R1, N, 1, 2, 3 e 4. Após este modo ser ativado, a 4ª marcha é a posição de marcha mais alta e R1 é a única posição de marcha à ré.
- 4) Pressione a tecla L novamente para sair deste modo.

 **CUIDADO**

Quando o veículo arranca neste modo, devido à alta rotação do motor, o desgaste da embreagem aumenta. Portanto, este modo deve ser usado conforme necessário e não com frequência para evitar o desgaste prematuro da embreagem.

- f) Consulte o *Manual do Operador da Transmissão 10JZSD200A* para outras instruções operacionais relativas à transmissão.

 **AVISO**

1. **Não engate a posição neutra antes de o veículo parar completamente.**
2. **Durante o deslocamento do veículo, se a alavanca de câmbio mudar para a posição neutra, a transmissão de força será interrompida e o freio do motor não funcionará.**

3.3.5 Operação da embreagem (não aplicável a um AMT)

No sistema de acionamento, a embreagem é uma peça diretamente ligada ao motor. Sua função é engatar ou desengatar efetivamente suas partes de acionamento e acionadas sob a operação do operador.

3.3.5.1 Pontos de atenção

- a) Durante a condução, não coloque o pé no pedal da embreagem se não estiver utilizando a mesma.
- b) Ao reduzir a marcha, pise no pedal do freio de serviço para desacelerar o veículo e, em seguida, pise no pedal da embreagem corretamente para mudar para a marcha adequada.

 **CUIDADO**

Ao mudar de marcha durante a condução, pise e solte o pedal da embreagem rapidamente. Caso contrário, existe o risco de aumentar a abrasão da embreagem.

- c) Não pise no pedal da embreagem até o máximo, exceto se for frear em baixa velocidade.

 **CUIDADO**

Somente quando a pressão de ar comprimido P estiver acima de 0,4 MPa, a

embreagem pode ser completamente desengatada.

3.3.6 Operação de direção

- a) Ao entrar em uma curva, olhe ao redor antes de virar o volante. Gire o volante após certificar-se de que é seguro se mover. Em seguida, coloque a transmissão em uma marcha mais baixa e aplique uma pequena quantidade de pressão no freio de serviço.
- b) O volante possui um limite mecânico. Não continue a girar a roda quando tiver atingido o limite. Não mantenha a roda no limite por mais de 5 segundos.
- c) Se a direção do veículo for insuficiente, diminua a velocidade lentamente enquanto gira o volante na mesma direção da curva.
- d) Em caso de esterçar além da conta, solte o pedal de controle do motor ou pise no pedal do freio de serviço enquanto gira o volante na direção oposta da curva.



Não gire o volante rapidamente em uma direção, a menos que seja uma emergência. Faça suas curvas suavemente para manter o guindaste lateralmente estável. Ao completar a curva, imediatamente volte o volante levemente para a posição neutra para evitar uma condição instável.

- e) Diminua a velocidade do veículo e diminua a marcha de transmissão se tiver uma curva fechada.

3.3.7 Operação de freio

O sistema de freio é composto por freio de condução (freio de serviço), freio motor e freio de emergência (freio de estacionamento). O freio de emergência também pode ser selecionado para estacionar o veículo em condições normais e em declives.

3.3.7.1 Operação

- a) Freio de condução

Existem vários casos de frenagem. Para detalhes, favor consultar as instruções a seguir:

- 1) Freio normal durante a condução, solte o pedal de controle do motor à frente para desacelerar o veículo de acordo com as condições reais da estrada (em relação à superfície da estrada, tráfego, etc.) e, então, pise contínua ou intermitentemente no pedal de freio de serviço para diminuir a velocidade de maneira estável ou parar o veículo.
- 2) Freio lento após frenagem rápida: em caso de acidente à frente, pise rapidamente no pedal do freio de serviço e, em seguida, pise de novo lentamente. Solte o pedal lentamente de acordo com a distância do local do acidente e mude a marcha de acordo com a velocidade real de condução. Por fim, pise no pedal de controle do motor para dirigir em velocidade normal.
- 3) Freio de cadência: pise no pedal do freio de serviço e solte-o. Repita a operação

para desacelerar o veículo gradualmente. A operação deve ser muito suave.

- 4) Freio rápido: em caso de emergência repentina, solte imediatamente o pedal de controle do motor e pise no pedal do freio de serviço com força (às vezes, acione o freio de estacionamento ao mesmo tempo) para parar o veículo o mais rápido possível. Assim, o acidente será evitado.

 **CUIDADO**

Quando você faz muitas paradas com frenagens bruscas, o pneu, o tambor de freio e a lona do freio se desgastam prematuramente e a vida útil de cada peça diminui. Tenha mais cuidado quando as estradas estiverem molhadas ou congeladas.

- b) Freio motor

Ao dirigir o veículo em uma descida extensa, use o freio motor. O veículo desacelera por meio do motor em vez do freio de serviço.

O freio motor oferece as vantagens abaixo:

- Melhora a segurança de condução.
- Garante o desempenho do freio e evita falha do freio.

Nota:

Ao pisar no pedal do freio de serviço com frequência, o tambor de freio será superaquecido.

Como ativar o freio motor:

- Solte o pedal de controle do motor.
- Mova o interruptor da coluna de direção do lado direito para trás.

Resultado:

- O freio motor é ativado e a luz de controle "Freio motor" acende.

 **CUIDADO**

Você pode pressionar o pedal da embreagem ou o pedal de controle do motor para desativar temporariamente o freio de escape do motor.

- c) Freio de emergência (freio de estacionamento)

Se o freio de serviço falhar ou não puder ser aplicado a tempo durante a condução, puxe a alavanca manual do freio de estacionamento para trás até a posição de travamento para ativar o freio de emergência. Empurre a alavanca manual para a frente para a posição de destravamento para desativar o freio de emergência.

 **CUIDADO**

- (1) **Você também pode utilizar o freio de emergência (freio de estacionamento) para estacionar o veículo em condições normais ou em declives.**

(2) Desative o freio de emergência antes de dirigir.**3.3.7.2 Pontos de atenção**

- a) Depois que o pedal de controle do motor for liberado durante a condução, não pise no pedal do freio de serviço quando não houver necessidade de frear o veículo.
- b) Não acione o freio de emergência quando o veículo estiver sendo conduzido em estradas estreitas, congeladas ou lamacentas ou em um dia chuvoso/nevado. Nessas condições, como atravessar uma ferrovia, dirigir embaixo de uma ponte ou dirigir em uma estrada com poças de água, ou um lado do veículo estiver sendo conduzido em uma estrada congelada ou lamacenta, evite aplicar o freio de serviço o máximo possível. Caso contrário, o veículo pode ser desligado repentinamente.
- c) Após atravessar uma estrada com poças de água, pressione o pedal do freio de serviço várias vezes para eliminar a água na sapata de freio e garantir o desempenho do freio.
- d) Antes de dirigir em um longo declive, coloque a alavanca de câmbio na marcha baixa. Nesta condição, a velocidade de condução é controlada principalmente pela resistência à tração do motor e com a ajuda do freio motor e do freio de serviço. Não movimente o veículo com a transmissão na posição neutra.
- e) Quando o freio de estacionamento for usado como freio auxiliar, não puxe a alavanca manual para sua posição limite. Ao estacionar o veículo em qualquer condição, puxe a alavanca do freio de estacionamento para a posição de travamento, especialmente se estiver estacionando o veículo em um declive. Caso contrário, há risco de ferimentos fatais e acidentes!
- f) O intervalo adequado de troca do líquido de freio deve ser de 12 meses ou 10.000 km.
- g) O intervalo entre pressionar o pedal do freio até a câmara de freio mais adversa é de 0,55 s.

3.3.8 Operação da tomada de força**3.3.8.1 Engatando a tomada de força para uma transmissão manual**

Consulte a Figura 3-40.

- a) Abra a válvula de bloqueio no tanque de óleo hidráulico para conectar o tanque de óleo hidráulico e as linhas de óleo.
- b) Dê partida no motor.
- c) Examine o barômetro para ver se a pressão do ar está entre 0,6 e 0,8 MPa após o motor funcionar de forma estável.
- d) Pise no pedal da embreagem.
- e) Acione o freio de estacionamento e mova a alavanca de câmbio para a posição neutra.
- f) Puxe o interruptor da tomada de força para engatar a tomada de força e, em seguida, a luz de controle "Tomada de Força engatada" acende.
- g) Solte lentamente o pedal da embreagem e o guindaste está pronto para trabalhar.



Figura 3-40 Engatando a tomada de força

3.3.8.2 Desengatando a tomada de força

Consulte a Figura 3-41.

- Pise no pedal da embreagem.
- Coloque a alavanca de câmbio na posição neutra. Pressione o interruptor da tomada de força para desativar a tomada de força e, em seguida, a luz de controle I "Tomada de Força engatada" se apaga.
- Solte o pedal da embreagem lentamente e, em seguida, o guindaste estará em estado de inatividade.

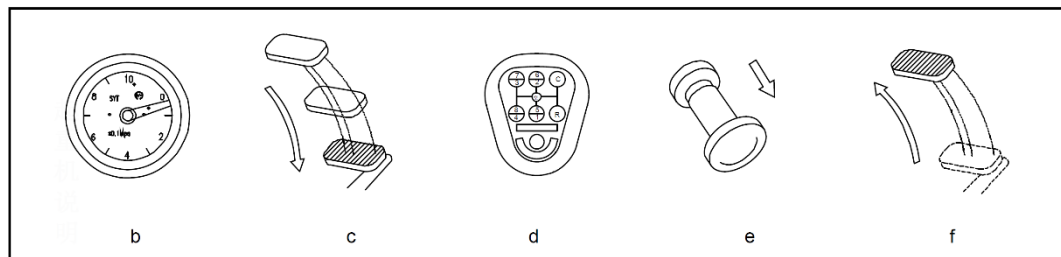

Figura 3-41 Desengatando a tomada de força

! CUIDADO

- Pressione e solte o pedal da embreagem lentamente.
- Se a tomada de força e o dispositivo de acionamento da bomba de óleo tiverem que ser reparados ou substituídos, coloque uma placa de aviso no botão de ignição. Caso contrário, existe um risco de operação!

! AVISO

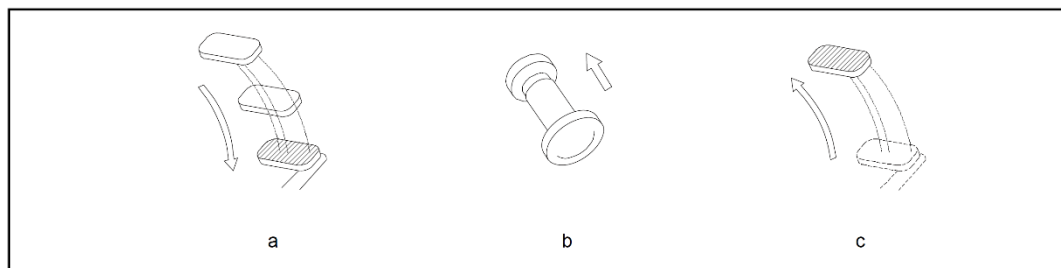
Quando a tomada de força estiver engatada, mantenha a alavanca de câmbio na posição correta e acione o freio de estacionamento.

3.3.8.2 Operação da tomada de força para o AMT

Este AMT engata a tomada de força em ponto morto. Antes de acionar a tomada de força, o operador deve confirmar se o guindaste está parado, o freio de estacionamento está acionado e a pressão do ar do veículo completo é superior a 8Bar.

Acionar a tomada de força conforme as seguintes etapas:

- a) a) Engate uma marcha.
- b) Após engatar a marcha, ligue o interruptor da tomada de força;
- c) Aguarde até que a luz indicadora da tomada de força no painel de instrumentos acenda e coloque a alavanca de câmbio na posição neutra.
- d) Após cerca de 5 s, a tomada de força é engatada. Desengatar a tomada de força conforme as seguintes etapas:
 - a) a) Engate uma marcha;
 - b) Desligue o interruptor da tomada de força;
 - c) Após a luz indicadora da tomada de força se apagar, coloque a alavanca de câmbio de volta na posição neutra.

3.3.9 Reboque

Há um acoplamento de reboque nas extremidades dianteira e traseira do guindaste. Obedeça aos seguintes regulamentos de reboque:

- a) Acople um cabo de reboque forte no acoplamento de reboque na frente embaixo do para-choques. Comece devagar para evitar o impacto.
- b) Dê partida no motor do veículo rebocado para certificar-se de que ele pode realizar a operação de freio e direção de emergência. Caso contrário, será muito perigoso.



AVISO

Se o motor do guindaste rebocado não funcionar, não reboque o guindaste.

- c) Mova a alavanca de câmbio do guindaste rebocado para a posição neutra.
- d) Se a transmissão do guindaste rebocado quebrar, remova o eixo da hélice.
- e) Se a engrenagem diferencial ou o eixo traseiro do guindaste rebocado estiver com defeito, remova os semi-eixos esquerdo e direito.



CUIDADO

O sistema de freio motor ficará inválido se você remover o eixo da hélice ou o meio eixo.

3.3.10 Concluindo as operações de condução

- a) Parando
 - 1) Freie o guindaste até que ele pare.
 - 2) A faixa de acionamento selecionada pode permanecer ligada.
 - 3) Use o freio de serviço ou o freio de estacionamento para garantir que o guindaste não se mova.



CUIDADO

Se você parou o guindaste por mais de 1 minuto, mude a transmissão para a posição neutra para evitar desgaste na embreagem. Não deixe o motor funcionar em marcha lenta por muito tempo.

- b) Parando o veículo com o motor em funcionamento
 - 1) Freie o guindaste até ele parar.
 - 2) Coloque a transmissão na posição neutra.
 - 3) Acione o freio de estacionamento e a luz de controle “Freio de estacionamento fechado” acende.

3.3.11 Códigos de erro do motor e diagnóstico de falhas

3.3.11.1 Auto-diagnóstico

A ECU do motor Weichai é de função de diagnóstico. Se a ECU detectar erros ocorridos no sistema de controle elétrico, ela irá:

- enviar códigos de erro e armazená-los.
- acender a luz de aviso.
- ativar automaticamente diferentes medidas de proteção.
 - Se a luz de aviso “Defeitos do motor” acender, isso indica que o motor está com defeito. Pare o guindaste e repare até que a luz de aviso se apague.
 - Se a luz de aviso “Defeitos do motor” não acender, mas o código de erro ainda for exibido, isso indica códigos de erro armazenados ou defeito não muito grave que não afetará a operação normal.
 - Na maioria das circunstâncias, a medida de proteção ativada diminuirá a rotação do motor para garantir que o motor funcione com falha (o modo “Limp home”). No entanto, a falha grave levará ao desligamento do motor.

3.3.11.2 Leia os códigos de erro do motor

- Leia os códigos de erro do sistema de diagnóstico de falhas.
- Leia os códigos de erro pela luz de aviso “Código de erro do motor exibido”.
 - Pressione e solte o botão “Diagnóstico de falha do motor”. Os códigos de erro piscarão na luz de aviso “Código de erro do motor exibido”. Consulte a *Lista de códigos intermitentes* para informações detalhadas.
 - A ECU pode armazenar 10 códigos de erro.
Um código intermitente consiste em 3 números digitais. Cada número digital pisca a cada 1 segundo, como 3—2—1.



Figura 3-42 Exibição do código de erro do motor



Se o botão “Diagnóstico de falha do motor” for ativado, a luz de aviso “Código de erro do motor exibido” acenderá.

- Apague o erro armazenado:
 - 1) Pressione o botão “Diagnóstico de falha do motor”.
 - 2) Ligue o botão de partida (T15).
 - 3) Segure o botão “Diagnóstico de falha do motor” por 4 a 8 segundos e depois solte.
 - 4) Desligue o disjuntor próximo à bateria para desengatar a ECU.
 - 5) Dê partida no motor novamente.

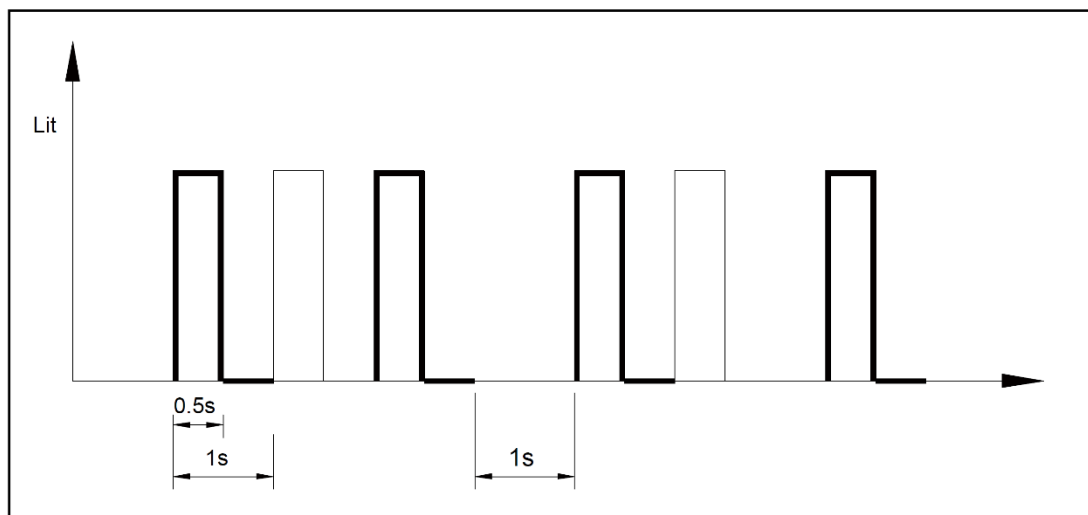

- (1) **Apenas o erro armazenado pode ser apagado. O erro atual não pode ser apagado. Antes de eliminar o erro armazenado na ECU, resolva primeiro o erro atual.**
- (2) **Se os códigos de erro não puderem ser apagados, entre em contato com nosso técnico de serviço o mais rápido possível.**

3.4 Pontos de atenção

3.4.1 Condução na estrada

- a) Não pule uma marcha ao passar pelo ciclo de marchas.
- b) Pare o veículo se houver condições incomuns com os itens da lista abaixo:
 - Direção
 - Frenagem
 - Sons ou cheiros

- Vibrações
- Aumento ou diminuição repentina da velocidade.

Se você não conseguir encontrar ou corrigir o problema, envie o veículo para reparo.

- c) Não opere um veículo se uma luz de aviso acender. Pare o veículo e conserte-o.
- d) Examine os seguintes instrumentos para funções:
 - Barômetro
 - Medidor pressão do óleo do motor
 - Termômetro de água etc.
- e) Coloque o guindaste em uma marcha mais baixa antes de subir uma ladeira para diminuir a carga no motor e na linha de transmissão.
- f) Tome essas medidas antes de descer uma longa ladeira:
 - Certifique-se de que o sistema de freio pode parar o guindaste antes de subir a ladeira.
 - Coloque a transmissão em marcha baixa antes de descer a ladeira. Acione o freio motor.
 - Evite que o motor acelere. O funcionamento excessivo do motor se refere ao fenômeno de que o motor acionado pela roda funciona na rotação que excede sua rotação máxima nominal do motor.



- (1) **O motor é facilmente danificado por excesso de funcionamento.**
 - (2) **Desacelere o guindaste antes de reduzir a marcha. Ao reduzir a marcha a partir da posição da 4ª marcha, a rotação do motor deve estar abaixo de 1500 r/min. Ao reduzir a marcha da posição da 3ª marcha, a RPM deve estar abaixo de 1200 r/min. Caso contrário, pode ocorrer sobrecarga do motor.**
- g) Se o motor parar porque o tanque de combustível está vazio, o ar pode entrar no sistema de combustível. Se isso ocorrer, sangre o ar das linhas de combustível.
 - h) Quando o guindaste entra em um terreno acidentado, como uma ladeira, conduza o guindaste lentamente para evitar o deslizamento dos pneus devido ao atrito insuficiente entre os pneus dos eixos 3 e 4 e o solo. Quando o guindaste dá ré em um declive etc., ele pode parar de se mover devido ao deslizamento do pneu causado por tal falta de



atrito.

Não deixe o veículo avançar depois que o motor estiver DESLIGADO.

3.4.2 Movimentos do guindaste em condições fora de estrada

Quando os eixos estiverem na lama (sem tração) ou em terrenos acidentados, siga estes passos:

- a) Adicione travas dos diferenciais transversal e longitudinal.

- b) Coloque a alavanca de câmbio na marcha baixa e, em seguida, engate a embreagem lentamente. Caso contrário,

a vida útil do guindaste será reduzida.

- c) Certifique-se de que a rotação do motor esteja próxima do máximo.
- d) Reboque o veículo ou coloque materiais rígidos, por exemplo, pedaços de madeira ou chapas de ferro, abaixo das rodas.

3.4.3 Estacione o veículo

- a) Ao estacionar o veículo, siga as instruções abaixo:
 - 1) Em condições de mau tempo (chuva, neve, gelo) ou em um declive, certifique-se de que haja bastante espaço na frente e atrás do veículo.
 - 2) Acione o freio de estacionamento. Sempre coloque calços antes e atrás das rodas em um declive.
 - 3) Mova a alavanca de câmbio para a posição neutra da marcha baixa.
- b) Antes de desligar o motor, tome as seguintes medidas:
 - 1) Pise no pedal de controle do motor 2 ou 3 vezes para aumentar a rotação do motor. Isso faz com que o óleo flua por todo o motor.
 - 2) Deixe o motor em marcha lenta enquanto monitora a temperatura do refrigerante.
 - 3) Desligue o motor quando a temperatura do refrigerante estiver na faixa correta.

CUIDAD

- (1) **Certifique-se de que as luzes de perigo estejam acesas quando o veículo estiver estacionado na estrada à noite.**
- (2) **Se demorar 1 minuto ou mais para estacionar o veículo, coloque a alavanca de câmbio em ponto morto para diminuir o desgaste da embreagem. Não deixe o motor funcionar em marcha lenta por muito tempo.**

3.4.4 Parada de emergência na estrada

Se o guindaste apresentar defeito na estrada, tome as seguintes medidas:

- a) Pare o guindaste em um local seguro.
- b) Ligue as luzes de perigo e coloque o triângulo de advertência na posição.
- c) Acione o freio de estacionamento se você parar devido a uma falha no trem de força (eixo de transmissão, eixo) ou fizer uma parada de emergência em um declive. Coloque calços antes e atrás das rodas.
- d) Examine o veículo para encontrar a peça que causou o mau funcionamento. Cuidado com as condições da estrada enquanto caminha ao redor do veículo.

Se não conseguir reparar o veículo, informe o serviço de assistência e reparo.

ZOOMLION

Manual do operador de caminhão
guindaste

Capítulo 4 Operação - Superestrutura do guindaste



Capítulo 4 Operação – Superestrutura do guindaste

4.1 Cabine do operador

4.1.1 Visão geral



Figura 4-1 Interior da cabine

Pos.	Descrição	Pos.	Descrição	Pos.	Descrição
1	Painel de controle A/C	2	Painel de interruptor auxiliar	3	Monitor
4	Joystick direito	5	Limitador de momento de carga	6	Painel de interruptor
7	Pedal de controle de motor	8	Assento do operador	9	Joystick esquerdo

4.1.2 Painel de instrumentos

Para painel de instrumentos, consulte a figura 4-2.

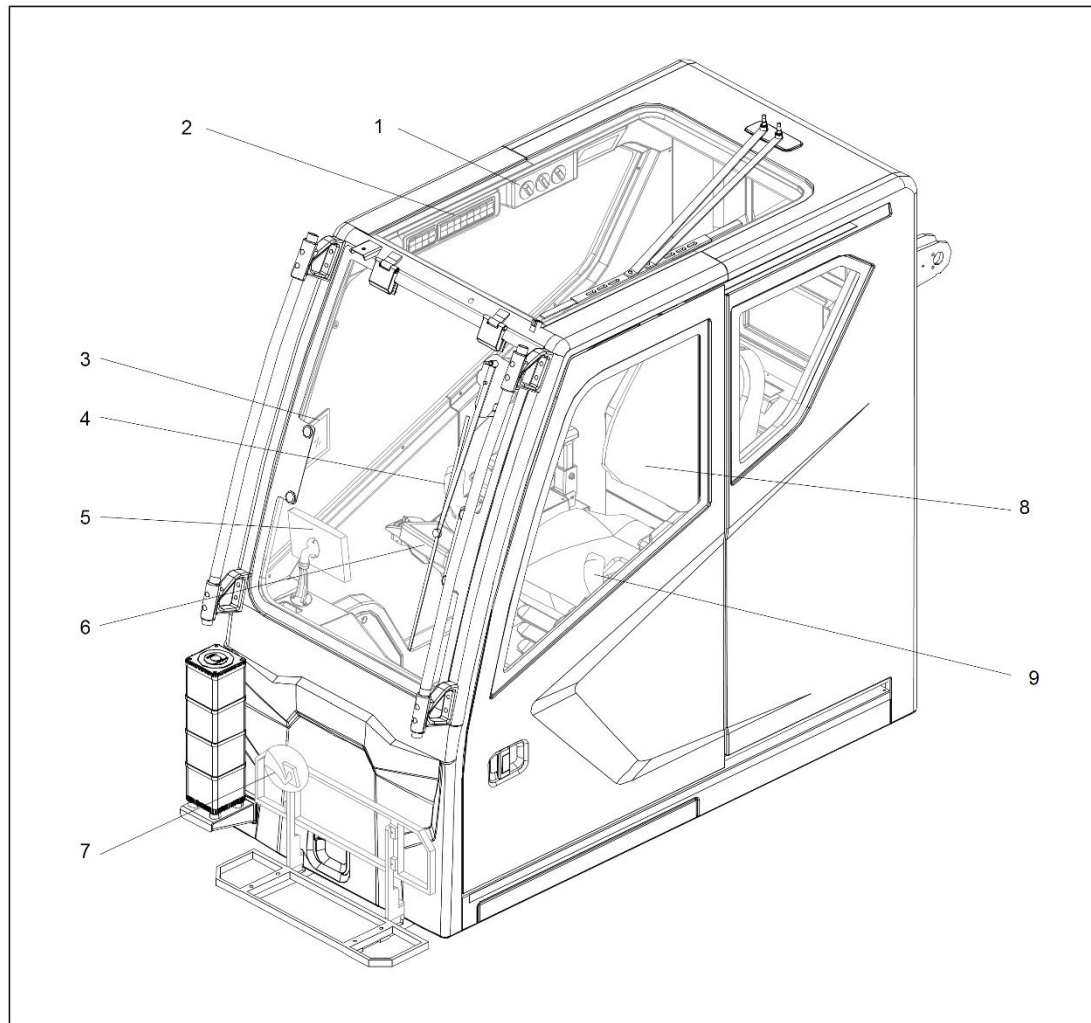

Figura 4-2 Painel de instrumentos

Pos.	Descrição	Pos.	Descrição
1	Isqueiro	2	Botão de parada de emergência

1 Isqueiro

Aperte o isqueiro por vários segundos. Puxe para usá-lo.

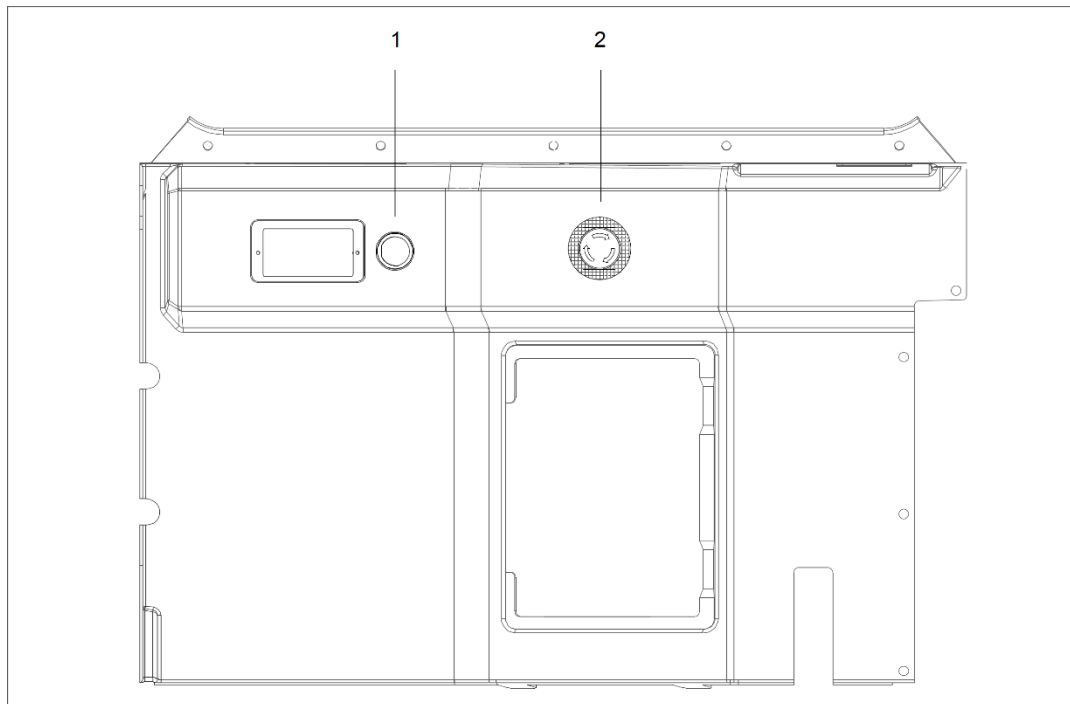
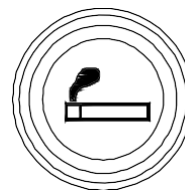

2 Botão de parada de emergência pressionado:

Todos os movimentos da superestrutura são cortados.

Use o botão em uma emergência clara, para prevenir perda de propriedade e mortes.

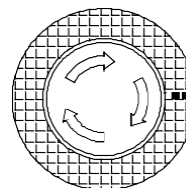

4.1.3 Painel de interruptor



Figura 4-3 Painel de interruptor

Pos.	Descrição	Pos.	Descrição
1	Botão de parada do motor	5	Botão homem morto
2	Botão PTO	6	Botão controle remoto de contrapeso
3	Botão de aumento de RPM de motor	7	Botão resfriador de óleo
4	Botão de diminuição de RPM de motor	8	Botão (não utilizado) sistema de lubrificação central

Pos.	Descrição	Pos.	Descrição
9	Botão Pré-seleção de velocidade normal/velocidade intermediária/velocidade baixa	15	Botão Telescopagem manual
10	Interruptor de modo de avanço	16	Botão Operação de pino de cilindro
11	Interruptor de confluência	17	Botão Cabine do operador inclinada para baixo
12	Botão Operação de pino de lança	18	Botão Cabine do operador inclinada para cima
13	Botão Pré-seleção de grua/telescópio	19	Botão não utilizado
14	Botão Telescopagem automática	20	Botão não utilizado

1 Botão de parada do motor pressionado:

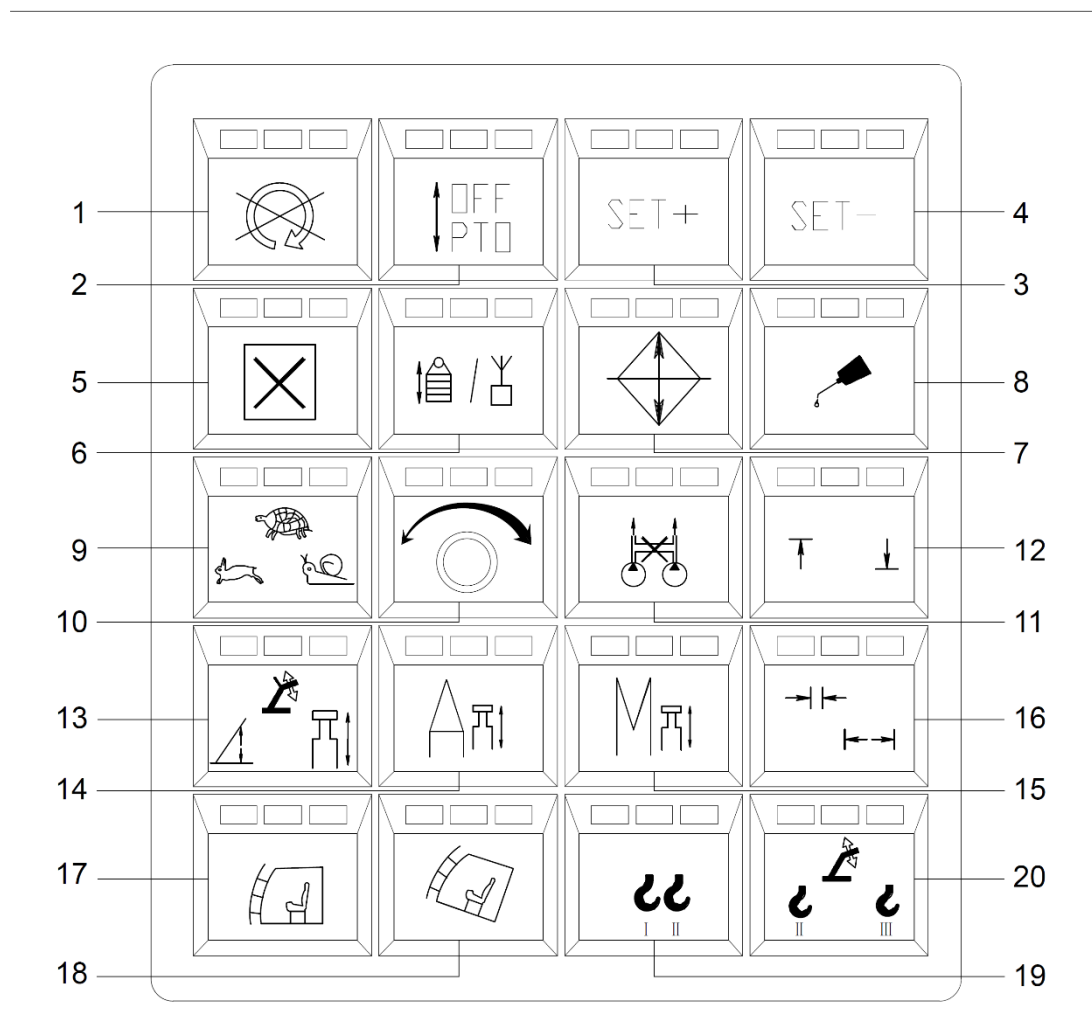
A luz do meio fica vermelha.

Quando PTO estiver ativado e a superestrutura operar, o motor para.

Esse botão também pode controlar o filtro de combustível multifuncional no chassi, para funcionar novamente após o filtro de combustível multifuncional parar de funcionar.



2 Botão PTO pressionado uma vez:

A luz do meio acende. Ative PTO.

RPM do motor da superestrutura aumenta para 900 r/min.

Pressionado duas vezes:

A luz do meio fica vermelha. Desative PTO.

RPM do motor diminui até a velocidade sem carga.

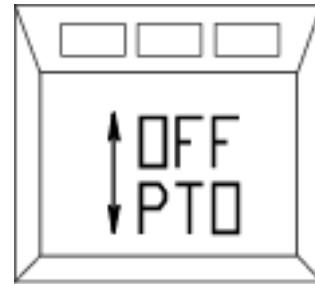

Ative PTO antes de iniciar uma operação de levantamento.

Não levante enquanto PTO estiver desativado.

3 Botão**Aumentar RPM do motor pressionado:**

A luz do meio fica vermelha.

RPM do motor aumenta em 150 r/min., até 1350 r/min. ser atingido. (sequência: 900 r/min. → 1050 r/min. → 1200 r/min. → 1350 r/min.) após PTO ser ativado.

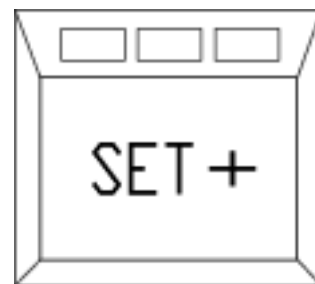
**4 Botão****Diminuir RPM do motor pressionado:**

A luz do meio fica vermelha.

RPM do motor diminui em 150 r/min., até 900 r/min. ser atingido. (sequência: 1350 r/min. → 1200 r/min. → 1050 r/min. → 900 r/min.) após PTO ser ativado.

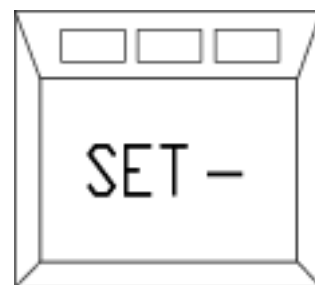

5 Botão homem morto pressionado:

A luz de controle do meio acende.

Opere as funções dos joysticks.

Ela tem a mesma função que os interruptores de homem morto nos joysticks esquerdo e direito.

Pressione o botão ou interruptor de homem morto para operar os joysticks.

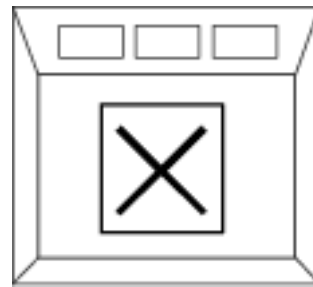

**Desative o botão após a operação.
Caso contrário, há risco de perdas inestimáveis!**

**6 Botão**

Controle remoto de contrapeso pressionado:

A luz esquerda acende.

É possível operar o contrapeso via controle remoto.

Pressionado três vezes:

Quando essas três luzes apagarem, o controle remoto para de funcionar. Os joysticks na cabine do operador realizam sua função.

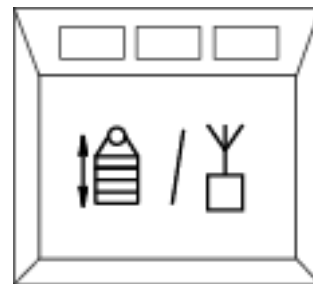
**7 Botão resfriador de óleo pressionado:**

O resfriador de óleo começa a operar.

Quando uma das condições a seguir for atendida, o resfriador de óleo opera.

– O motor dá partida e o botão resfriador de óleo é pressionado.

– O motor dá partida e a temperatura do óleo hidráulico ultrapassa 50°C.

Quando a temperatura do óleo hidráulico for inferior a 46°C, o

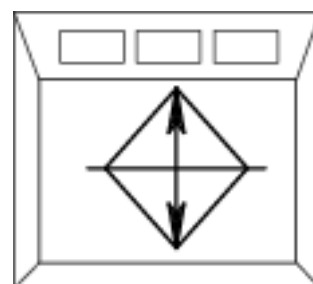

resfriador de óleo para automaticamente.

8 Botão

Sistema de lubrificação central

Esse veículo não suporta essa função.

9 Botão

Pré-seleção de velocidade normal/velocidade intermediária/velocidade baixa

- (1) Os movimentos do guindaste “giro” e “elevação” têm 3 velocidades que dependem da posição do interruptor.
- (2) Os movimentos de guindaste de “telescópio” têm 2 estágios em baixa velocidade:
 - (extremamente lento): desvia intermediariamente o joystick para a direita/esquerda
 - (lento): desvia totalmente o joystick para a direita/esquerda.
- (3) Os movimentos de “grua” do guindaste também têm 3 velocidades.

Considerando a controlabilidade, as velocidades dos movimentos do guindaste de “grua” e “giro” se limitam automaticamente à faixa de segurança quando o comprimento da lança for igual ou superior ao mais moderado.

10 Botão

Modo de avanço

Quando este botão é pressionado, a luz indicadora do meio acende

Velocidade de giro, grua, bobinamento e aceleração de guinchos principais e auxiliares podem ser ajustados de modo

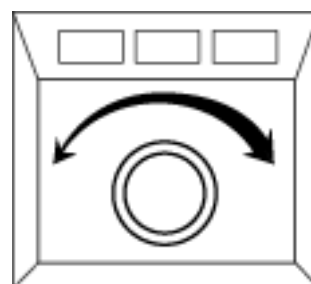

contínuo, utilizando o ligamento de ajuste de velocidade no painel de controle do joystick esquerdo obtendo dessa forma movimentos mais finos.

11 Botão de confluência

Quando este botão é pressionado, a luz indicadora do meio acende
Vazões de óleo hidráulico da bomba principal e bomba de giro são convergidas, o que acelera os movimentos de telescopagem de lança.
Quando esse interruptor for pressionado, a operação de giro é inválida.

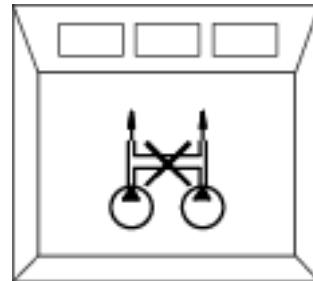

12 Botão

Operação de pino de lança

Modo de telescopagem manual: ative o interruptor até a luz direita acender, para realizar operação de retração de pino de lança; ative o interruptor até a luz esquerda acender, para realizar a operação de extensão de pino de lança.

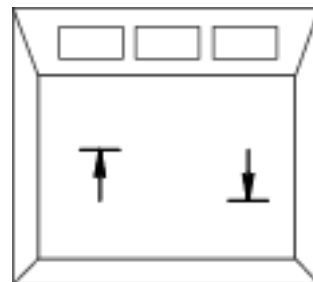

13 Botão

Pré-seleção de grua/telescópio pressionado:

- (1) A luz esquerda acende: O movimento de grua da lança está operacional
- (2) A luz direita acende: O movimento de telescopagem da lança está operacional
- (3) A luz do meio acende: Não utilizado. Esse veículo não suporta essa função.



14 Botão de telescopagem automática pressionado:

A luz do meio acende.

A lança pode realizar telescopagem automática.

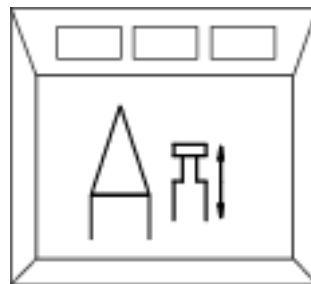
**15 Botão de telescopagem automática pressionado:**

A luz do meio acende. A lança pode realizar telescopagem manual.

**16 Botão Operação de pino de cilindro**

Modo de telescopagem manual: ative o interruptor até a luz esquerda acender, para realizar operação de retração de pino de lança. ative o interruptor até a luz direita acender, para realizar a operação de extensão de pino de lança.

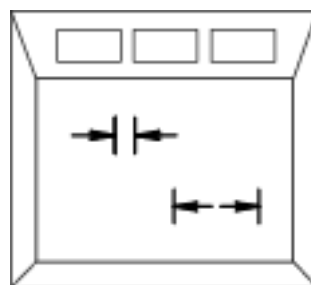
**17 Botão de cabine do operador inclinada para baixo pressionado:**

A luz do meio acende. Incline a cabine para baixo.

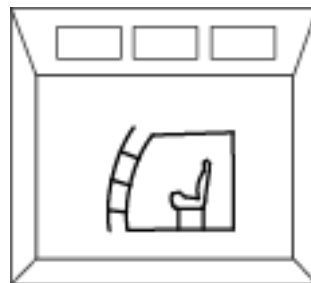

18 Botão

Cabine do operador inclinada para cima pressionado

A luz do meio acende. Incline a cabine para cima.

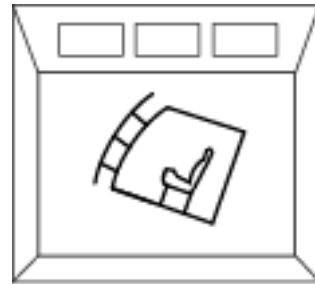

4.1.4 Interruptores e luzes de balancim



Figura 4-4 Interruptores e luzes de balancim

Pos.	Descrição	Pos.	Descrição
1	Luz de advertência de falha de aquecedor de cabine	5	Botão Luz marcadora de canto
2	Luz de controle Fonte de alimentação de superestrutura	6	Botão Sistema limpador de lavador de janela de teto
3	Botão de modo ECO	7	Botão Sistema lavador de para-brisas dianteiro
4	Botão de luzes de trabalho	8	Botão Limpador de para-brisas dianteiro

1 Luz de advertência de falha de aquecedor de cabine acende:

Aquecedor de cabine falha. É sugerido parar o aquecedor de cabine e retificá-lo.

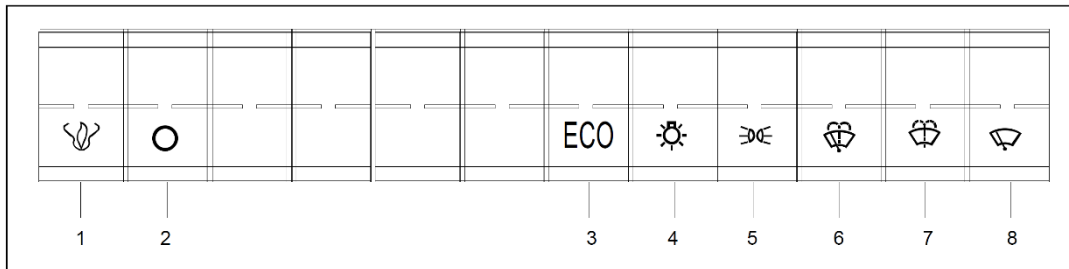
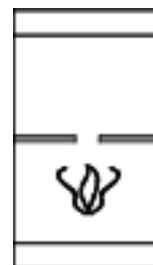



2. Luz de controle

Fonte de alimentação de superestrutura acende:

Após o botão “fonte de alimentação de superestrutura” ser pressionado.



3. Botão de modo ECO

- 1) **OFF:** O sistema ECO não funciona e o ícone “” no monitor LMI fica vermelho. Nesse momento, o acelerador de superestrutura é ativado. E a velocidade do motor depende do acelerador.
- 2) **Posição 1:** O sistema ECO funciona em modo econômico de combustível e o ícone “” no monitor LMI fica verde. Nesse momento, o acelerador de superestrutura é ativado. Porém, a velocidade do motor depende da carga do sistema.
- 3) **Posição 2:** O sistema ECO funciona em modo econômico “” no monitor LMI fica amarelo. Nesse momento, o acelerador de superestrutura é desativado. E a velocidade do motor muda automaticamente com a carga do sistema.
- 4) Durante a telescopagem automática, o botão ECO é desativado sempre que estiver ativado.

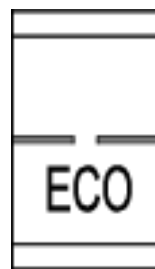

4 Botão de luzes de trabalho na posição 1:

Liga iluminação de fundo.

Posição 2:

Liga a iluminação de fundo, luzes de

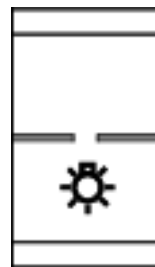

trabalho na cabine do operador, tabela de giro, guinchos e lança.

5 Botão

Luz marcadora de canto

pressionado:

Luz marcadora de canto e luz de lança acendem.

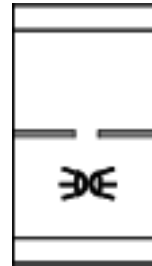

6 Botão

Sistema limpador de lavador de janela de teto

Posição 1:

Limpador de vidro de teto opera.

Posição 2:

Sistema de lavador de janela de teto.

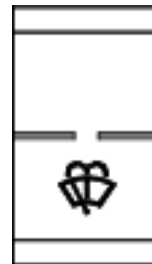

7 Botão

Sistema lavador de para-brisas dianteiro pressionado:

Sistema lavador de para-brisas dianteiro funciona.

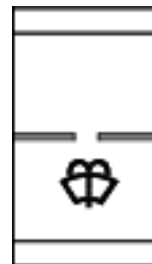

8 Botão

Limpador de para-brisas dianteiro

Posição 1: Velocidade baixa

Posição 2: Velocidade alta



4.1.5 Caixas de controle

4.1.5.1 Caixa de controle esquerda

Para a caixa de controle esquerda, consulte a figura 4-5.



Figura 4 -5 Caixa de controle esquerda

Para o joystick esquerdo e sua ilustração de operação, consulte a figura 4-6.

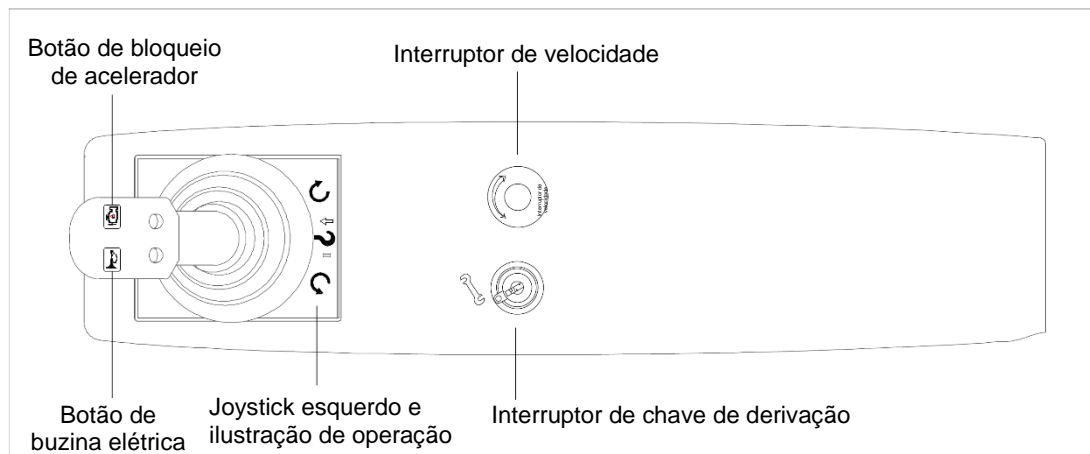

Figura 4-6 Joystick esquerdo e ilustração de operação

Para o painel de controle elétrico esquerdo, consulte a figura 4-7.

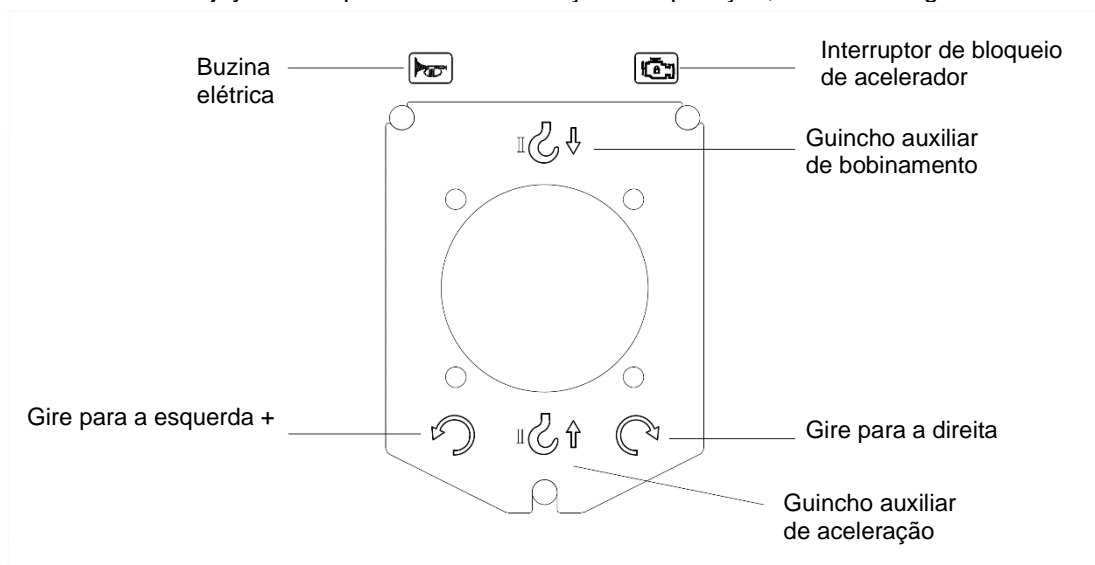

Figura 4 -7 Painel de controle elétrico esquerdo

1 Interruptor de chave de derivação

Quando esse interruptor for ligado, “modo de manutenção” é exibido na tela do limitador de momento de carga. É utilizado para remover a limitação dos movimentos do guindaste nas condições a seguir:

- Sobrecarga
- Superenrolamento
- Rebaixamento excessivo
- Um sensor com falha no sistema de limitador de momento de carga.

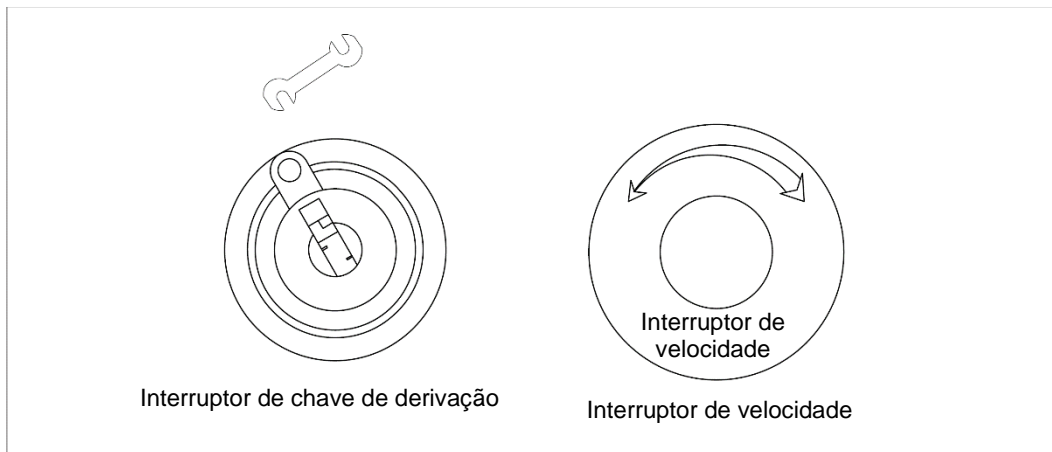
Gire esse interruptor no sentido horário para ativar o modo de manutenção do guindaste e remover temporariamente a limitação mencionada acima.

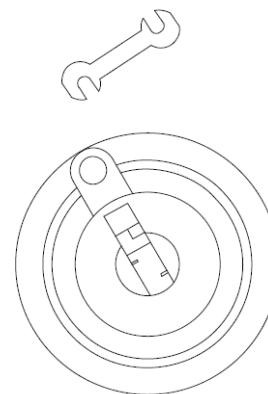

Esse interruptor é desenvolvido para uso apenas em depuração, manutenção ou retificação de falha do limitador

de momento de carga. É estritamente proibido utilizar esse interruptor durante a operação de rotina de guindaste, de modo a evitar ferimentos ou perda de propriedade.

2 Interruptor de velocidade

Quando o interruptor de modo de avanço for pressionado, gire esse interruptor para realizar ajuste contínuo de velocidade de giro, bobinamento/aceleração do guincho principal e auxiliar.

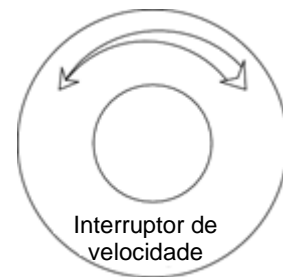

4.1.5.2 Caixa de controle direita

Para a caixa de controle direita, consulte a figura 4-8.



Figura 4-8 Caixa de controle direita

Para o joystick direito e sua ilustração de operação, consulte a figura 4-9.

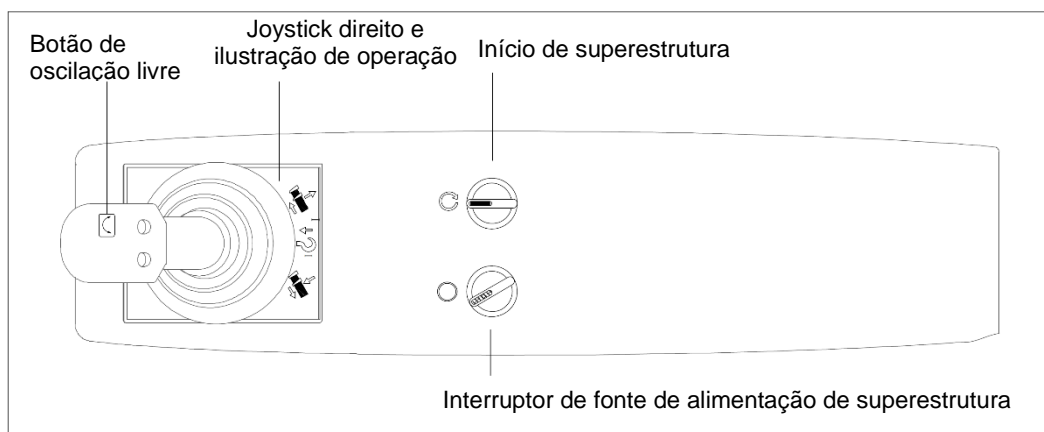

Figura 4-9 Joystick direito e sua ilustração de operação

O joystick esquerdo tem um botão de bloqueio de acelerador. Pressione primeiro o pedal do acelerador para qualquer velocidade e pressione esse botão uma vez para bloquear o acelerador atual e depois pressione esse botão duas vezes para desbloquear o acelerador.

O joystick direito tem um botão de oscilação livre. A mesa de giro pode girar livremente quando o botão de oscilação livre for ativado.

O botão homem morto esquerdo/direito está localizado na parte traseira do joystick esquerdo/direito. Aperte e segure o botão homem morto para operar as funções dos joysticks esquerdo/direito. Se não apertar e segurar esse botão ou ativar o botão homem morto no teclado, os comandos do joystick esquerdo ou direito não podem operar. Consulte a figura 4-10.

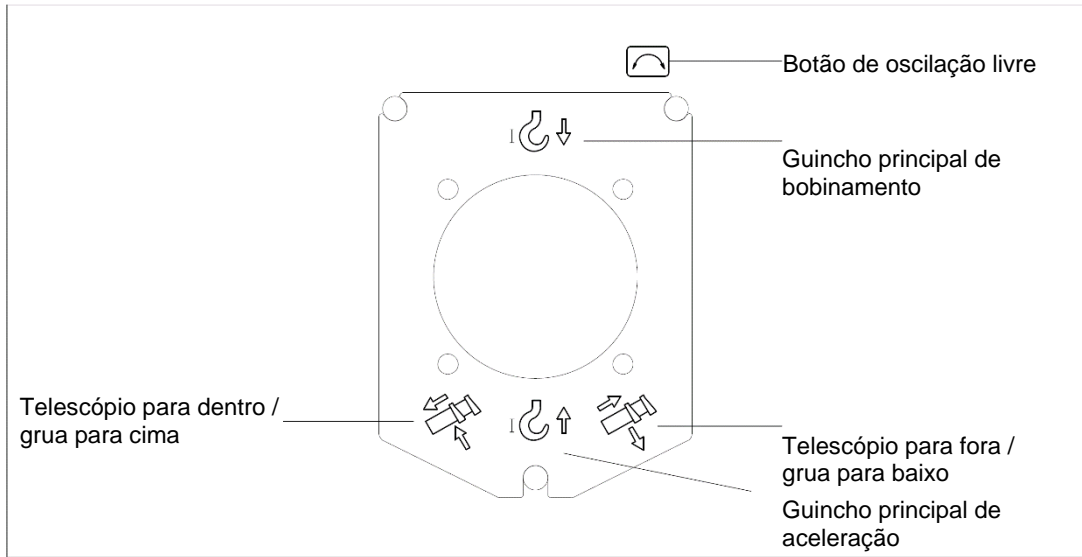

Figura 4-10 Joysticks



Não desative o botão de oscilação livre quando o guindaste for operado com uma carga suspensa. Não empurre e segure o botão homem morto nos joysticks nem ative o botão homem morto no teclado por um longo tempo com ferramentas! Caso contrário, há risco de perdas inestimáveis.

4.1.6 Pedal de controle de motor

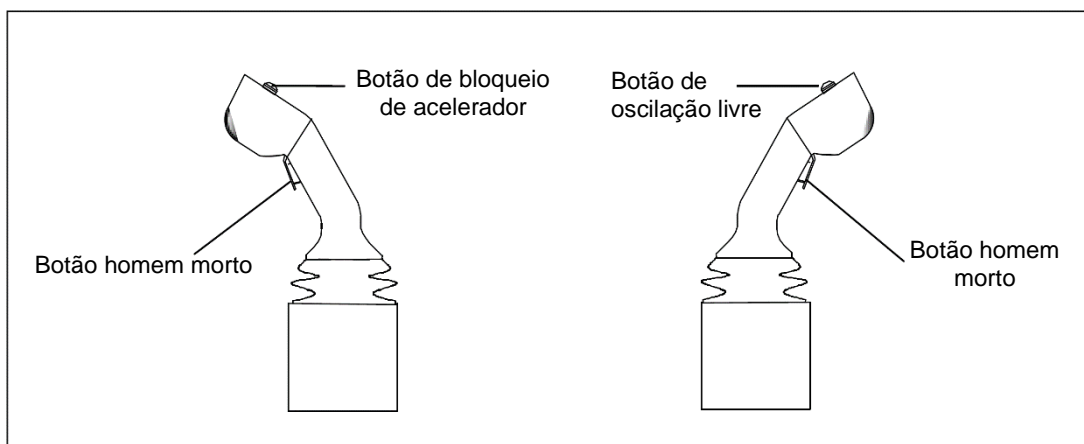
É possível apertar o pedal de controle de motor para aumentar o RPM de motor, para acelerar os movimentos de giro, grua, telescopagem e grua.

4.1.7 Assento do operador

Consulte a figura 4-11.



Figura 4-11 Assento do operador

Pos.	Descrição	Pos.	Descrição
1	Alavanca manual de ajuste do assento superior horizontal	4	Alavanca manual de ajuste do assento inferior horizontal
2	Alavanca manual de ajuste de ângulo do estofado do assento (seção traseira)	5	Alavanca manual de ajuste de ângulo do encosto
3	Alavanca manual, de ajuste de ângulo do estofado do assento (seção dianteira)		

Alavanca manual de ajuste do assento superior horizontal:

Ao ajustar o assento, puxe a alavanca manual para cima para mover o trilho deslizante para adequação com o operador. Após o ajuste de assento ser feito, libere a alavanca manual para travar o trilho deslizante.

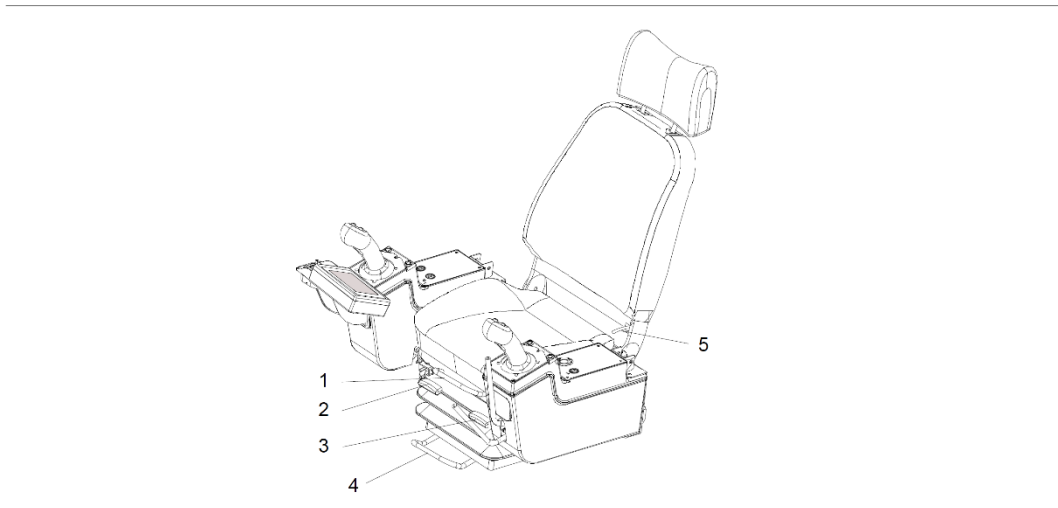
Alavanca manual de ajuste de ângulo do estofado do assento (seção traseira):

Ao ajustar o ângulo do estofado do assento (seção traseira), puxe a alavanca manual para cima para adequação ao operador. Após o ajuste ser feito, libere a alavanca manual para travar o assento.

Alavanca manual, de ajuste de ângulo do estofado do assento (seção dianteira):

Ao ajustar o ângulo do estofado do assento (seção dianteira), puxe a alavanca manual para cima para adequação ao operador. Após o ajuste ser feito, libere a alavanca manual para travar o assento.

Alavanca manual de ajuste do assento inferior horizontal:

Ao ajustar o assento/caixa de controle, puxe a alavanca manual para cima para mover o trilho deslizante para adequação com o operador. Após o ajuste de assento ser feito, libere a alavanca manual para travar o trilho deslizante.

Alavanca manual de ajuste de ângulo do encosto:

Ao ajustar o ângulo do encosto, puxe a alavanca manual para cima para adequação ao operador. Após o ajuste ser feito, libere a alavanca manual para travar o assento.

4.1.8 Pedal de controle de motor

É possível apertar o pedal de controle de motor para aumentar o RPM de motor, para acelerar os movimentos de giro, grua, telescopagem e grua. Quando o sistema ECO funciona em modo econômico, o pedal do acelerador é inválido.

4.2 Sistema de computador

4.2.1 Geral

O limitador de momento de carga é um sistema de computador para controlar e monitorar guindastes móveis. Além de controlar telescopagem de lança via programas de computador, também é de função de autodiagnóstico.

O limitador de momento de carga calcula os dados dos sensores de pressão, sensor de comprimento, o sensor de ângulo e outros dispositivos de monitoramento, para julgar se o guindaste está em condições seguras de trabalho e exibe os parâmetros básicos, como comprimento de lança, ângulo de lança, raio de trabalho, capacidade de levantamento nominal, etc., no monitor.

O ícone “advertência avançada” aparece e a cigarra envia advertência acústica lenta, se a carga atual excede o limite programado (90%) para advertência avançada. Nesse momento, o operador deve prestar muita atenção à operação.

O ícone “parar” aparece, a cigarra envia advertência acústica rápida e todos os movimentos perigosos de guindaste são desligados se a carga atual excede a marcação de 100%.

O guindaste pode operar apenas em direções seguras até a operação segura ser desativada. O limitador de momento de carga pode impedir que o guindaste descarregue ou seja destruído, garantindo dessa forma a operação segura do guindaste. Entretanto, não confie totalmente no limitador de momento de carga. Se a carga de levantamento nominal no limitador de momento de carga for diferente da mostra na tabela de capacidade de levantamento, consulte a tabela de capacidade de levantamento.

Para a tela principal do limitador de momento de carga, consulte a figura 4-12. Para os elementos da tela principal, consulte a tabela a seguir.



Figura 4-12 Tabela principal

Pos.	Descrição	Pos.	Descrição	Pos.	Descrição
1	Carga real (ACT) Carga nominal (MAX)	2	Código de modo de operação	3	Fator de passagem
4	Comprimento de braço	5	Contrapeso	6	Proporção de carga
7	Status de envio estabilizador	8	Status de 5ª. retranca	9	Combinação de telescopagem de seção de lança atual
10	de rolagem de aviso de texto	11	Ângulo de inclinação horizontal	12	Nível de velocidade de vento
13	Comprimento de lança principal	14	Ângulo de lança principal	15	Raio de trabalho
16	Altura de levantamento	17	Indicação de área de trabalho dianteira ou traseira	18	Área de exibição relacionada de controle

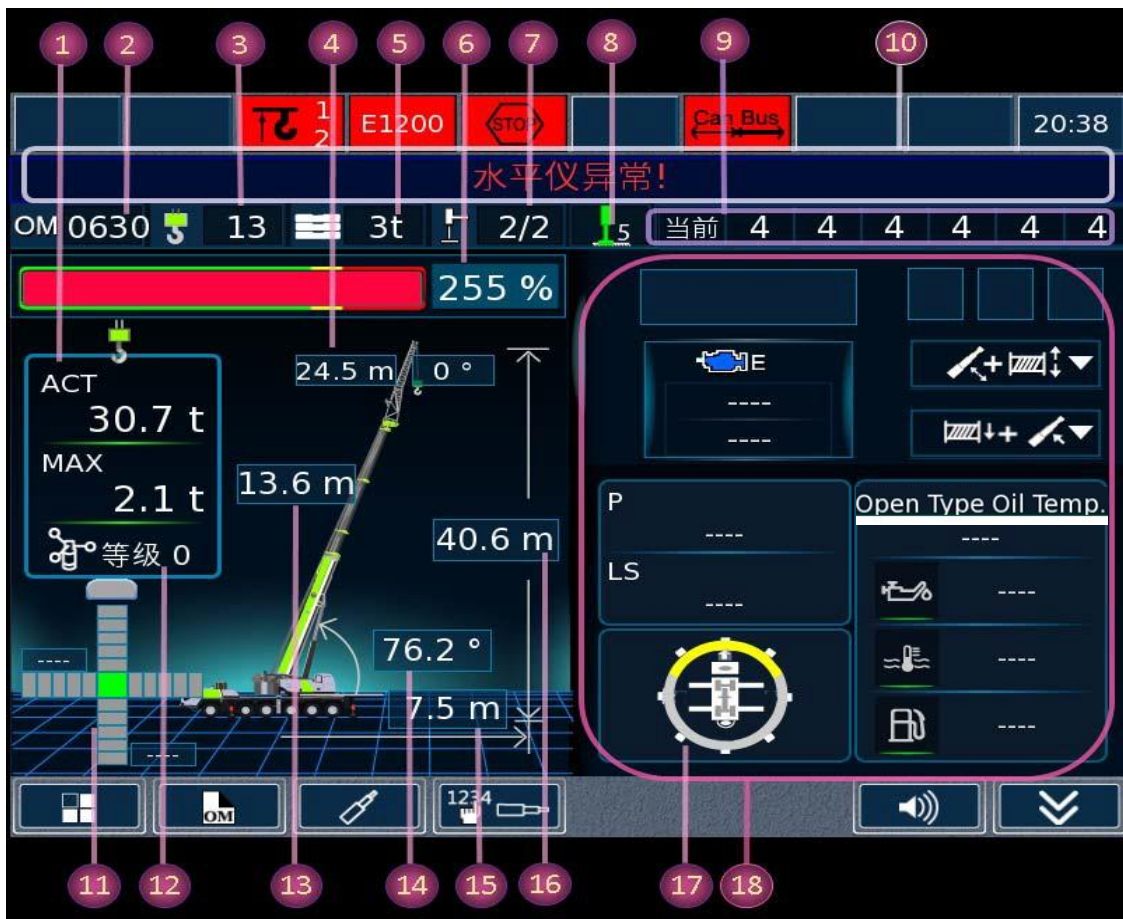

As ilustrações de monitor neste capítulo são apenas exemplos. Os valores numéricos nos ícones e tabelas individuais não correspondem necessariamente de modo exato ao guindaste.

4.2.2 Programas

4.2.2.1 Ligar o sistema de computador e executar autoteste

Após o sistema de computador ser ligado, o limitador de momento de carga executa um autoteste para examinar se os três controladores PLC e seus respectivos nós de mentor estão online. Se nenhum erro for encontrado durante o teste de sistema, o monitor exibe a tela a seguir (consulte a figura 4-13). Logo em seguida, a tela, como mostrada na figura 4-14, aparece no monitor.

Para a tela “aprovado em autoteste”, consulte a figura 4-13.



Figura 4-13 Aprovado em autoteste

Para a tela “seleção de OM”, consulte a figura 4-14.

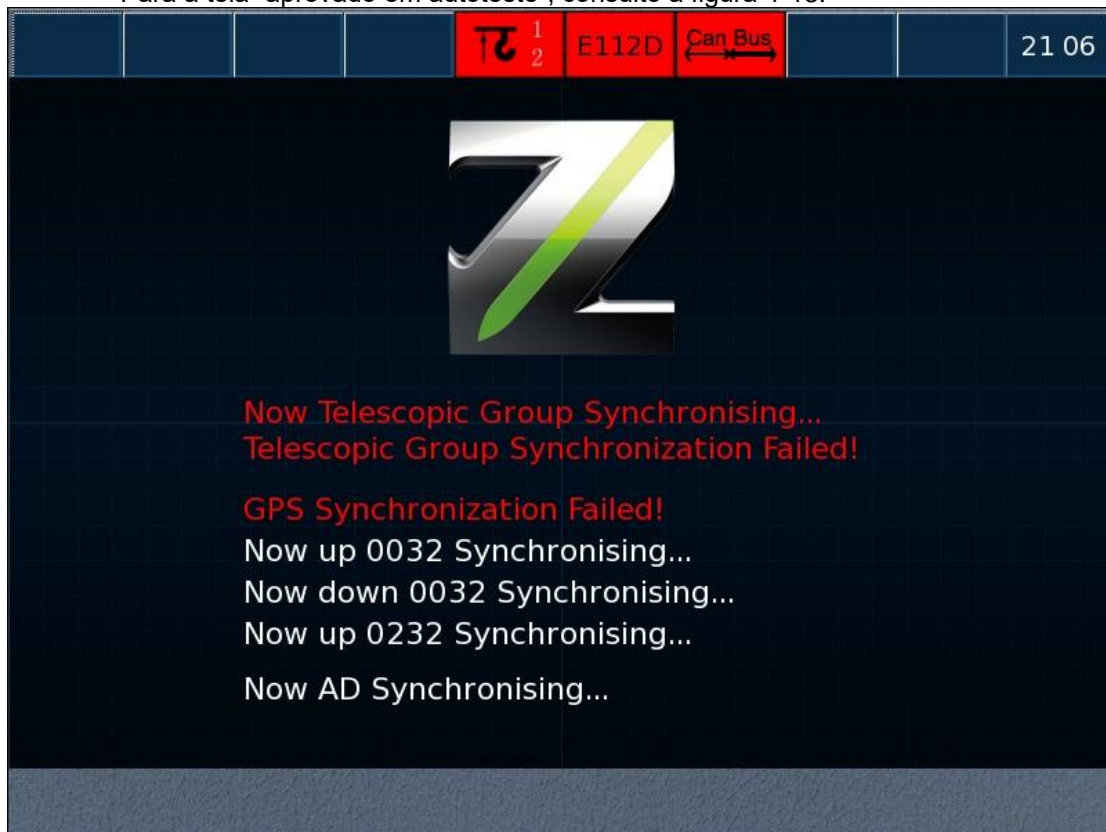

Figura 4-14 Seleção de OM

Se um erro de conexão for encontrado durante o teste, o controlador correspondente não pode passar no teste e o monitor mostra a tela a seguir (consulte a figura 4-15).

Diagnóstico e solução de problemas:

Se uma mensagem de erro aparecer no monitor:

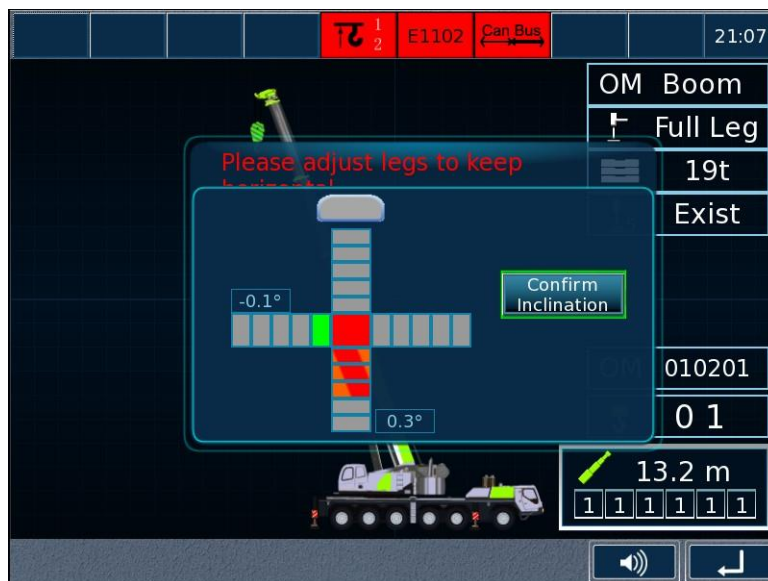
- Desligue o monitor e retifique os erros.
- Comece a executar o autoteste novamente.

Se um texto lembrando “ajuste o nivelamento do quadro do chassi” aparecer na tela de confirmação de OM, ajuste os estabilizadores para obter o nivelamento de acordo com a seção 4.5.2: *Estabilizadores*.



Se um erro for encontrado durante a comunicação, a cigarra não para de enviar o alarme após ligar o computador. É um fenômeno normal. Retifique a falha de comunicação.

Para a tela “reprovado em autoteste”, consulte a figura 4-15.



Figura 4-15 Reprovado em autoteste

4.2.2.2 Tela principal – programa de configuração

Após OM ser selecionado, ele alterna automaticamente para a tela principal - programa de configuração (consulte a figura 4-16). Diversos parâmetros podem ser monitorados dessa tela em tempo real.

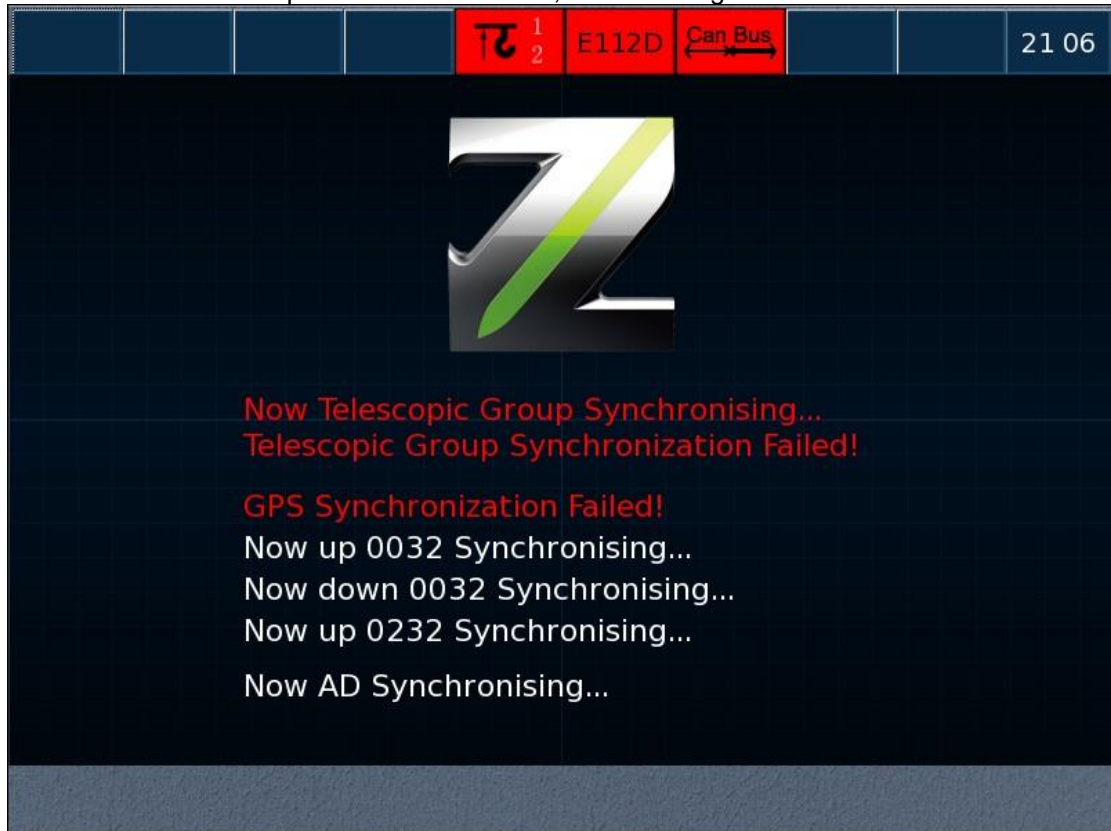

Pos.	Descrição	Pos.	Descrição	Pos.	Descrição
1	Ícones de alarme	2	Rolagem por textos de alarme	3	Código de modo de operação
4	Proporção de carga	5	Status de carga suspensa	6	Interruptores de motor e funcionais
7	Indicações de instrumento e pressão	8	Teclas de função		

Figura 4-16 Tela principal - programa de configuração

As funções dos elementos operacionais de monitoramento individual dependem do programa e podem ser diferentes em qualquer programa de execução. Portanto, a descrição dos programas individuais deve ser descrita em detalhes.

a) Linha de tecla de função

A linha de tecla de função consiste de teclas de função F1 a F8 e linha de ícones de tecla de função acima dela. (Consulte a figura 4-17.)

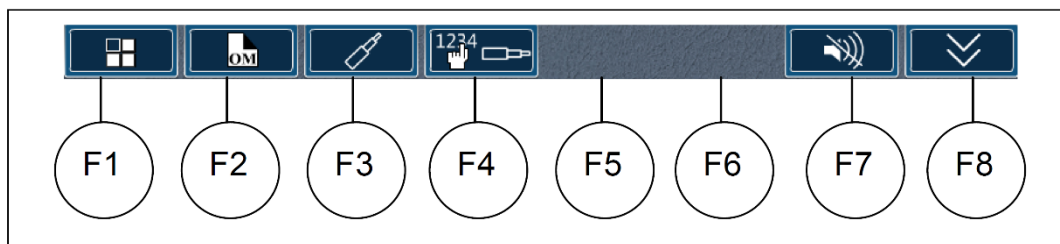

Figure 4-17 Linha de tecla de função

Teclas de função na parte inferior da interface de monitoramento:

F1: vá até a interface de lista funcional (ou interface de navegação) para inserir páginas funcionais de subnível.

F2: vá até a interface de definição de modo de operação.

F3: vá até a interface de telescopagem automática/manual. F4: vá até a interface de seleção de seção de lança telescópica. F7:

comute o interruptor de cigarra.

F8: virada de página de instrumentos e indicação de pressão.



Durante as condições a seguir, pressione F7 para silenciar a cigarra, porém a falha não pode ser eliminada.

- **Rebaixamento excessivo;**
- **Superenrolamento;**
- **Sobrecarga;**

- Nível de óleo hidráulico muito baixo
- Pressão de passagem central muito alta.

O operador deve retificar o falha de acordo com o sistema, lembrando da condição real.

A falha que aciona a cigarra está localizada em: F5: Consulta de falha – F5: Consulta de parâmetro de movimento – F4: Luzes indicadoras de movimento.

Pressione a tecla F1 na interface principal para entrar na interface de navegação. Consulte a figura 4-18.



Figura 4-18 Interface de navegação

Clique nos ícones correspondentes na interface principal para entrar nas subinterfaces relacionadas. O menu da subinterface é como segue:

- Definição de parâmetro: após inserir uma senha correta, é possível modificar os parâmetros de controle de PLC. (é sugerido modificar esse parâmetros de acordo com as instruções de especialistas. Caso contrário, o veículo pode quebrar. E há risco de acidentes!)
- Monitoramento de comunicação: monitore o estado da rede CAN do veículo completo.
- Consulta de falha: Incluindo falhas de limitador de momento de carga, motor, controladores, válvulas de interruptores e sensores.
- Interface de calibração: incluindo sensor de deslocamento, CR2012, codificador, codificador de guincho principal, sensor de quantidade de óleo e anemômetro. (Este veículo não tem codificador de giro, codificador de guincho principal, sensor de quantidade de óleo e calibração de comprimento de cilindro de contrapeso).
- Monitoramento de movimento: incluindo movimento de guindaste “giro”, “grua” e “telescópio”, movimentos de contrapesos e cabine do operador, E/S de pino de lança e movimentos de pino de cilindro e consulta de monitoramento de estado.

- f) Interface GPS: incluindo entrada de GPS, ON, monitoramento de estado, consulta de falha de GPS, desbloqueio de emergência, GPS OFF, ativação GPS, etc.
- g) Definição de sistema: incluindo data e hora, brilho de monitor, monitor de caracteres chineses e orientais e função de definição de sistemas em caracteres ocidentais.
- h) Definição de OM: definir OMs.
- i) Manutenção: verifique a data e intervalo de manutenção.
- j) Função de consulta: incluindo porta E/S, valor AD e valores calculados de limitador de momento de carga.
- k) Ferramenta de depuração: depuração de referência antes da entrega e depuração de convenção, limite apenas para o pessoal profissional.

**CUIDADO**

Quando os itens abaixo ocorrer, a cigarra envia advertência acústica rápida.

- **O guincho principal ou auxiliar está no modo de aceleração e o bloco de gancho toca no peso de interruptor de limite de grua.**
- **O sensor identifica que o guincho principal tem 3 enrolamentos de cabo de arame nele.**
- **O sensor identifica que o peso de carga é superior ao peso da carga no sistema**

Pressione a tecla F7 (ícone de cigarra) para desligar a cigarra. Porém, a falha atual não pode ser removida. O operador pode remover manualmente a falha de acordo com as condições reais.

b) Status de lança

Exibe o comprimento de lança principal, ângulo, raio e nivelamento de quadro de chassi.

O nivelamento de quadro de chassi é utilizado para indicar o ângulo de inclinação em tempo real do quadro de chassi durante a operação de levantamento.

Se o braço for selecionado, também vai mostrar a configuração do braço. Consulte a figura 4-19.



Figura 4-19 Status de lança

Pos.	Descrição	Pos.	Descrição	Pos.	Descrição
1	Peso de carga real	2	Capacidade máxima de levantamento	3	Velocidade de vento atual
4	Comprimento de braço	5	Deslocamento de braço	6	Comprimento de lança principal
7	Altura de levantamento	8	Ângulo de lança	9	Raio de trabalho

A figura 4-19 exibe o comprimento de lança, ângulo de lança e nivelamento de quadro de chassi, etc.

O nivelamento de quadro de chassi pode ser utilizado para observar o ângulo de inclinação em tempo real do quadro de chassi durante as operações de levantamento.

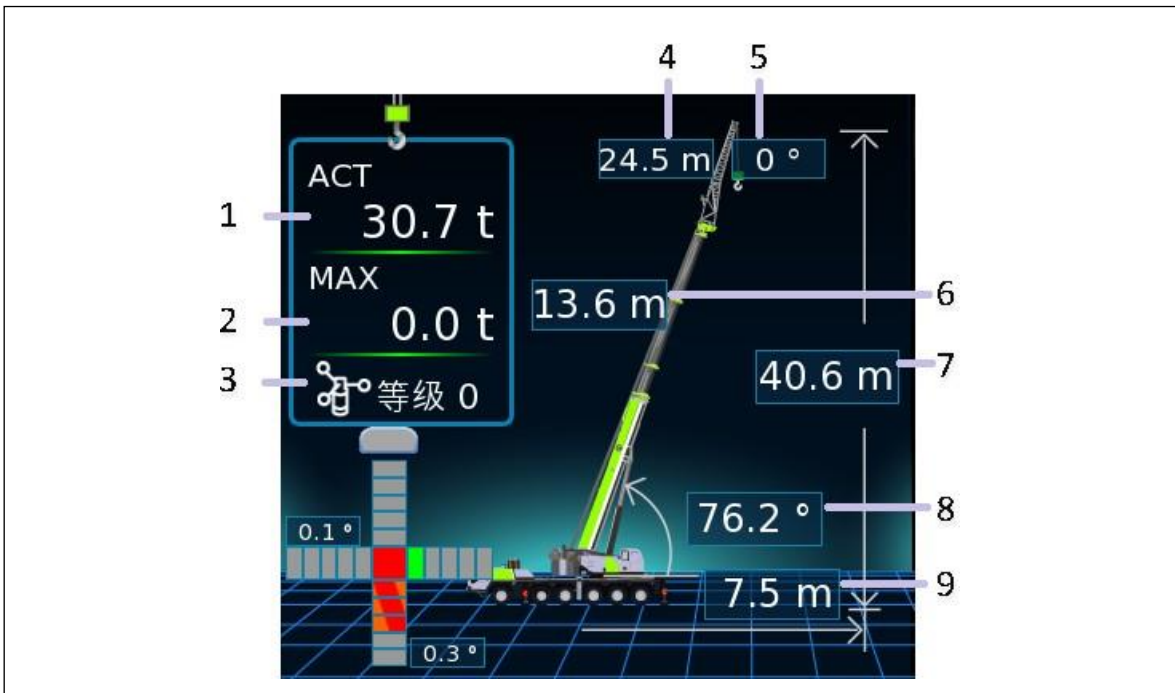
Quando o braço for utilizado, um ícone de braço também aparece. Código OM, contrapeso, passagem, ângulo de inclinação de guindaste em tempo real e status estabilizadores, etc. são exibidos, consulte a figura 4-20.



Figura 4-20 Monitor OM

Pos.	Descrição	Pos.	Descrição	Pos.	Descrição
1	Código de modo de operação	2	Fator de passagem	3	Contrapeso
4	Retranca estendida totalmente/pela metade	5	5ª. retranca estendida	6	Código de seção de lança telescópica

Para instrumentos e indicações de pressão, consulte a figura 4-21. (pressionar a tecla F8 pode alternar entre essas duas interfaces).

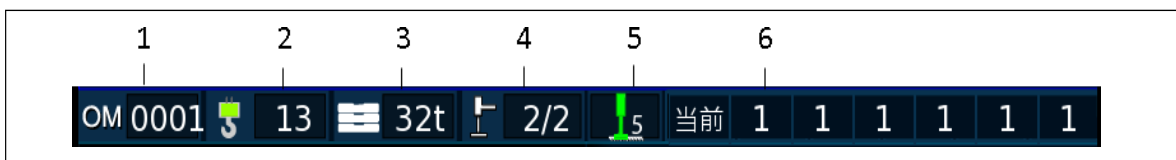

Figura 4-21 Interface de indicação de instrumento

Pos.	Descrição	Pos.	Descrição
1	Pressão na porta P	6	Monitor de área dianteira e traseira
2	Temperatura de óleo hidráulico, sistema aberto	7	Reserva de combustível
3	Pressão na porta L	8	Comprimento e velocidade de cabo de guincho principal
4	Pressão do óleo do motor	9	Tensão de alimentação

5	Temperatura de fluido refrigerante		
---	------------------------------------	--	--

Para porcentagem de carga, consulte a figura 4-22.

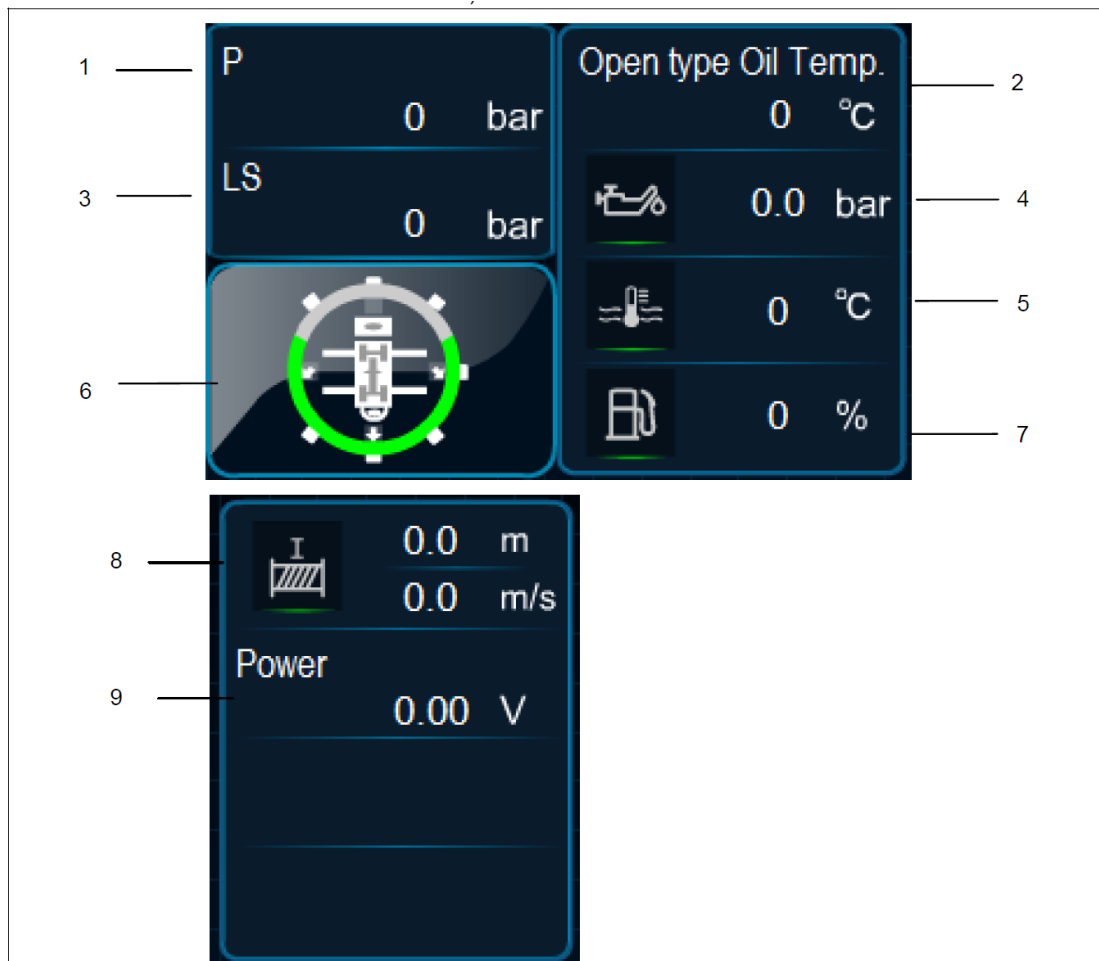

Figura 4-22 Monitor de porcentagem de carga

A figura acima exibe o peso de carga, incluindo exibição de dígitos, gráfico e escala de velocidade de vento.



Figura 4-23 Interruptores de velocidades e função

Pos.	Descrição	Pos.	Descrição
1	Mudança de velocidade (alta/média/baixa) ou proporção de velocidade contínua	2	Pedal acelerador e status de bloqueio de guindaste
3	Velocidade do motor	4	Horas de operação do motor
5	Modo ECO, modo LMI, filtro de óleo de retorno entupido	6	Interruptor de função de compensação de desvio
7	Interruptor de movimentação simultânea de giro e guincho		

Posição 1 na figura 4-23 é um interruptor de velocidade. Quando o interruptor “pré-seleção de velocidade baixa/média/alta” for colocado nessas três velocidades respectivamente, esse interruptor vai exibir os ícones a seguir, como coelho, tartaruga e lesma.



Quando o botão de modo de avanço no painel de interruptor for pressionado, a posição 1 na figura 4-23 vai exibir o valor de velocidade atual como a figura 4-24 mostrada. Ative o interruptor de velocidade na caixa de controle esquerda para regular a velocidade de 20% - 100%. E, portanto, os movimentos de guindaste “grua” e “giro” pode realizar ajuste de velocidade contínua.



Figura 4-24 Monitor de velocidade

Para combinação de telescopagem de lança, consulte a figura 4-25. A combinação indica a telescopagem de lança atual.



Figura 4-25 Exibição de combinação de telescopagem de lança

Para indicadores principais, consulte a figura 4-26.

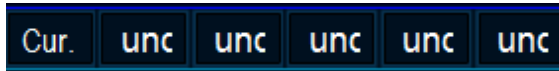

Figura 4-26 Indicadores principais

Pos.	Descrição	Pos.	Descrição
1	Luz de advertência de baixa tensão	6	Luz de advertência Advertência antecipada/advertência de sobrevelocidade de vento
2	Luz de controle Caixa de controle remoto de contrapeso/controlador remoto	7	Luz de advertência de falha de barramento CAN
3	Luz de advertência Interruptor de limite de grua / interruptor de limite de abaixamento	8	Luz de controle Código de erro de GPS
4	Luz de controle Código de erro de limitador de momento de carga	9	Luz de advertência Sobreprensão de 5ª. retranca
5	Luz de advertência Advertência antecipada/advertência de sobrecarga	10	Exibição de hora atual

4.2.2.3 Definição de OM

Defina OMs e combinação de telescopagem de lança antes da telescopagem.
 Pressione a tecla F2 na parte inferior esquerda da interface principal ou reinicie o limitador de momento de carga para entrar na interface de seleção

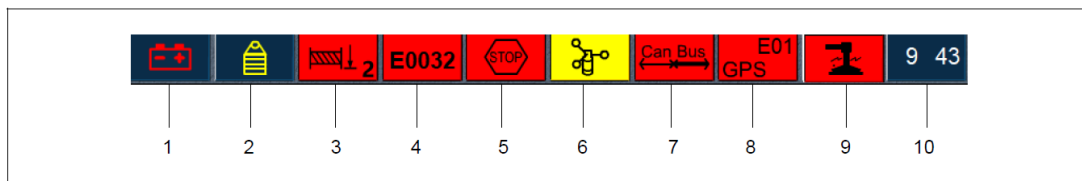
de OM. Consulte a figura 4-27.



Figura 4-27 Interface de seleção de OM

O ângulo de inclinação horizontal do quadro de chassi deve ser ajustado para estar entre 0,3 graus (verde) antes de operações de guindaste. Após uma operação de levantamento iniciar, o medidor de nível é utilizado apenas para lembrete de segurança e o nivelamento não deve ser ajustado indiscriminadamente.





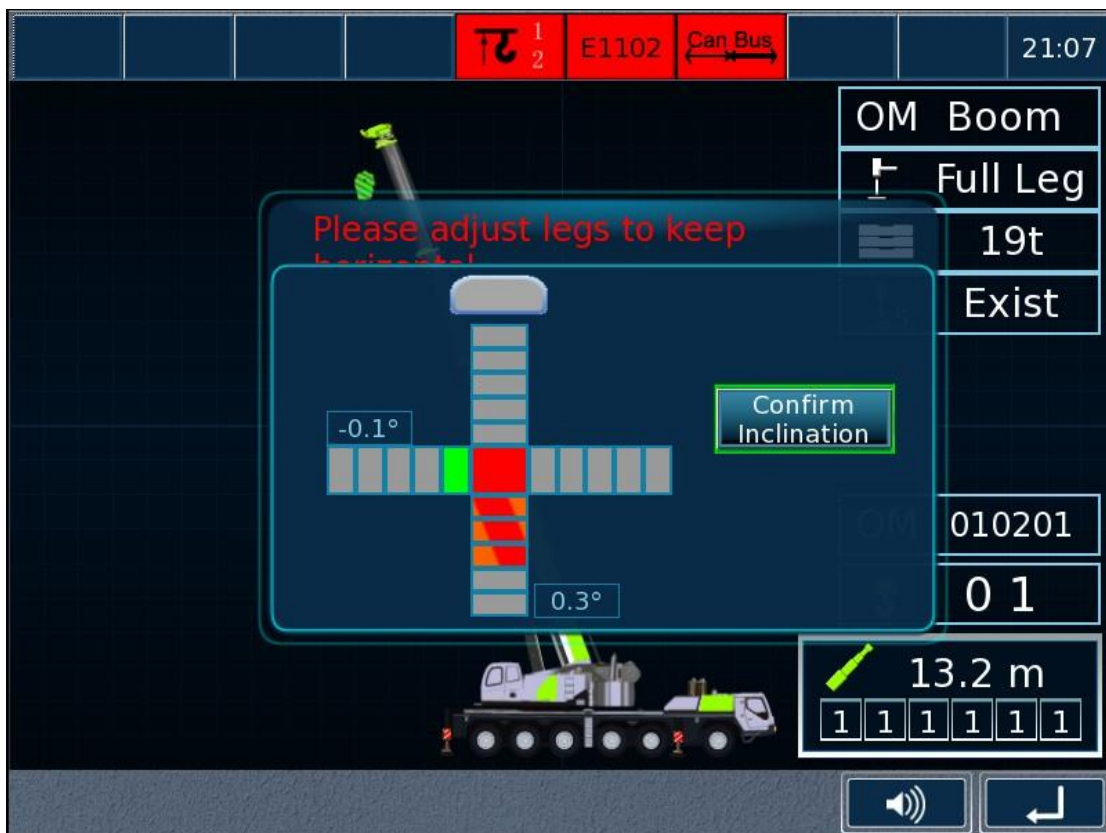

Pressione  na interface de seleção de OM para entrar na interface de seleção de OM principal. Consulte a figura 4-28.



Figura 4-28 Interface de seleção de OM principal

Pressione  para rolar pelos itens na página principal. Pressione  para entrar na página de itens. Quanto todos os parâmetros de certos modos operacionais forem selecionados, pressione  para salvar o modo operacional real. Pressione  para sair da definição atual e voltar para a página principal.

Pressione  na interface de modo de operação para selecionar um fator de passagem, como mostrado na figura 4-29.







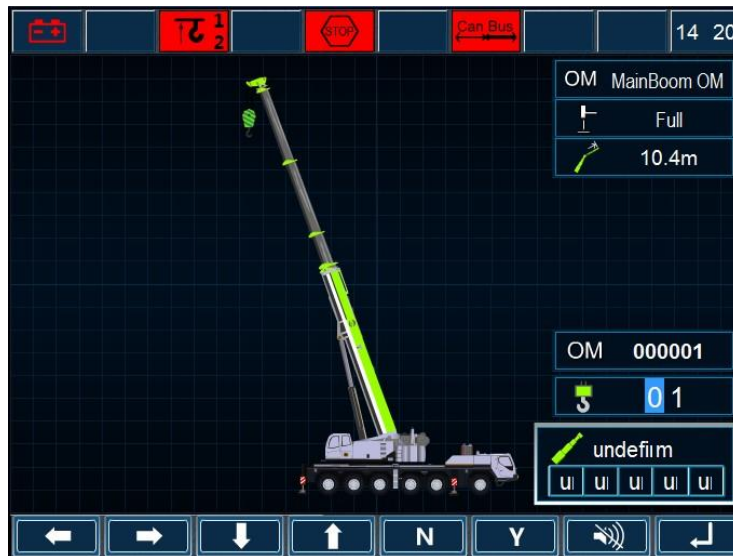

Figura 4-29 Interface de seleção de passagem de gancho

Pressione  e  para comutar entre mudança de número e o primeiro e segundo dígitos.

Pressione  ou  para aumentar ou diminuir o número de fator de passagem.

Pressione  para salvar a definição atual.

Nota:

Lembre-se de pressionar  para salvar a definição atual!
Se a definição atual estiver incorreta, pressione “definição de OM” na interface de monitoramento par redefinir os parâmetros.

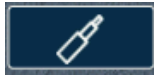

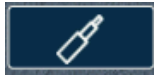
Pressione  na interface OM ou interface principal par entrar na interface de confirmação de lança telescópica, como mostrado na figura 4-30.





Figura 4-30 Interface de confirmação de status de telescópico de lança

O status de seção de lança de telescópico é exibido.

Se o status exibido estiver em conformidade com o status real, pressione  para confirmar o status e entrar na interface de controle de lança telescópica.

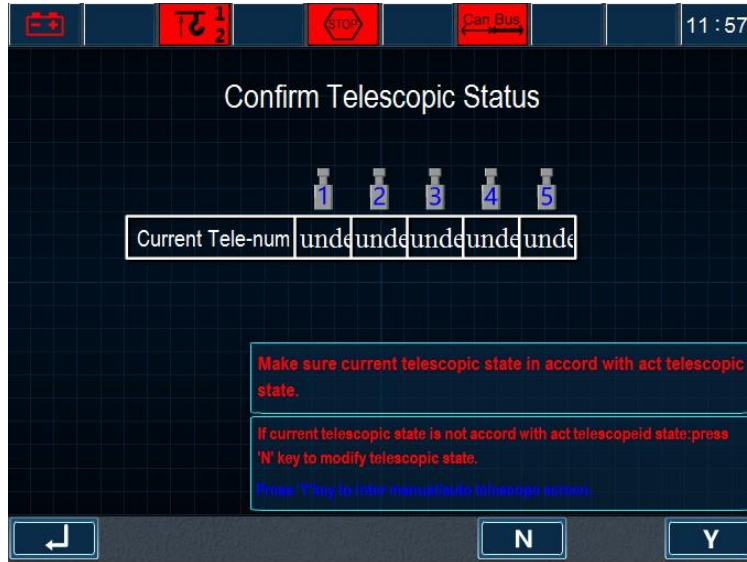

Quando os dois não estiverem em conformidade, pressione  para entrar na interface de edição de seção de lança telescópica, como mostrado na figura 4-31.



Figura 4-31 Interface de edição de seção de lança telescópica

Pressione  para editar combinação de

seção de lança telescópica e pressione  para salvar a combinação

atual, como mostrado na figura 4-32.



Figura 4-32 Interface de edição de seção de lança telescópica



Pressione  na interface de seleção de OM ou interface principal para entrar na interface de seleção de combinação de telescopagem. Consulte a figura 4-30.







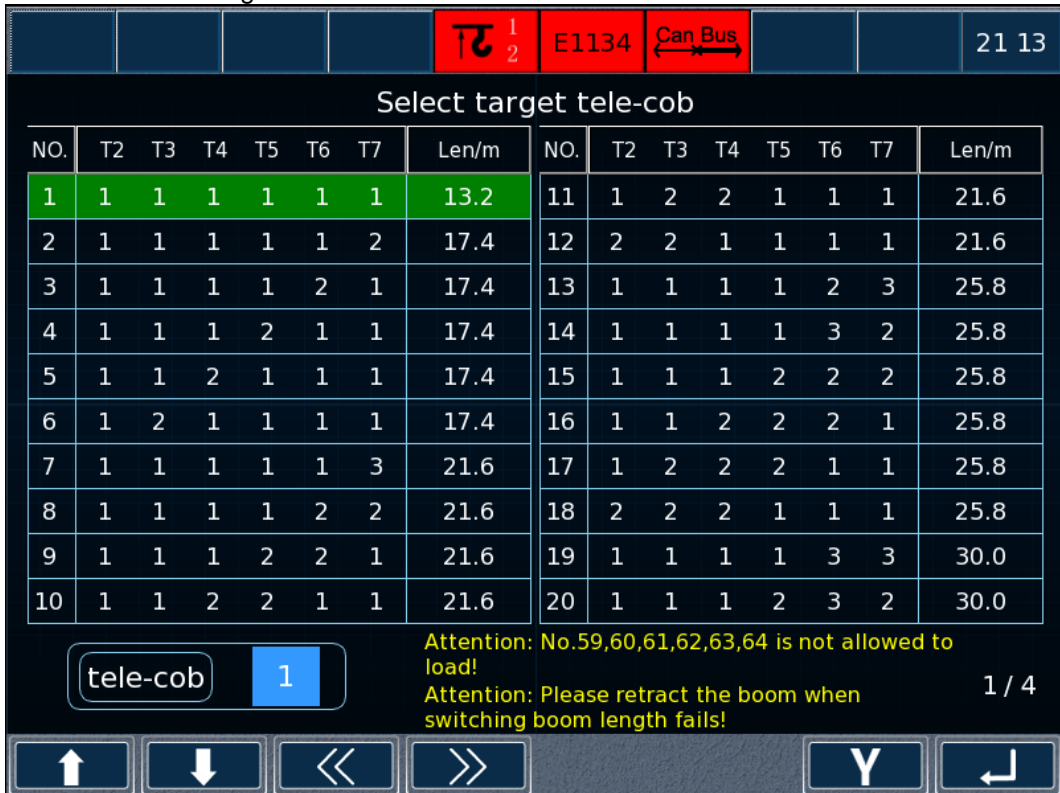

Figura 4-30 Interface de seleção de combinação de telescopagem

Pressione   para comutar entre páginas de tabela;

Pressione   para selecionar a combinação de seção de lança alvo, o número selecionado deve ser exibido na parte esquerda inferior da tela.

Pressione  para salvar a combinação atual.
 Após a combinação alvo ser definida, pressione “autoinicialização” para ativar telescopagem de seção de lança automática.
 Pressione “telescópio manual” para entrar na interface de telescopagem manual.



- (1) Apenas OM selecionado é o legal, o sistema pode realizar a operação de telescopagem.
- (2) Os últimos números em amarelo são OMs que não são para levantar a carga, mas para engraxar a lança. Sob esses OMs, não levante a carga!

4.2.2.4 Operação de telescopagem

Duas operações de telescopagem: manual/automática

A telescopagem automática é fortemente recomendada.

A telescopagem automática pode ser ativada apenas quando a telescopagem automática for inválida.

Ilustração de combinação de lança (consulte a figura 4-34).



Figura 4-34 Combinação de lança

Números “I – VI”: seção telescópica correspondente (número mais alto = seção telescópica mais distante)

Números “1 – 4”: Status de extensão de seção telescópica (em porcentagem %)

1: 0% 2: 46% 3: 92% 4: 100%

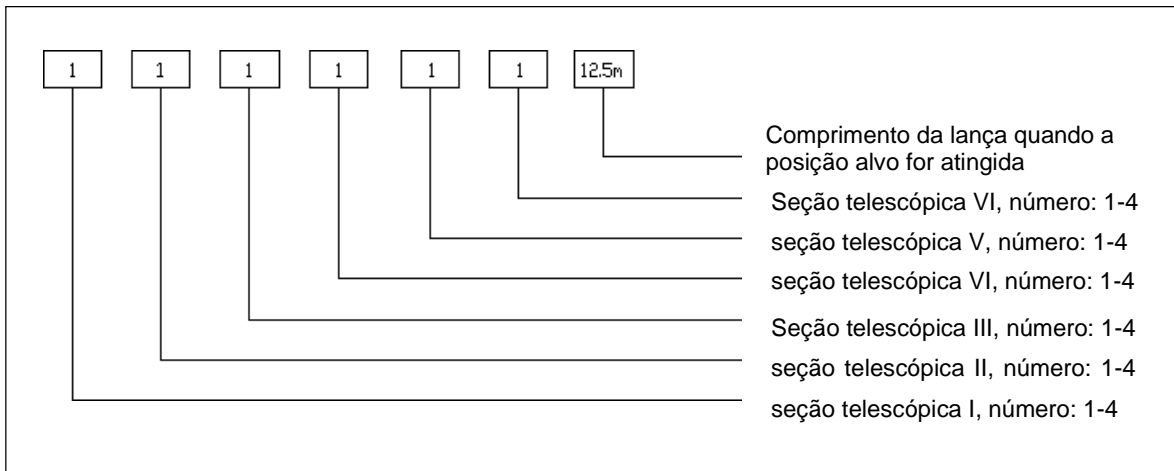
4.2.2.4.1 Telescopagem automática

A telescopagem automática tem 3 passos no total.





Figura 4-35 Telescopagem automática

- a) Consulte a figura 4-35. Verifique se os pré-requisitos a seguir são atendidos:
- 1) O modo operacional válido foi definido.
 - 2) O interruptor de fim de curso de elevação e interruptor de limite abaixamento não são ativados.
 - 3) Comute “pré-seleção de grua/telescópio” como mostrado na figura 4-35, foi definido para “telescópio”.
 - 4) Ative os interruptores “operação de pino de cilindro” e “operação de pino de cilindro”, como mostrado na figura 4-35, para abrir o pino de cilindro e pino de lança.
 - 5) Desative os interruptores “operação de telescopagem automática” e “operação de telescopagem manual”, como mostrado na figura 4-35.
 - 6) Ative o interruptor “pré-seleção de velocidade normal/baixa/extremamente baixa” como na figura 4-35 em velocidade normal.
 - 7) O ícone  não aparece.

! CUIDADO

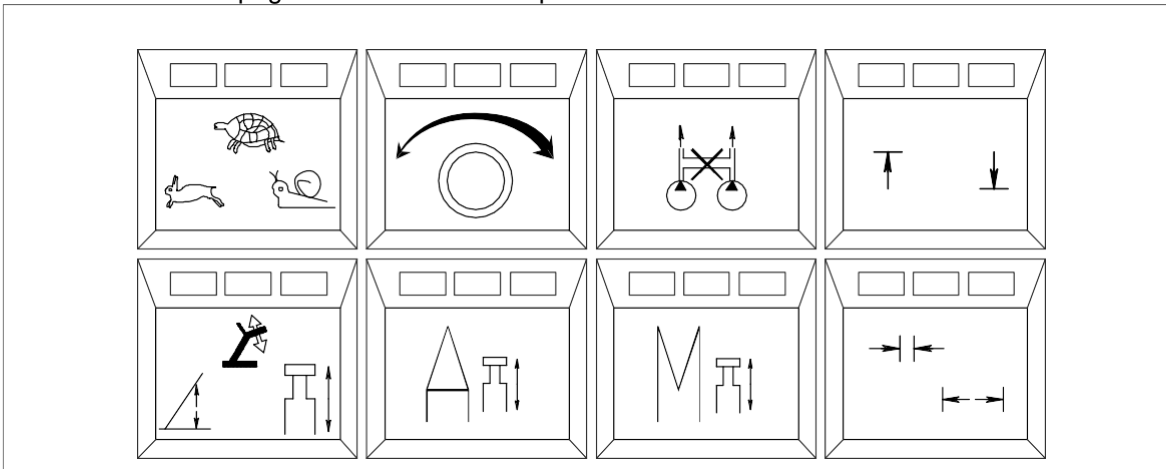
- (1) Se um erro de telescopagem for detectado (o ícone vermelho acima acende), execute telescopagem da lança manualmente até o erro ser removido.
- (2) Todos os pré-requisitos mencionados devem ser atendidos. Caso contrário, a operação de telescopagem automática não pode ser ativada.
- (3) Durante a telescopagem automática, verifique se o ângulo de lança não é inferior a 78,5°. Status de lança

! PERIGO

É muito importante confirmar o status de lança atual!

A definição inadequada resulta em movimento de telescopagem incorreta e causa acidentes fatais!

Área de exibição superior exibe os parâmetros a seguir:

- (1) Comprimento de lança
- (2) Ângulo de lança
- (3) Raio de trabalho
- (4) Velocidade do vento

Exibições de área de exibição principal:

- (1) Ícones de luz de controle
 - (2) Status de lança atual
 - (3) Status de lança alvo
- a) Informações sobre pino de lança, pino de cilindro e outras informações relacionadas.



Figura 4-36 Telescopagem

Ícones de luz de controle: (os ícones no lado superior são correspondentes às luzes de controle no painel de instrumentos)

Consulte a figura 4-37.

Para descrição de ícones de luz de controle, consulte a tabela 4-9.



Figura 4-37 Ícones de luz de controle

Pos.	Descrição	Pos.	Descrição
1	Pino de cilindro esquerdo aberto	4	Lança com pinos retirados
2	Pino de cilindro esquerdo fechado	5	Pino de cilindro direito aberto
3	Lança com pinos inseridos	6	Pino de cilindro direito fechado

b) Iniciar telescopagem automática

Quando “autoinicialização” e ícone de retorno ficarem verdes, isso indica que os pré-requisitos de telescopagem automática foram atendidos. Pressione F6 correspondente a “autoinicialização” E “telescópio manual”, “autoinicialização” e ícones de tecla de retorno ficam cinza.

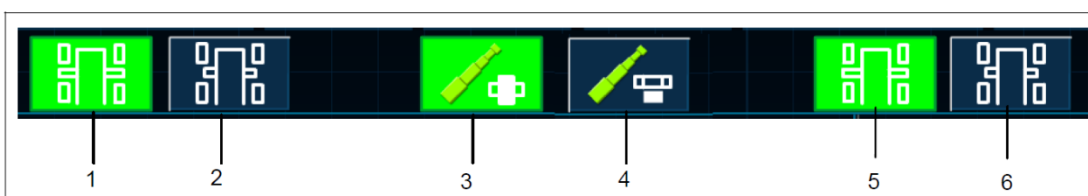
Pressione o interruptor de telescopagem automática no painel de controle (consulte a figura 4-35) para a posição “auto”, isto é, a luz do meio do interruptor acende em vermelho, a telescopagem automática de lança será executada automaticamente, de acordo com a definição do operador.

Quando a lança atingir o comprimento alvo, “retornar” e “telescópio manual” voltam para verde, indicando que a telescopagem está completa.

1) Erro de ativação:

Se um erro for detectado durante a telescopagem, os movimentos de telescopagem vão parar automaticamente e esse ícone “” vai ser destacada em vermelho.

Pressione F3 para comutar para figura 4-38.

O conteúdo destacado em vermelho são as informações detalhadas de erro. Retifique os erros manualmente de acordo com as instruções.



Figura 4-38 Erros de telescópio de lança

2) Modifique o status de lança atual:

Antes de comutar para o status de telescopagem de lança, confirme o status de lança atual (consulte a figura 4-30) primeiro.

Se o status de lança exibido for diferente do real, pressione a tecla de função F6 “N” para comutar para figurar 4-40 para modificação.

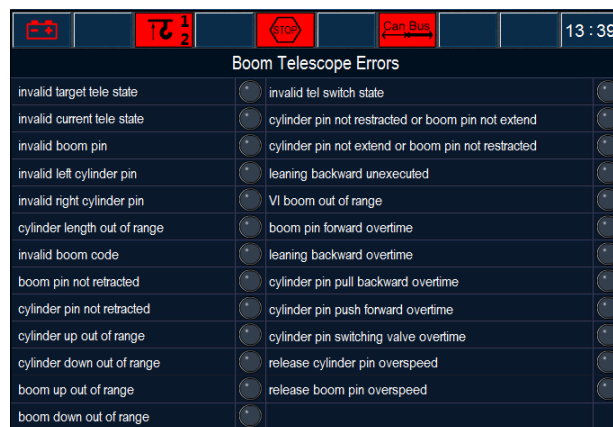

Figura 4-39 Inserir senha



Figura 4-40 Modificação de status de lança atual

Como modificar o status de lança atual (consulte a figura 4-38):

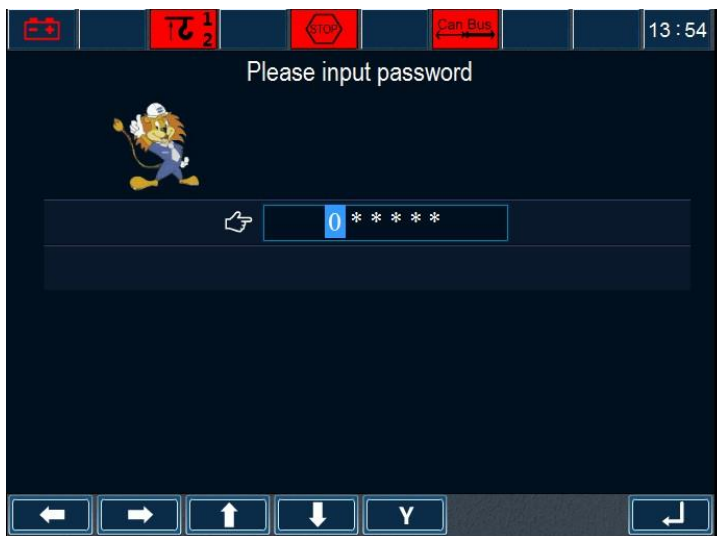
- Pressione as teclas de função F1 e F2 para selecionar a seção telescópica correspondente que precisa ser modificada.
- Pressione as teclas de função F3/F4 para aumentar/diminuir os valores numéricos.
- Pressione a tecla de função F7 "Y" para confirmação.



É muito importante confirmar o status de lança atual. Se o status de lança atual for definido incorretamente, há risco de perigos fatais! Se precisar da senha, entre em contato com nosso técnico.

Telescopagem manual

4.2.2.4.2 Telescopagem manual

CUIDADO

Como a telescopagem manual é complexa, é recomendado iniciar a telescopagem manual apenas quando a telescopagem automática for inválida.

A telescopagem manual tem 6 passos no total.

- a) O modo operacional válido foi definido. Para mais detalhes, consulte as instruções em “telescopagem automática”.
- b) Comutação “pré-seleção de grua/telescópio” foi definida para “telescópio”.
- c) Ative os interruptores “operação de pino de cilindro” e “operação de pino de cilindro” para abrir o pino de cilindro e pino de lança.
- d) Desative os interruptores “operação de telescopagem automática” e “operação de telescopagem manual” (consulte a figura 4-35).

CUIDADO

O ângulo de lança não deve ser inferior a 78,5 graus durante a telescopagem manual, processo de colocação ou retirada de pinos, para garantir a segurança da telescopagem.

- e) Pressione a tecla de função F2 na figura 4-34 para comutar para figura 4-41.
- f) Telescopagem manual de seções de lança.

Na figura 4-41, se os pré-requisitos acima forem atendidos, “início manual” deve ser destacado em verde.

Nesse caso:



- 1) Pressione a tecla de função F6 e “início manual” e  é exibido em cinza.
- 2) Ative o interruptor “operação de telescopagem manual”
- 3) Mova o joystick direito.
- 4) Use pinos de mancal, pinos de trabalho e interruptor de derivação, para telescopagem manual de seções de lança.



Figura 4-41 Status de lança durante telescopagem manual

Pos.	Descrição	Pos.	Descrição
1	Ícones de luz de controle	8	Carga real
2	Código de lança	9	Valor de controle de telescopagem
3	Status atual	10	Comprimento de cilindro 1
4	Status de alvo	11	Comprimento de cilindro atual
5	Seção telescópica alvo	12	Comprimento de cilindro 2
6	Exibição de pressão	13	Velocidade de telescópio
7	Carga nominal		

Pressione  para entrar na interface de manutenção de seção de lança telescópica.

Pressione  para entrar na interface de calibração, em que sensor de deslocamento, posição de zero de lança, velocidade de telescopagem de lança e velocidade de telescopagem de cilindro podem ser calibrados.

Pressione  para iniciar a telescopagem de seção de lança manual.



Observe as instruções a seguir ao realizar a operação de telescopagem manual.

a) Desbloqueie o cilindro de telescopagem



Figura 4-42 Desbloqueio do cilindro de telescopagem



Não desbloqueie o cilindro até o ícone “Lança com pinos inseridos” acender. Caso contrário, risco de danos graves!

b) Bloqueie o cilindro de telescopagem

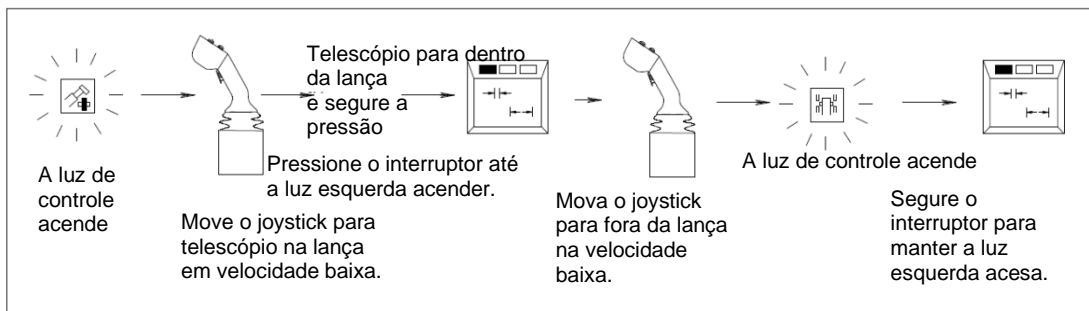
Ao desbloquear o cilindro de telescopagem manualmente, é possível estender o pino do cilindro antecipadamente. Isso significa que, quando o cilindro de telescopagem entra na seção telescópica alvo e luz de controle correspondente “seção telescópica alvo”, é possível estender o pino do cilindro. Depois, estenda ou retraia o cilindro de telescopagem continuamente até o cilindro de telescopagem ser bloqueado com a seção telescópica.



Figura 4-43 Bloqueio do cilindro de telescopagem

c) Inserção de pino de seção de telescopagem



Figura 4-44 Inserção de pino de seção de telescopagem

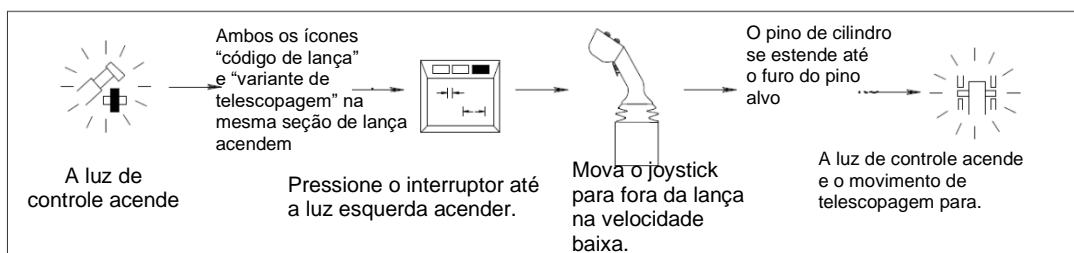

No programa, inicie o movimento “lança de telescópio para fora/dentro” lentamente se o pino da lança for liberado. Coloque o interruptor “pré-seleção de velocidade normal / baixa / extremamente baixa” na posição correta para aplicar a velocidade lenta o movimento de telescopagem. É recomendado ativar o joystick direito e realize telescopagem lenta da lança para dentro/fora, para impedir que o pino de lança exceda seu furo de pino alvo.

a) Remova o pino de seção de telescopagem

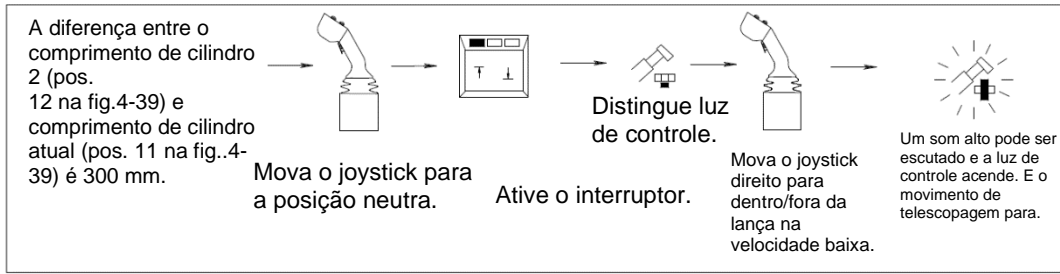

Figura 4-45 Inserção de pino de seção de telescopagem



Verifique se o cilindro de telescopagem está bloqueado e o pino de lança está operacional (os dois ícones à direita acendem) antes de remover os pinos das seções telescópicas.

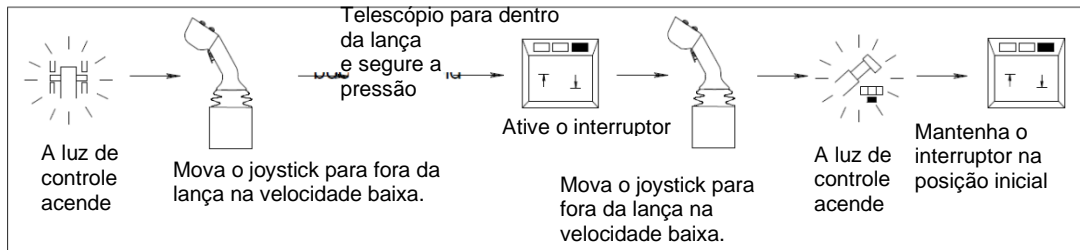

Se o ícone “lança com pinos inseridos” sair após o interruptor “pré-seleção de pino de cilindro/operação de pino de lança” for definido na posição correta, porém o ícone “lança com pinos retirados” não acende e o valor mostrado no manômetro se mantém por volta de 130 bar.

- 1) Pare de fechar o pino de lança.
- 2) Libere o pino de lança até o ícone “lança com pinos inseridos” acender.
- 3) Feche o pino de lança novamente.



- (1) Durante a telescopagem manual, realize a telescopagem lentamente com um ângulo grande de lança (a velocidade lenta é recomendada) se a seção de lança tiver os pinos retirados. O ícone “pino de lança operacional” deve acender durante o processo de telescopagem de entrada de lança. Acelere a operação de telescopagem após o cilindro de telescopagem retrair por um certo comprimento.
- (2) Na operação de telescopagem automática, examine se o ícone “pino de lança operacional” acende. Se não, engraxe as seções de lança.

b) Limitações da operação de telescopagem manual

O movimento “estender o cilindro de telescopagem” é desligado automaticamente para impedir que o cilindro se danifique, se os pré-requisitos a seguir forem atendidos:

- 1) Todas as seções de telescópio são telescopadas completamente.
- 2) O cilindro de telescopagem é desbloqueado.
- 3) O cilindro de telescopagem está na parte traseira da seção telescópica seção VI.
- 4) Estenda continuamente até a luz de controle “código de lança” da seção telescópica VI apagar.

c) Métodos de identificação em que a seção de lança está executando movimento

Observe a interface de monitor de telescopagem automática. Consulte a figura 4-46.



Figura 4-46 Exibição de seção telescópica atual

O ícone da seção telescópica I é destacado em verde, o que indica que a seção telescópica I deve realizar movimentos relevantes.

- d) Se a seção de lança tiver seus pinos retirados, o ícone 8 exibe o comprimento de cilindro 1 e ícone 7 exibe o comprimento de cilindro 2.

Nota:

O comprimento de cilindro 1 indica a posição para fechar o pino de lança. O comprimento de cilindro 2 indica a posição para abrir o pino de lança. Consulte a figura 4-39.

O comprimento do cilindro de telescopagem mostrado no ícone 9

varia com o movimento do joystick.

- e) O ícone 4 (seção telescópica alvo) indica que a seção de lança correspondente destacada em verde vai realizar movimentos relevantes no modo de telescopagem manual. Por exemplo, na tela “status de lança durante telescopagem manual” (figura 4-39), a seção destacada é a seção telescópica I. Dessa forma, a seção telescópica 1 deve realizar movimentos de telescopagem.



- (1) Na operação de telescopagem automática, o cilindro de telescopagem vai comandar a lança para retrain automaticamente, se a seção do telescópio tiver os pinos retirados (a luz de controle “lança com pinos retirados” acende).**

Se a lança não retrain por um longo período:

- Mude para telescopagem manual.
- Estenda a lança por 5 – 14 mm com velocidade lenta (segundo estágio).
- Retraia novamente com velocidade

lenta (segundo estágio). Nota:

Os movimentos de guindaste de “telescópio” têm 2 estágios:

- 1 (extremamente lento): desvia intermediariamente o joystick para a direita/esquerda
- 2 (lento): desvia totalmente o joystick direito para a direita/esquerda

Nesse caso, o operador deve observar os procedimentos acima.

Caso contrário, há risco de grande impacto na lança durante a retração.

- (2) Se o pino de lança não puder ser fechado durante o processo de telescopagem na lança automaticamente:**

- Mude para telescopagem manual.
- Abra o pino de lança manualmente até o ícone “Lança com pinos inseridos” acender.
- Mude para telescopagem automática novamente.

Se o pino de lança ainda não puder ser fechado, repita os passos acima.

- (3) Se o ícone “falha de telescopagem automática” acender durante a operação de telescopagem automática, com a condição que o guindaste funcionou por um longo tempo:**

- Mude a telescopagem automática para telescopagem manual.
- Estenda o cilindro de telescopagem com velocidade lenta (segundo estágio), até o comprimento do cilindro de telescopagem variar.

Se a luz de controle “pino de lança operacional” acender

durante a extensão do cilindro, retraia o cilindro de telescopagem até a luz de controle “pino de cilindro excedendo seu furo alvo” e luz de controle “o pino de cilindro não atinge seu furo alvo” acenderem todas.

- Mude para telescopagem automática novamente.

Consulte o manual do operador do limitador de momento de carga para instruções de operação.



Precauções especiais de uso de limitador de momento de carga:

1. O limitador de momento de carga pode ser usado para impedir tombamento de guindaste, ruptura de lança, ou ferimentos devido a sobrecarga do guindaste em canteiros de obra. Entretanto, não deve depender exclusivamente do operador. Quando a capacidade de levantamento nominal exibida nessa tela não estiver em conformidade com as tabelas de capacidade de levantamento, as últimas devem prevalecer para determinar a capacidade real de levantamento.
2. O ajuste do modo de operação correto é um pré-requisito de uso do limitador de momento de carga e guindaste. Apenas um operador qualificado tem permissão para ajustar o modo de operação. É proibido definir um modo de operação que não se conforme à condição real de operação.
3. O limitador de momento de carga deve ser depurado pelo pessoal técnico.
4. Quando “sobrecarga pesada” aparecer na tela, a limitação dos movimentos em uma direção perigosa não pode ser derivada. Bobine o guincho para abaixar a carga até o piso.
5. Quando “sobrecarga pesada” e “LMI” (na parte inferior) aparecerem na tela, uma contagem regressiva de 15 minutos “15:00” é exibida, a limitação de movimentos em uma direção perigosa não pode ser derivada. Pressione e segure o interruptor de derivação para ativar “LIM” para piscar. A limitação pode ser derivada por 15 minutos temporariamente, porém isso é pretendido para ser feito apenas no processo de manutenção.
6. Quando “LMI” aparecer no canto superior direito da tela, a limitação de movimentos em uma direção perigosa é removida temporariamente.

4.3 Colocação em operação do guindaste

4.3.1 Verificações antes da colocação em operação

Verifique se os pré-requisitos a seguir são atendidos antes da colocação em operação:

- a) Inspeção do nível de óleo do motor
 - 1) O guindaste foi nivelado.
 - 2) Retire a vareta e limpe-a.
 - 3) Reinsira no óleo e retire novamente.
 - 4) Verifique se o nível de óleo está entre as marcações MIN. e MAX.

AVISO

Se o nível de óleo for inferior à marcação MIN., abasteça com óleo. Caso contrário, o motor vai ser danificado gravemente!

- b) Verificação do nível de óleo
O nível de óleo no tanque de óleo hidráulico deve estar entre as marcações MIN. e MAX. Abra a válvula corredeira de desligamento, para conectar o tanque de óleo hidráulico com a linha de óleo. Como abrir a válvula corredeira de desligamento:

- 1) Puxe a manopla.
- 2) Gire a manopla.

Consulte a figura 4-47.



Figura 4-47 Tanque de óleo hidráulico

- c) Verificação de reserva de combustível
A reserva de combustível é exibida no medidor de combustível. Verifique a reserva de combustível e adicione combustível, se necessário.

AVISO

Elimine o ar do sistema de combustível antes de adicionar combustível. Se o tanque de combustível tiver operado a seco, sempre elimine o ar de todo o sistema de combustível. Não opere o tanque de combustível a seco!

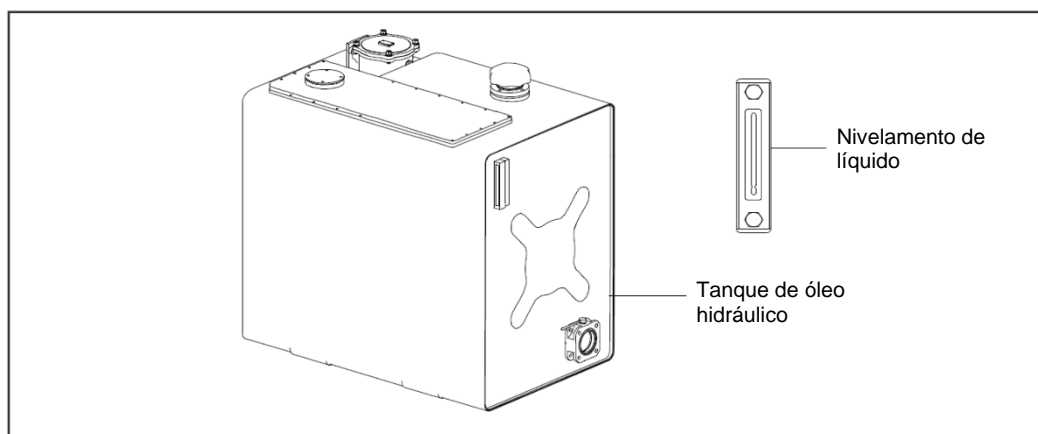
- d) Verificação do nível de fluido refrigerante
Verifique o fluido refrigerante para garantir que o fluido refrigerante do motor esteja no nível correto. Adicione mais, se estiver abaixo do nível de motor frio.
- e) Verificação de condições gerais do guindaste
 - 1) Verifique o status de lubrificação de cada peça móvel e certifique-se que todas as peças móveis estão lubrificadas. Adicione graxa, se necessário.
 - 2) Certifique-se que o guindaste está apoiado adequadamente em uma superfície de suporte de carga nivelada e foi configurado horizontalmente.
 - 3) Certifique-se que a engrenagem da conexão de mancal de giro está limpa.
 - 4) Certifique-se que as partes dianteira e traseira do resfriador de óleo e radiador do A/C foram limpas e não estão bloqueadas.
 - 5) Certifique-se que não há pessoas ou objetos na zona de perigo do guindaste.
 - 6) Certifique-se que os tambores de cabo/corda e sensores estejam sem neve e gelo.
 - 7) Certifique-se que não há peças soltas na superestrutura ou lança telescópica.
 - 8) Certifique-se que os joysticks na cabine do operador estão na posição neutra antes de ativar PTO.
 - 9) Certifique-se que todas as alavancas de controle estabilizadoras estão na posição neutra.
 - 10) Certifique-se que o freio de estacionamento está aplicado.

4.3.2 Partida e parada do motor

Para partida e parada do motor na cabine do condutor, consulte as instruções de operação no capítulo 3 *Operação – chassi de guindaste*.

A partida e parada do motor na cabine do operador devem ser realizadas de acordo com as instruções de operação a seguir.

- a) Parada do motor
Em condições normais, pressione e segure o botão “Parada do motor” no painel de controle por 1 a 2 segundos, para desligar o motor.
- b) Partida do motor
É possível pressionar o botão “partida do motor” para ligar o motor, se os pré-requisitos a seguir forem atendidos:
 - 1) PTO foi ativado.
 - 2) A transmissão está na posição necessária.

4.4 Dispositivos de segurança

4.4.1 Medidor de nivelamento

Um medidor de nivelamento está instalado próximo do mecanismo de operação estabilizadora em cada lado do quadro de chassi. Sua tela exibe vividamente o nivelamento geral do quadro de chassi, com informações exibidas em simetria nas duas telas dos dois lados. Considere a tela de exibição do lado direito como exemplo, como mostrado na figura 4-48.

As indicações de direção na tela são como segue:

Esquerda: representa a cabeça do quadro de chassi;

Direita: representa a extremidade do quadro de chassi;

Para cima: representa o lado direito do quadro de chassi;

Para baixo: representa o lado esquerdo do quadro de chassi.



Figura 4-48 Medidor de nivelamento

Lógica de iluminação das luzes indicadoras:

- Apenas uma linha das luzes indicadores em uma das 4 direções acende em qualquer momento dado.
- A iluminação das luzes indicadoras em qualquer direção indica a perda de nivelamento nessa direção e o ajuste do cilindro vertical dos estabilizadores correspondentes é necessário.
- Se a luz indicadora mais externa acender em qualquer direção, ela indica que o ângulo de inclinação nessa direção excedeu o limite ($0,5^{\circ}$).
- Quando todas as luzes indicadoras estiverem piscando, isso indica que há uma falha conexão de barramento CAN.

**CUIDADO**

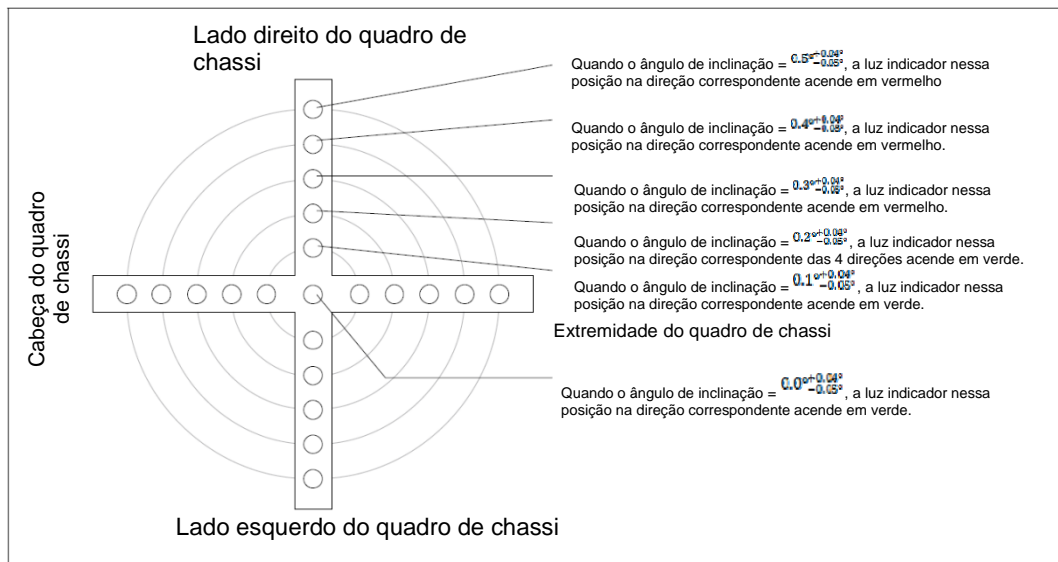
Mantenha o ângulo de inclinação do quadro do chassi inferior a 0,3, caso contrário há um risco mais de acidente!

**ADVERTÊNCIA**

Ajuste o nivelamento do guindaste após o contrapeso ser alterado.

**PERIGO**

É estritamente proibido ajustar o nivelamento do guindaste durante as operações.

4.4.2 Interruptor de fim de curso de elevação

Os interruptores de fim de curso de elevação na lança principal, braço e roldana de cabeça são desenvolvidos para impedir que o bloco de gancho colida com a polia do cabo.

Quando a distância detectada entre o bloco de gancho e a polia for inferior à de segurança, o interruptor de fim de curso de elevação é acionado e a cigarra é ativada. Os movimentos de guindaste “aceleração de guinchos” e “telescópio para fora” são desligados. Nesse momento, apenas os movimentos de guindaste “bobinamento de guinchos”, “grua para cima” e “telescópio para dentro” podem ser ligados. Consulte a figura 4-49.



Figura 4-49 Interruptor de fim de curso de elevação

Ative o interruptor de chave de derivação, para derivar o desligamento durante o comissionamento e manutenção.

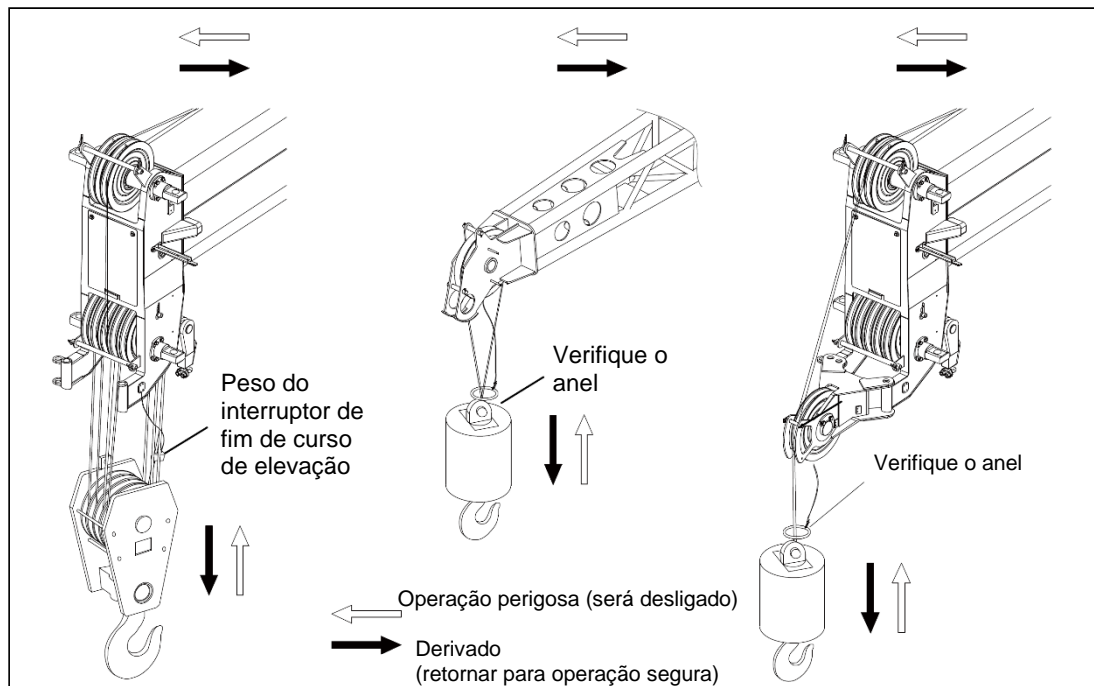

Não use o interruptor de chave de derivação ao realizar operações comuns de guindaste.

A conexão e instalação de interruptores de fim de curso de elevação no braço, lança de extremidade e roldana de cabeça são como segue:

- a) Quando o braço for utilizado:
 - 1) Remova o plugue na traseira da seção do braço da caixa.
 - 2) Conecte o plugue no soquete na cabeça da lança principal. Consulte a figura 4-50.



Figura 4-50 Instalação do interruptor de fim de curso de elevação no braço



Na condição de operação do braço, conecte o chicote de fios do interruptor de fim de curso de elevação do guincho auxiliar para o chicote de fios do cabo antecipadamente. E, dessa forma, o interruptor de fim de curso de elevação do guincho auxiliar é válido.

Antes de desmontar o braço, desconecte o chicote de fios do interruptor de fim de curso de elevação do guincho auxiliar para o chicote de fios do cabo, a não ser que o chicote esteja quebrado.

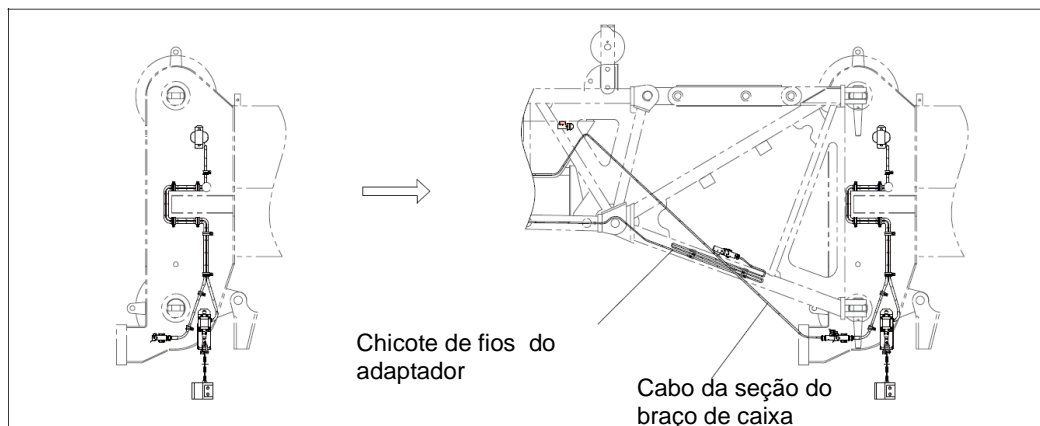
- b) Quando a roldana de cabeça for utilizada:
 - 1) Remova o interruptor de fim de curso de elevação no braço e instale conforme a figura abaixo.
 - 2) Conecte o plugue do interruptor de fim de curso de elevação no soquete na cabeça de lança principal. Consulte a figura 4-51.



Figura 4-51 Instalação do interruptor de fim de curso de elevação na roldana de cabeça

4.4.3 Interruptor de fim de curso de abaixamento

Para impedir que o cabo de arame seja acelerado automaticamente após ser bobinado completamente, os interruptores de fim de curso de abaixamento instalados nos guinchos vão desligar automaticamente os movimentos “bobinamento de guinchos”, se houver apenas 3 enrolamentos de cabo nos guinchos.

Nesse caso, a luz de advertência acende, a cigarra ativa o alarme e apenas o movimento ascendente do gancho é permitido. Durante o comissionamento e manutenção, ative o interruptor de derivação de limite para derivar o desligamento. Consulte a figura 4-52.

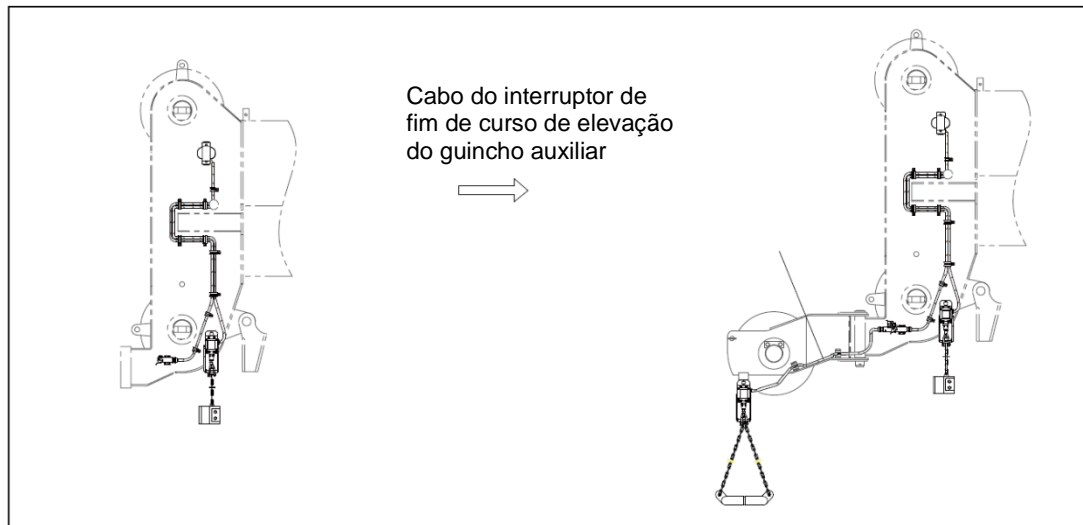

Não use o interruptor de chave de derivação ao realizar operações comuns de guindaste.



Figura 4-52 Interruptor de fim de curso de abaixamento

4.4.4 Dispositivos hidráulicos de segurança

4.4.4.1 Válvulas de alívio no sistema hidráulico

As válvulas de alívio no sistema hidráulico podem impedir que a pressão no circuito suba excessivamente, evitando dessa forma que a bomba hidráulica e motor hidráulico se danifiquem e o sistema hidráulico seja sobrecarregado.

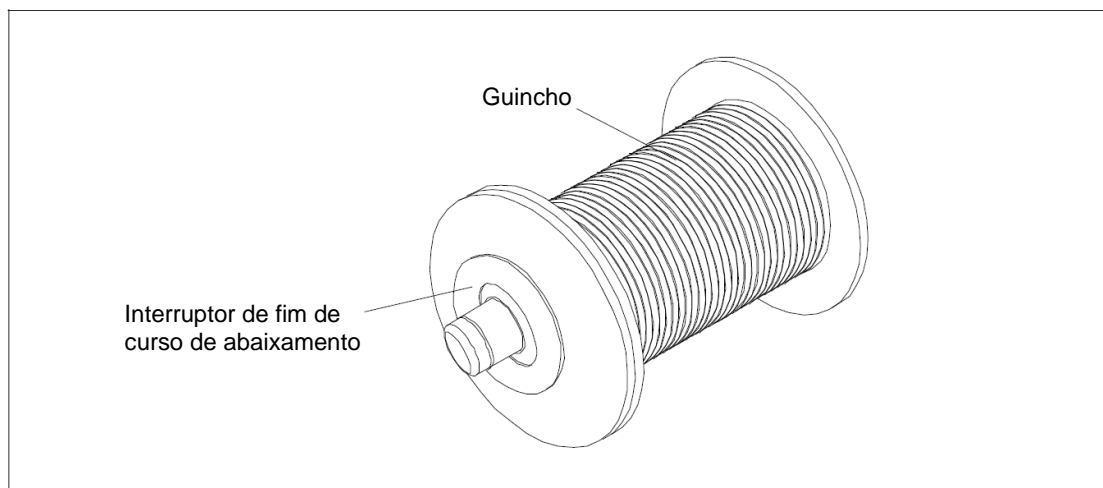
4.4.4.2 Dispositivo de bloqueio estabilizador

Se o tubo de óleo de pressão alta conectado ao cilindro vertical for danificado, o bloqueio hidráulico de duas vias no circuito hidráulico estabilizador pode bloquear o óleo de pressão em ambos os lados do cilindro da retranca para impedir que o estabilizador se retraia ou estenda e permite dessa forma a operação segura do guindaste.

4.4.4.3 Dispositivo de bloqueio de movimento de guindaste “grua para cima”

Se o tubo de óleo de pressão alta no circuito hidráulico do cilindro de grua for danificado, a válvula de balanço no circuito hidráulico pode bloquear o óleo hidráulico no lado do pistão do cilindro de grua imediatamente, para impedir que o movimento ascendente se volte para baixo, permitindo dessa forma a operação segura do guindaste.

4.4.4.4 Dispositivo de bloqueio de movimento de guindaste “telescópio para fora”

Se o tubo de óleo de pressão alta no circuito hidráulico do cilindro de telescopagem for danificado, a válvula de balanço no circuito hidráulico pode bloquear o óleo hidráulico no lado do pistão do cilindro de telescopagem imediatamente, para impedir que as seções do telescópio se retraiam naturalmente, permitindo dessa forma a operação segura do guindaste.

4.4.4.5 Sistema de advertência de sobrepresão de 5ª. retranca

Para impedir que a dianteira do veículo sofra curvatura e deformação causadas por sobrepresão na 5ª. retranca, um relé de pressão é instalado no cilindro de óleo para a 5ª. retranca. Quando realizar uma operação de levantamento sobre a dianteira, o dispositivo de detecção de pressão instalado na 5ª. retranca pode detectar a pressão no sistema hidráulico e enviar o sinal de pressão para o sistema de controle de guindaste. Quando a pressão exceder o valor de segurança definido, a luz de advertência “pressão alta da 5ª. retranca” acende e a cigarra é ativada.



Não realize operação de levantamento pela frente quando a luz de advertência “pressão alta da 5ª. retranca” acende e a cigarra envia advertência acústica.

4.4.4.6 Monitoramento de pressão do sistema

As pressões máximas são como segue:

Válvula de controle de superestrutura 1:	Válvula de controle de superestrutura 2:
Pressão piloto: 3,5 MPa	Pressão piloto: 3,5 MPa
Válvula de alívio principal: 34 MPa \pm 0,5 MPa	Válvula de alívio principal: 35 MPa
Válvula de alívio de bobinamento do guincho principal:	Válvula de alívio de levantamento de cilindros esquerdo e direito de contrapeso:
4 MPa – 5 MPa	20 MPa \pm 0,5MPa
Válvula de alívio de bobinamento do guincho principal: 4 MPa – 5 MPa	Válvula de alívio de abaixamento de cilindros esquerdo e direito de contrapeso:
Válvula de alívio de grua para baixo:	5 MPa \pm 0,5MPa
3 MPa – 4 MPa	Válvula de alívio de inclinação descendente da cabine do operador: 4 MPa – 5 MPa
Válvula de alívio de telescopagem para fora:	Válvula de alívio de inclinação ascendente da cabine do operador: 4 MPa – 5 MPa
13 MPa – 15 MPa	Válvula de alívio de retração de pino de lança/pino de cilindro: 9 MPa – 10 MPa
Válvula de alívio de telescopagem para dentro:	Válvula de segurança de retração de pino de lança/pino de cilindro: 9 MPa – 10 MPa
19 MPa – 20 MPa	
Válvula de alívio de realimentação:	
30 MPa – 31 MPa	

Válvula de alívio principal válvula de giro com amortecimento: 12 MPa

Válvula de alívio da válvula de controle de chassi: 18 MPa

Pressão de ajuste da válvula de segurança: 8 MPa

Pressão de advertência da 5ª. retranca: 20 MPa.

4.4.5 Operação de derivação

Quando o interruptor de fim de curso de fim de curso de elevação ou abaixamento for acionado, ou quando o sensor de guindaste detectar que o peso da carga for superior ao peso da carga no sistema, o sistema vai desligar os movimentos perigosos e a cigarra vai ativar.

Se necessário, desvie o desligamento via interruptor de chave de derivação no painel de instrumentos. Para mais detalhes, consulte a seção 4.1.2. Para movimentos permitidos ou bloqueados em condições de sobrecarga, superenrolamento e rebaixamento excessivo, consulte a tabela 4-1.

Tabela 4-1 Movimentos permitidos ou bloqueados em condições de sobrecarga, superenrolamento e rebaixamento excessivo

Operação	Guincho principal		Guincho auxiliar		Grua		Giro		Telescópio	
	para cima	para baixo	para cima	para baixo	para cima	para baixo	esquerda	direita	para fora	para dentro
Sobrecarga	×	✓	×	✓	✓	×	✓	✓	✓	✓
Superenrolamento	×	✓	×	✓	✓	×	✓	✓	×	✓
Rebaixamento excessivo	✓	×	✓	×	✓	✓	✓	✓	✓	✓

Nota:

“x” significa que o sistema vai desligar o movimento. “✓” significa que o sistema não vai desligar o movimento.



Se houver necessidade de levantar ou abaixar o gancho um pouco em condições especiais, o operador pode ativar o “interruptor de chave de derivação” no painel de instrumentos, para desviar os movimentos de desligamento. Essa operação deve ser realizada com muito cuidado, para evitar acidentes. Não realize telescopagem da lança telescópica com uma carga suspensa. O ângulo de lança deve exceder 78°. Caso contrário, você deve assumir total responsabilidade por todas as consequências resultantes.

4.4.6 Sistema de advertência de velocidade do vento

O anemômetro está instalado na cabeça de lança principal para detectar a velocidade do vento em tempo real. Consulte a figura 4-53. A velocidade do vento é exibida no monitor do limitador de momento de carga. Se a velocidade real do vento exceder o valor máximo enquanto o guindaste estiver em operação, execute as seguintes tarefas:

- a) Pare o trabalho (abaixe a carga com segurança).
- b) Retraia a lança.
- c) Acondicione a lança corretamente.

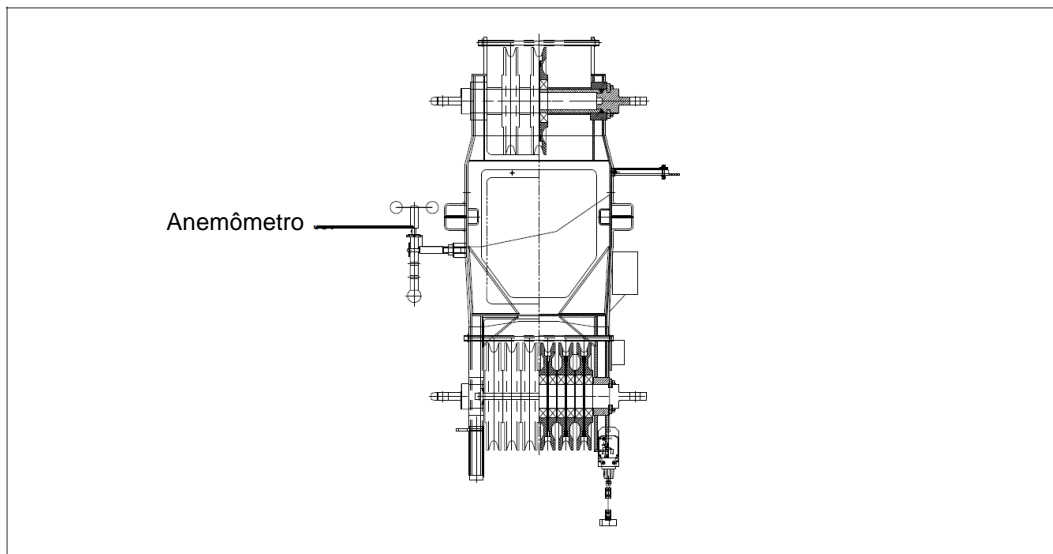
**Figura 4-53 Anemômetro****! PERIGO**

O guindaste pode tombar!

Se o guindaste for operado a velocidades do vento superiores ao valor máximo permitido, ele pode tombar!

4.4.7 Botão de parada de emergência

É possível encontrar o botão de parada de emergência no painel de interruptor na cabine do operador. Ao apertar o botão, todas as operações do guindaste param imediatamente. Gire o botão no sentido horário para liberá-lo e continue as operações comuns do guindaste.

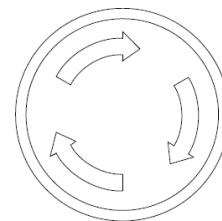
**! ADVERTÊNCIA**

Use o botão apenas em caso de emergência clara!

4.5 Operação do guindaste

4.5.1 Preparações para operação do guindaste

Certifique-se que as verificações a seguir são realizadas antes da operação:

- a) Avalie a condição da carga antes do levantamento.
- b) Examine a posição do guindaste, condição do solo e condição de suporte da superfície.
- c) Examine os cabos de arame (incluindo a extremidade dos cabos, tambor de enrolamento e polias).
- d) Examine o nível de líquido e fonte de alimentação do guindaste.



CUIDADO

- (1) **Examine indicador do nível de combustível, para certificar que a reserva de combustível esteja superior a 1/4 da capacidade do tanque.**
 - (2) **O nível de óleo no tanque de óleo hidráulico deve estar entre as marcações MIN. e MAX. na condição de condução.**
- e) A área de carga e trabalho deve estar visível e sem obstáculos nela. Examine o sistema de comunicação do operador e supervisor, para garantir que nada prejudique a operação.
 - f) Examine o funcionamento dos dispositivos de segurança.
 - g) Mantenha a comunicação entre o operador e o manobrador.



ADVERTÊNCIA

Risco de acidente!

Perigo de danos ao guindaste!

Sempre opere os joysticks lenta e sensivelmente.



PERIGO

Certifique-se que não haja obstáculos na área de operação do guindaste e nem pessoas na zona de perigo. Emite um sinal curto de advertência (buzina) antes de iniciar um movimento de guindaste.

4.5.2 Retranca

Ambos os lados do quadro do chassi do veículo têm os itens a seguir:

- Interruptor de controle de acelerador
- Alavancas de controle estabilizadoras
- Medidor de nivelamento.

É possível operar as alavancas de controle para estender ou retrain os estabilizadores simultânea ou independentemente. Consulte a figura 4-54.



Figura 4-54 Retranca

Pos.	Descrição	Pos.	Descrição
1	Medidor de nivelamento elétrico	6	Caixa dianteira estabilizadora
2	Viga deslizante 1	7	Cilindro horizontal
3	Cilindro vertical	8	Viga deslizante 2
4	Interruptor de controle de acelerador	9	Placa estabilizadora
5	Alavancas de controle estabilizadoras		

AVISO

Estenda os estabilizadores antes da operação do guindaste.

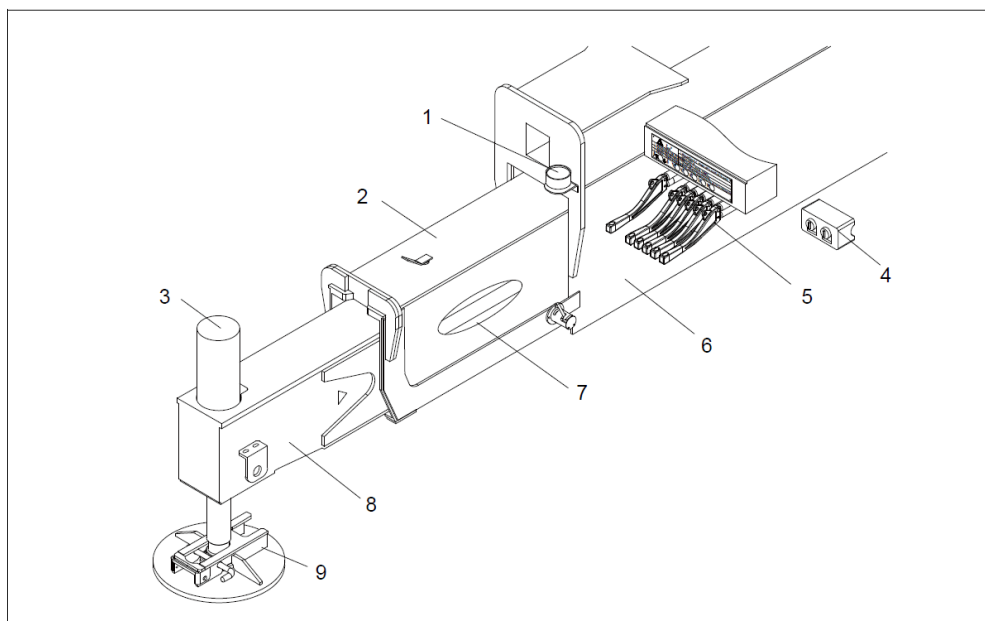
Certifique-se de realizar todo o trabalho em solo nivelado que seja rígido. O solo deve suportar mais do que a capacidade de suporte de carga.

Use material (como madeira) abaixo das placas estabilizadoras, se a área de trabalho for macia ou não plana.

4.5.2.1 Alavancas de controle estabilizadoras

Para níveis de controle estabilizadores, consulte a figura 4-55.



Figura 4-55 Alavancas de controle estabilizadoras

As alavancas de controle estabilizadoras são mostradas na figura 4-55.

a) Ilustrações de operação e pontos de atenção estão impressos no rótulo da retranca.

b) Alavanca de controle 1: estenda ou retraia o cilindro horizontal ou vertical

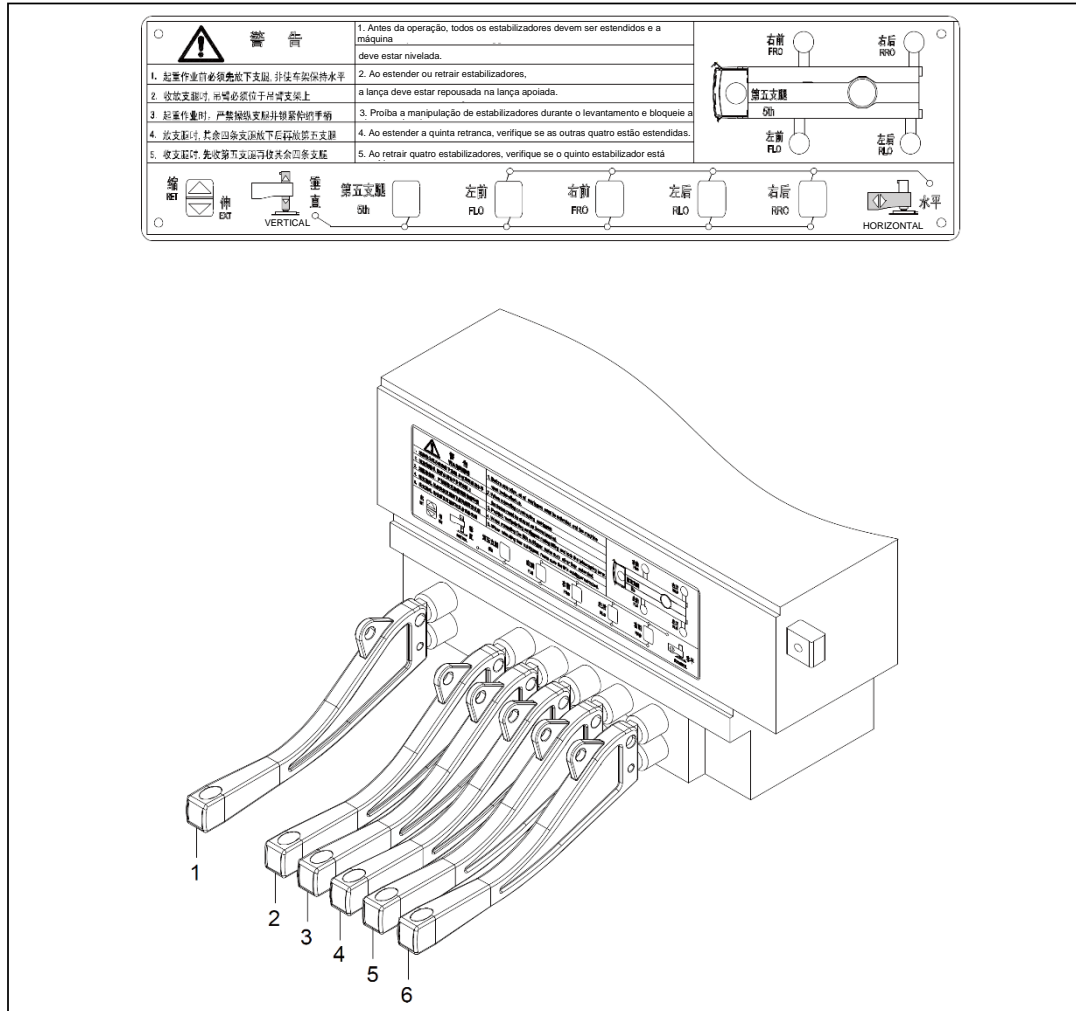
1) Mova a alavanca 1 para cima: retraia o cilindro horizontal/vertical.

2) Posição neutra: pare o movimento do cilindro.

3) Mova a alavanca 1 para baixo: estenda o cilindro horizontal/vertical.

c) Alavanca de controle 3: selecione a retranca dianteira esquerda

Alavanca de controle 4: selecione a retranca dianteira direita

Alavanca de controle 5: selecione a retranca traseira esquerda

Alavanca de controle 6: selecione a retranca traseira direita

Mova as alavancas 3, 4, 5 e 6 juntamente com a alavanca 1 para iniciar os movimentos correspondentes.

- 1) Mova as alavancas 3, 4, 5 e 6 para cima e mova a alavanca 1 para cima ou para baixo: estenda/retraia os cilindros horizontais.
- 2) Mova as alavancas 3, 4, 5 e 6 para baixo e mova a alavanca 1 para cima ou para baixo: estenda/retraia os cilindros verticais.

d) Alavanca de controle 2: selecione a 5ª. retranca

Mova a alavanca 2 para baixo e mova a alavanca 1 para cima: retraia a 5ª. retranca. Mova a alavanca 2 para baixo e mova a alavanca 1 para baixo: estenda a 5ª. retranca.

CUIDADO

- (1) Durante a operação dos estabilizadores, gire o interruptor de controle de acelerador no sentido horário para aumentar suas velocidades de trabalho.
- (2) Ao retrain qualquer cilindro vertical, o cilindro da 5ª. retranca vai ser retraído simultaneamente.

ADVERTÊNCIA

Não estenda nem retraia os cilindros horizontais após as placas estabilizadoras estarem em contato com o solo!

4.5.2.2 Extensão estabilizadora

- a) Remova o pino da viga deslizante. Consulte a figura 4-56.



Figura 4-56 Remoção de viga deslizante

- b) Execute os passos a seguir, como mostrado:
 - 1) Fique do lado esquerdo (ou direito) do guindaste.
 - 2) Mova as alavancas 3 e 5 (ou 4 e 6) para cima.
 - 3) Mova a alavanca 1 para baixo até a posição intermediária marcar “◁” estão expostas, o que significa que as vigas deslizantes estão estendidas intermediariamente.
 - 4) Continue a mover a alavanca 1 até estender totalmente as vigas

deslizantes.

- 5) Mova as alavancas até as posições neutras, até as vigas deslizantes estarem totalmente estendidas.
- 6) Estenda as vigas deslizantes no outro lado do guindaste, de acordo com os mesmos passos.

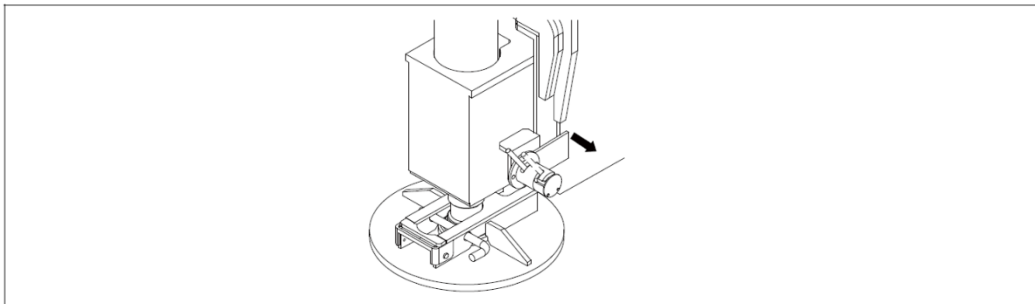

Figura 4-57 Estender cilindro horizontal



As marcações de posição intermediária “ \triangle ” nas vigas deslizantes devem estar completamente expostas e os pinos devem ser protegidos, se o guindaste estiver operando com estabilizadores estendidos intermediariamente. Caso contrário, o guindaste vai tombar.

- c) Execute os passos a seguir, como mostrado:
 - 1) Fique do lado esquerdo (ou direito) do guindaste.
 - 2) Mova as alavancas 3 e 5 (ou 4 e 6) para baixo.
 - 3) Mova a alavanca 1 para baixo e estenda completamente os cilindros verticais.
 - 4) Vá para o outro lado do guindaste para estender os cilindros verticais no outro lado. Consulte a figura 4-58

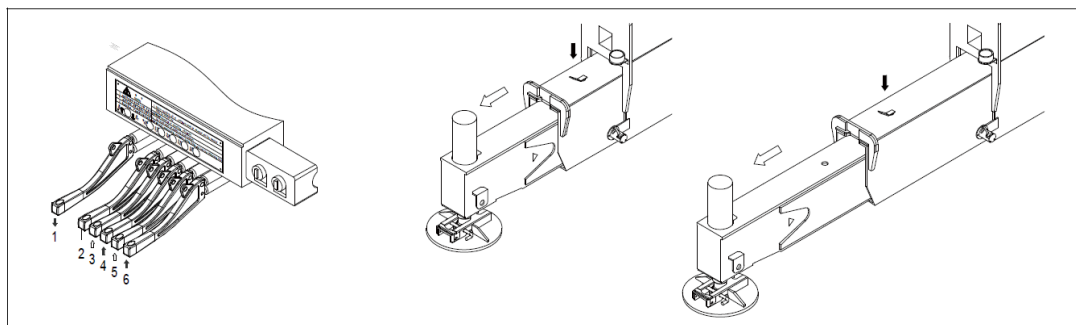

Figura 4-58 Estender cilindro vertical

Após todos os cilindros verticais estabilizadores estarem totalmente estendidos, observe se há uma luz indicadora vermelha, que ilumina (indicando que o ângulo de inclinação do quadro de chassi exceder $0,3^\circ$) na tela do medidor de nivelamento. Se for o caso, ajuste os cilindros verticais

estabilizadores de acordo com os passos listados na tabela abaixo, para obter o nivelamento do quadro de chassi. Após o ajuste, coloque a alavanca em sua posição neutra.

A figura 4-59 mostra a tela no lado esquerdo do quadro de chassi. A tela do lado direito está em simetria.

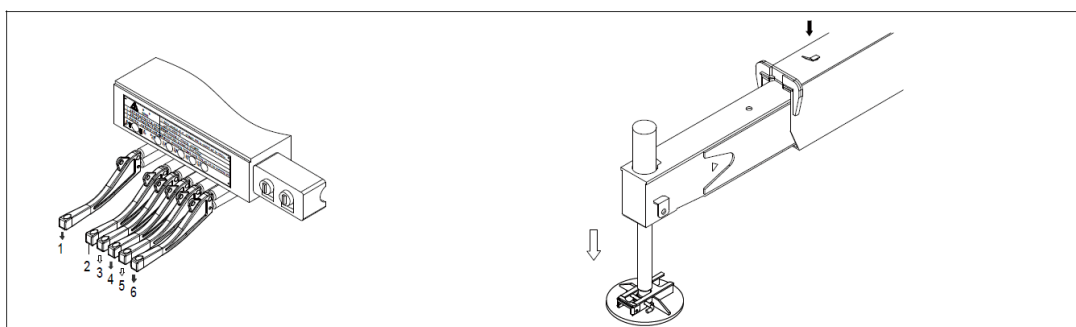
O nivelamento do quadro de chassi é atingido quando houver apenas a luz indicadora no centro que ilumina, indicando um ângulo de inclinação de 0 graus.



Figura 4-59 Luzes indicadoras no medidor de nivelamento (lado esquerdo)

Ângulo de inclinação do quadro de chassi geral	Status de luz indicadora de nivelamento	Operações de cilindros verticais estabilizadores que devem ser feitas
A cabeça do quadro de chassi é $0,3^\circ / 0,4^\circ / 0,5^\circ$ ou acima	A luz indicadora no 3º/4º/5º círculo do lado esquerdo acende em vermelho ou a do 5º círculo pisca em vermelho	Opere o nível de controle para estender os estabilizadores dianteiros esquerdo e direito, ou retrainha os estabilizadores traseiros esquerdo e direito
A extremidade do quadro de chassi é $0,3^\circ / 0,4^\circ / 0,5^\circ$ ou acima	A luz indicadora no 3º/4º/5º círculo do lado direito acende em vermelho ou a do 5º círculo pisca em vermelho	Ajuste na direção inversa em relação ao indicado acima
O lado direito do quadro de chassi é $0,3^\circ / 0,4^\circ / 0,5^\circ$ ou acima	A luz indicadora no 3º/4º/5º círculo do lado superior acende em vermelho ou a do 5º círculo pisca em vermelho	Opere o nível de controle para estender os estabilizadores dianteiros e traseiros à direita, ou retrainha os estabilizadores dianteiros e traseiros à esquerda
O lado esquerdo do quadro de chassi é $0,3^\circ / 0,4^\circ / 0,5^\circ$ ou acima	A luz indicadora no 3º/4º/5º círculo do lado inferior acende em vermelho ou a do 5º círculo pisca em vermelho	Ajuste na direção inversa em relação ao indicado acima
O ângulo de inclinação nas quatro direções é inferior a $0,3^\circ$	Apenas a luz indicadora no centro ou as do primeiro/segundo círculo acendem em verde	Não há necessidade de ajuste de estabilizadores

- d) Libere a alavanca de controle e coloque na posição neutra quando o guindaste estiver nivelado.
- e) Quando o guindaste estiver operando sobre a área dianteira com o mesmo desempenho de levantamento que sobre a área lateral e traseira, a 5ª retranca deve ser utilizada.

Estenda os estabilizadores nos passos a seguir:

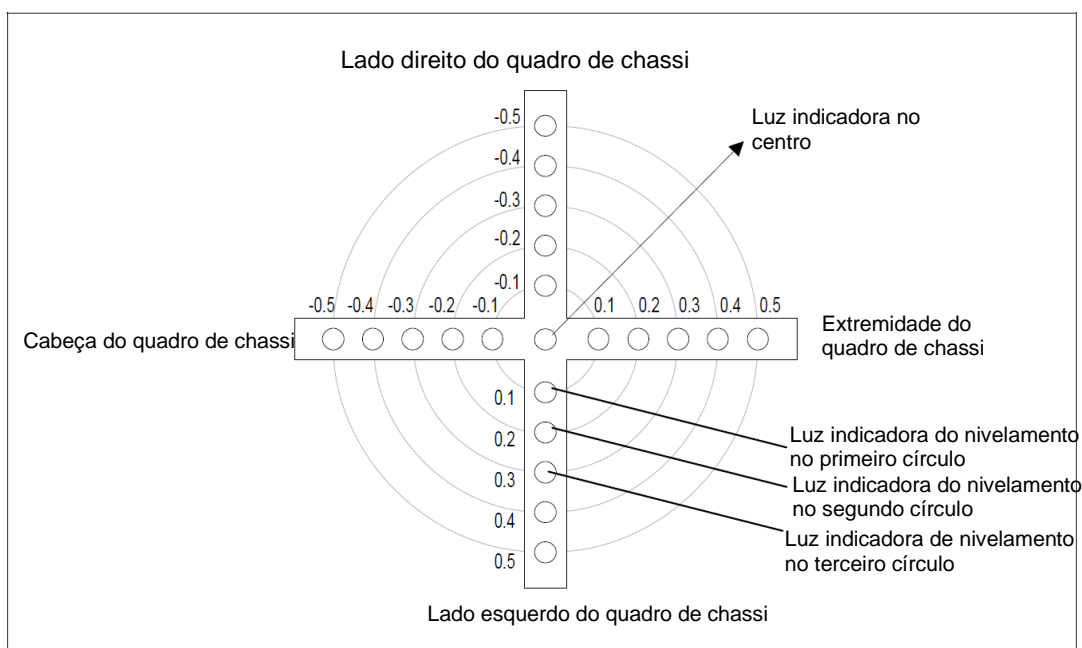
- Empurre a alavanca de controle de seleção (2) da 5ª retranca para baixo;
- Empurre a alavanca de controle (1) para baixo para estender a 5ª retranca.
- Mantenha uma folga de 5-10mm da retranca até o solo, como mostrado na figura 4-60.



Figura 4-60 Extensão da 5ª retranca

- f) Insira os pinos estabilizadores antes de operações normais de levantamento.

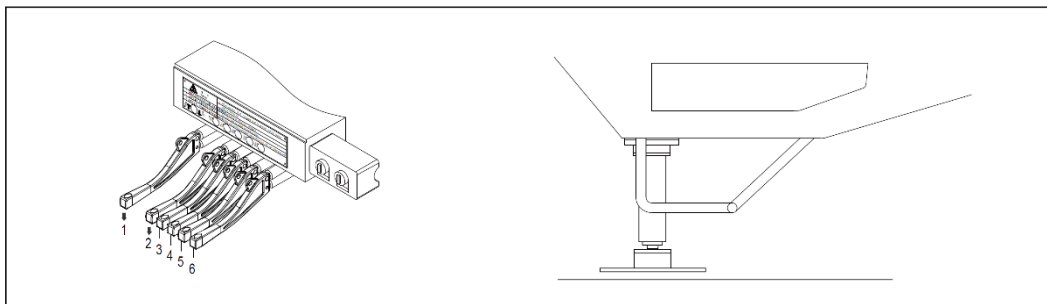

CUIDADO

O nível de controle de telescopagem de cilindro (1) pode retornar para sua posição neutra automaticamente após ser liberado, enquanto outras alavancas de controle devem ser retornadas para sua posição neutra manualmente.



ADVERTÊNCIA

Risco de acidente!

Se a referência horizontal do medidor de nivelamento variar devido a forças externas, etc., o medidor de nivelamento deve ser alinhado por técnicos especializados novamente.

Se isso não for observado, há risco de acidente.

4.5.2.3 Retração estabilizadora

AVISO

Após a operação do guindaste, faça as tarefas a seguir na sequência:

- (1) Pare o trabalho (abaixe a carga com segurança).
- (2) Retraia a lança.
- (3) Acondicione a lança corretamente.

- (4) Retraia a 5ª retranca.**
- (5) Retraia todos os outros estabilizadores.**

a) Remova o pino da viga deslizante. Consulte a figura 4-61.



Figura 4-61 Remoção de viga deslizante

b) Retraia a 5ª retranca (consulte a figura 4-62):

- 1) Mova a alavanca 2 para baixo.
- 2) Mova a alavanca 1 para cima até a 5ª retranca estar totalmente retraída.

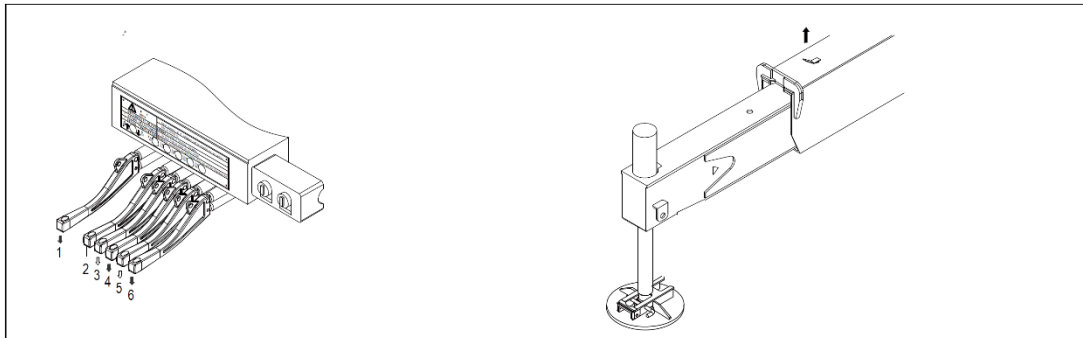

Figura 4-62 Retrair a 5ª retranca

c) Retraia os cilindros verticais:

- 1) Fique do lado esquerdo (ou direito) do guindaste.
- 2) Mova as alavancas 3, 4, 5 e 6 para baixo.
- 3) Mova a alavanca 1 para cima, para retraindo os cilindros verticais completamente. Consulte a figura 4-63.

Figura 4-63 Estender cilindro vertical

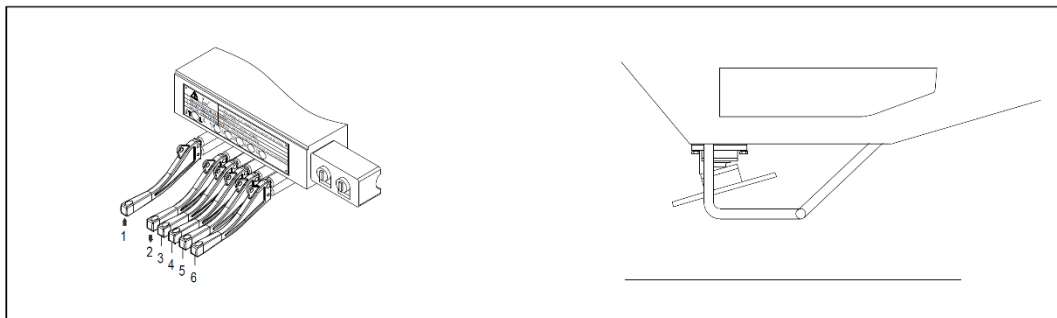
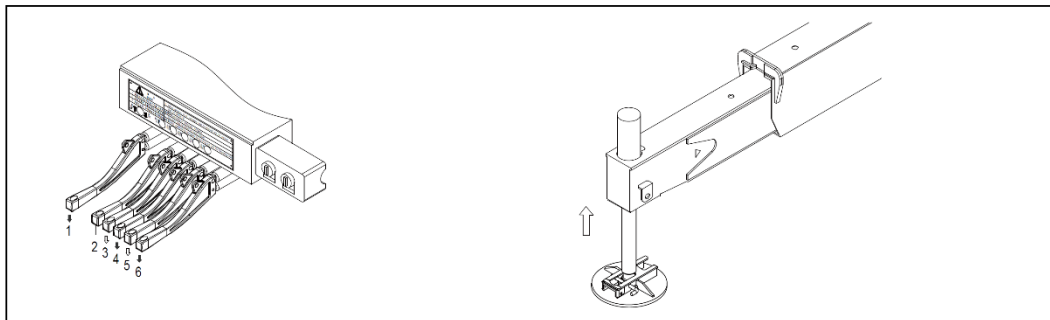
- d) Retraia as vigas deslizantes:
- 1) Fique do lado esquerdo (ou direito) do guindaste.
 - 2) Mova as alavancas 3, 4, 5 e 6 para cima.
 - 3) Mova a alavanca 1 para cima, para retrain as vigas deslizantes completamente. Consulte a figura 4-64.

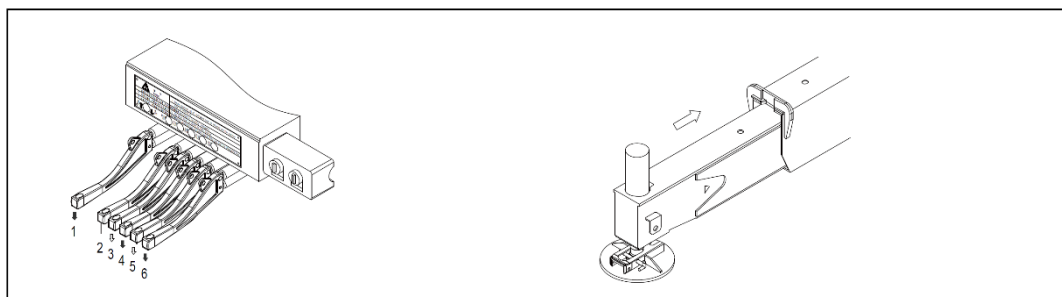
Figura 4-64 Retrair cilindro horizontal

- e) Instale os pinos de retenção estabilizadores. Consulte a figura 4-65.

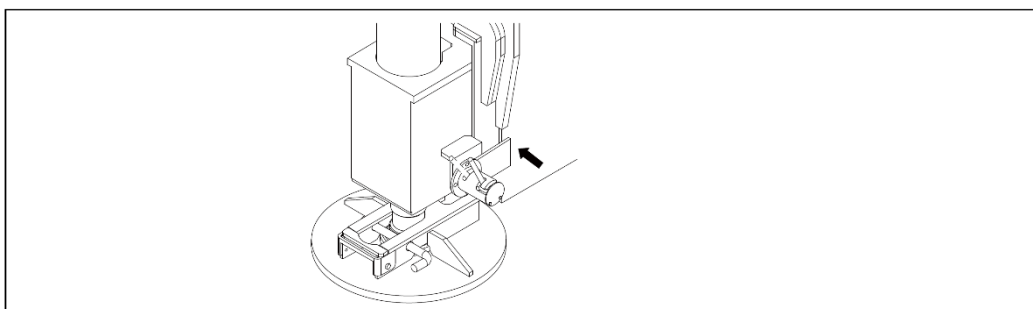
Figura 4-65 Instale os pinos de retenção estabilizadores

4.5.2.4 Instale e remova as placas estabilizadoras

A placa estabilizadora é mostrada na figura 4-66.



Figura 4-66 Placa estabilizadora

a) Instalação

Antes de estender os estabilizadores, remova o pino do soquete das placas estabilizadoras e retire as placas de apoio estabilizadoras. Quando o furo estiver alinhado com o cilindro vertical, instale o pino do soquete.

Peso da placa estabilizadora: aproximadamente 35 kg.

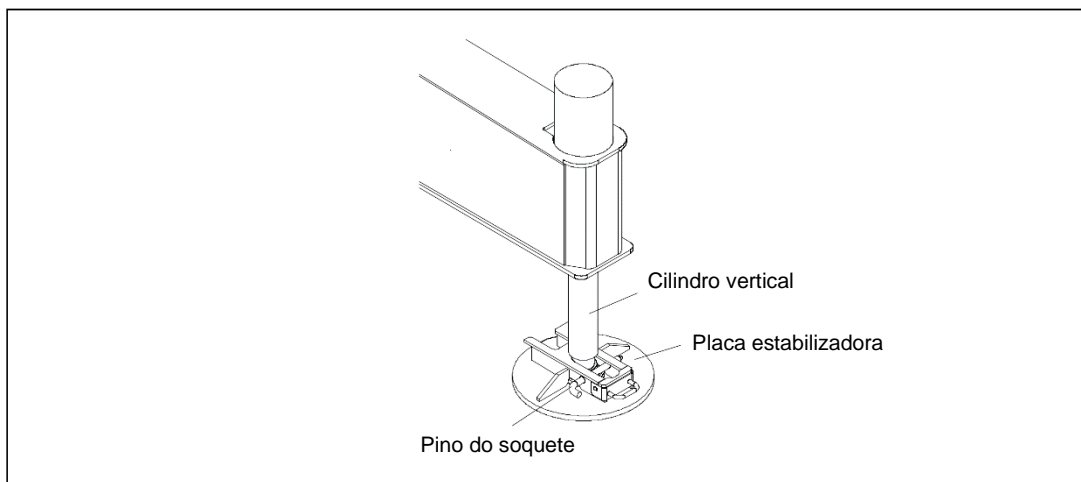
b) Remoção

Após retraindo totalmente os estabilizadores, remova o pino do soquete e empurre a placa estabilizadora até estar na posição correta. Instale os pinos do soquete.



CUIDADO

- (1) **Antes de mover os estabilizadores, verifique se há folga para impedir ferimentos ao pessoal ou danos ao guindaste ou outros objetos.**
- (2) **Certifique-se de instalar as placas estabilizadoras antes de mover os estabilizadores.**
- (3) **Certifique-se que todas as placas estabilizadora (exceto a placa do 5º estabilizador) estão em contato com o solo.**
- (4) **É possível estender o 5º estabilizador apenas até a posição em que a placa de estabilizador estiver aproximadamente 5 - 10 mm do solo. Não é permitido que os dois estabilizadores dianteiros estejam distantes do solo, devido à extensão excessivo do 5º estabilizador.**
- (5) **Certifique-se que todos os pneus estejam fora do solo (peso do guindaste suportado pelos estabilizadores) antes de começar a levantar a carga.**
- (6) **Quando o guindaste estiver em uma área nivelada, verifique o medidor**

de nivelamento. A bolha é mostrada no meio do medidor. Se não, ajuste as porcas abaixo do medidor de nivelamento.



Não opere as alavancas de controle de estabilizador em uma operação de levantamento.

4.5.3 Grua

- a) Coloque o interruptor “pré-seleção de telescópio/grua” na posição correta. Consulte a figura 4-67.



Figura 4-67 Interruptor de “pré-seleção de telescópio/grua”

- b) O joystick direito controla a engrenagem de grua.
- Posição neutra: para o movimentos de grua
 - Mova o joystick para a esquerda (direção ③).

Resultado:

A lança telescópica é elevada.

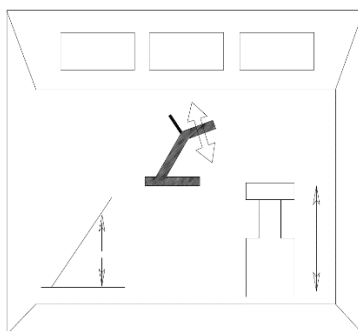
- Mova o joystick para a direita (direção ④).

Resultado:

A lança telescópica é abaixada.

Consulte a figura 4-68.



Figura 4-68 Joystick direito

A velocidade do movimento de elevação é modificada por:

- Joystick direito - a distância que você move o joystick para a esquerda

- Pedal de controle de motor - aumenta ou diminui RPMs de motor.

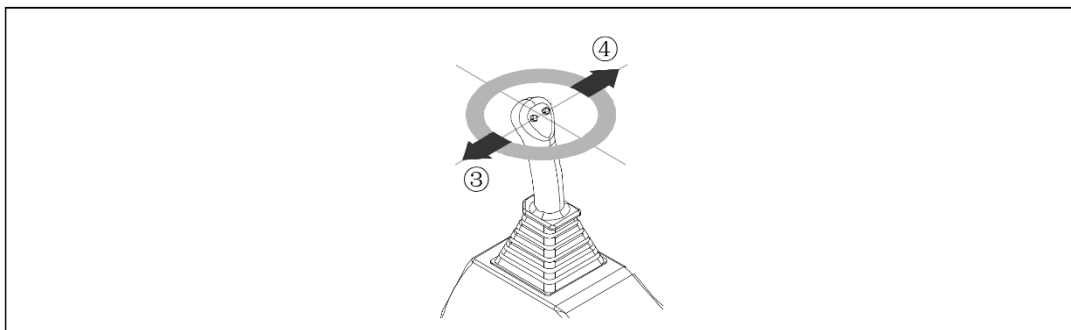
Nota:

Não aplique o pedal de controle de motor quando a distância do percurso da alavanca de controle for curta. Não mude a velocidade de grua rapidamente.

! CUIDADO

A velocidade de movimento de abaixamento não depende da distância de percurso do pedal de controle de motor.

O detector de ângulo se conecta na lateral da lança principal. Consulte a figura 4-69. O detector de ângulo é um dispositivo eletrônico que envia dados de ângulo de lança para o limitador de momento de carga. O ângulo de lança é mostrado na tela de exibição.



Figura 4-69 Dispositivos de segurança na lança principal

! ADVERTÊNCIA

- (1) **Execute todos os movimentos de grua suavemente. É possível causar danos ao guindaste se mover a carga para cima ou baixo, com paradas rápidas.**
- (2) **O ângulo de grua e raio de operação devem estar restritos de acordo com as tabelas de capacidade de levantamento.**

4.5.4 Levantamento/abaixamento

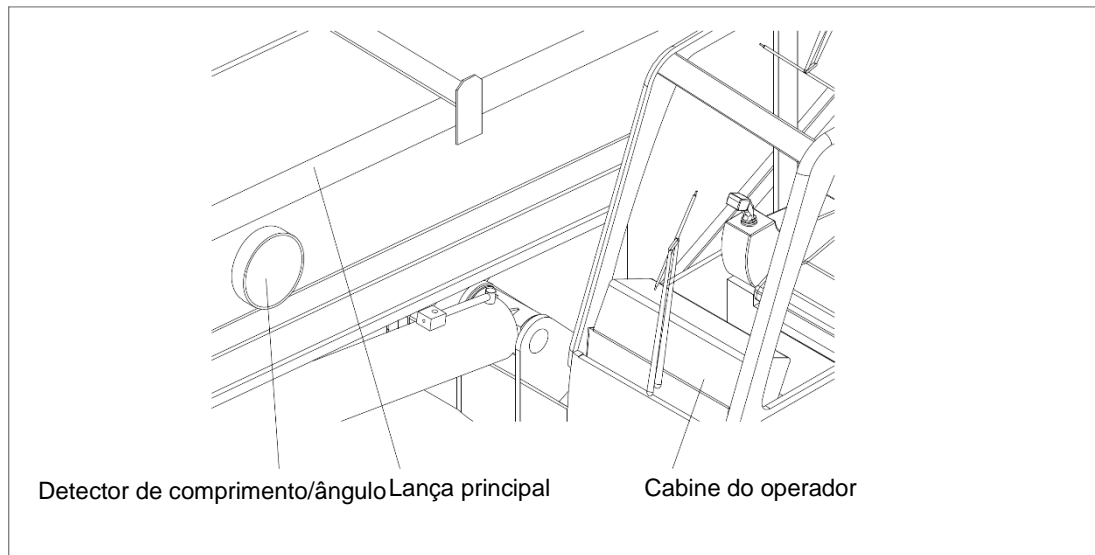
4.5.4.1 Preparações

Leia *Tabelas de capacidade de levantamento e gráfico de altura de levantamento* no capítulo 1 antes da operação de levantamento/abaixamento.

Tabela de capacidade de levantamento (consulte a figura 4-70).

Como consultar a capacidade de levantamento na *Tabela de capacidade de levantamento*:

Consulte o comprimento de lança principal para altura de levantamento e raio de trabalho no gráfico de altura de levantamento.

Consulte a capacidade de levantamento de acordo com o comprimento de lança principal verificado nas tabelas de capacidade de levantamento.

Se o braço estiver instalado, consulte a capacidade de levantamento de acordo com o ângulo de lança na tabela.

Por exemplo:

Se os estabilizadores estiverem totalmente estendidas e a lança principal estiver além dos lados e traseira, pesquisa a capacidade de levantamento:

A capacidade de levantamento nominal, com raio de trabalho de R_2 :

Se o comprimento de lança principal for L_2 ,

a capacidade de levantamento é W_2 kg. A

capacidade de levantamento nominal, com raio de trabalho de R_3 :

Se o comprimento de lança principal for L_3 ,

a capacidade de levantamento é W_3 kg.

Consulte a figura 4-72.



CUIDADO

- (1) **Consulte a capacidade de levantamento correspondente de acordo com as condições reais de trabalho.**
- (2) **Observe as notas mostradas abaixo da tabela de capacidade de levantamento.**



Figura 4-70 Consulta de capacidade de levantamento

**CUIDADO**

Todo o raio de trabalho e altura de levantamento em gráficos de altura de levantamento não incluem o desvio da lança principal e braço.

As capacidades de levantamento são modificadas com o raio de trabalho.

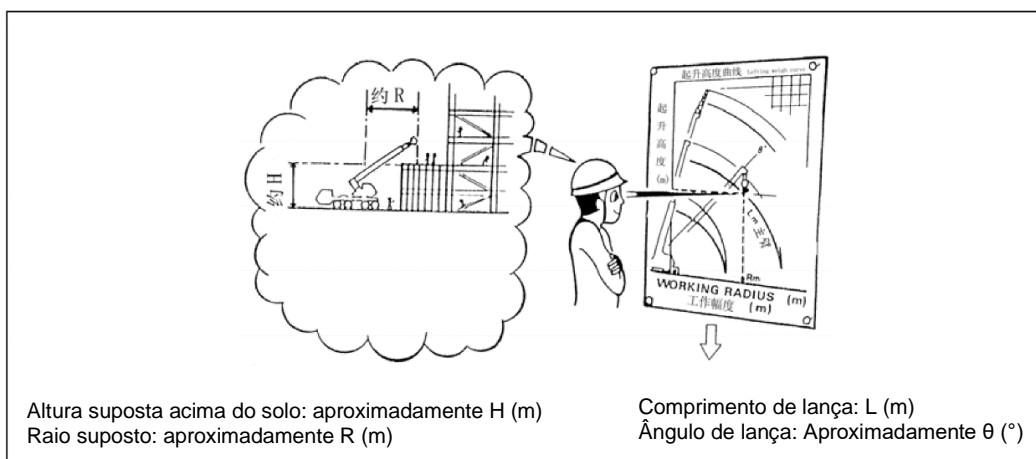

Figura 4-71 Mudança de raio de trabalho

额定起重量表		TABELA DE CAPACIDADE DE LEVANTAMENTO NOMINAL						
工作幅度(m)	主 臂 (m) LANÇA							
	I缸伸至100%，支腿全伸，侧方、后方作业							
RAIO DE TRABALHO (m)	Cilindro I totalmente estendido, com estabilizadores totalmente estendidos, área de trabalho lateral e traseira.							
	L_1	L_2	L_3	L_4	L_5	L_n	
R_1								
R_2								
R_3			W_3					
.....								
R_n								

Nota: L_3 se refere ao comprimento de lança principal. W_3 se refere à capacidade de levantamento nominal.

Figura 4-72 Tabela de capacidade de levantamento nominal

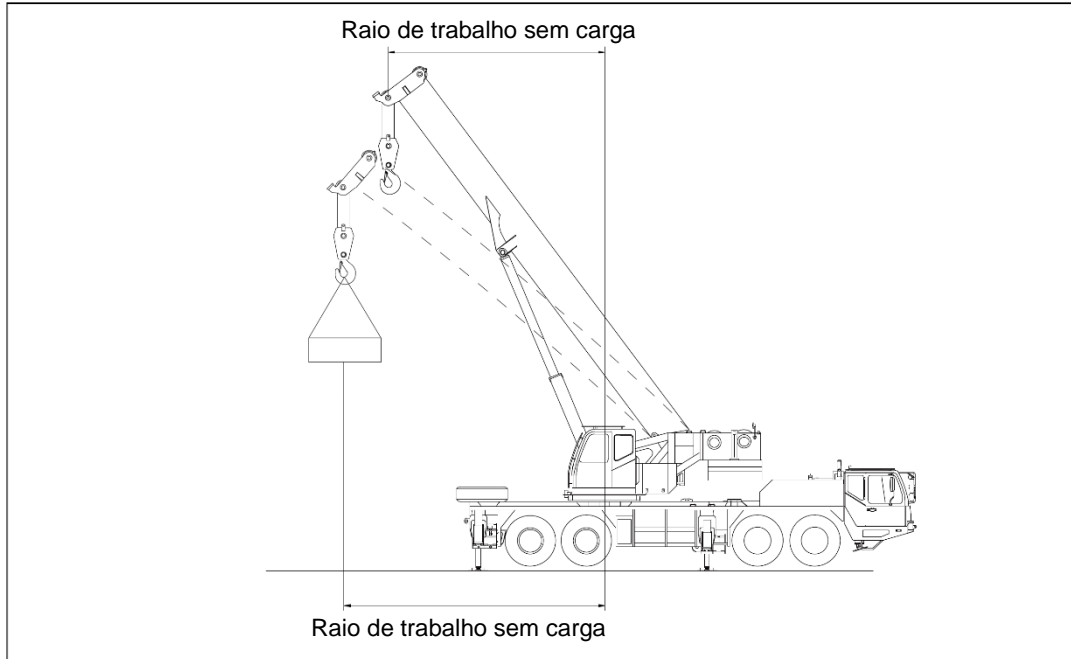
4.5.4.2 Aceleração/bobinamento de guincho principal

- a) O joystick direito controla o guincho principal.
- Posição neutra: parar aceleração/bobinamento do guincho principal
 - Mova o joystick para frente (direção ①).

Resultado:

O guincho principal está bobinado.

- Mova o joystick para trás (direção ②).

Resultado:

O guincho principal é acelerado.

Consulte a figura 4-73.



Figura 4-73 Joystick direito

- b) A engrenagem de elevação principal está funcionando. Consulte a figura 4-74.

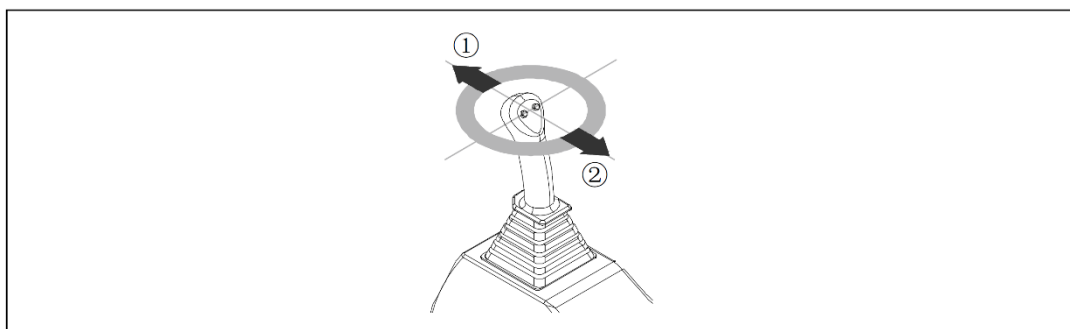

Figura 4-74 Operação de engrenagem de elevação principal

4.5.4.3 Aceleração/bobinamento de guincho auxiliar

- a) O joystick esquerdo controla o guincho auxiliar.
- Posição neutra: parar aceleração/bobinamento do guincho auxiliar.
 - Mova o joystick para frente (direção ①).

Resultado:

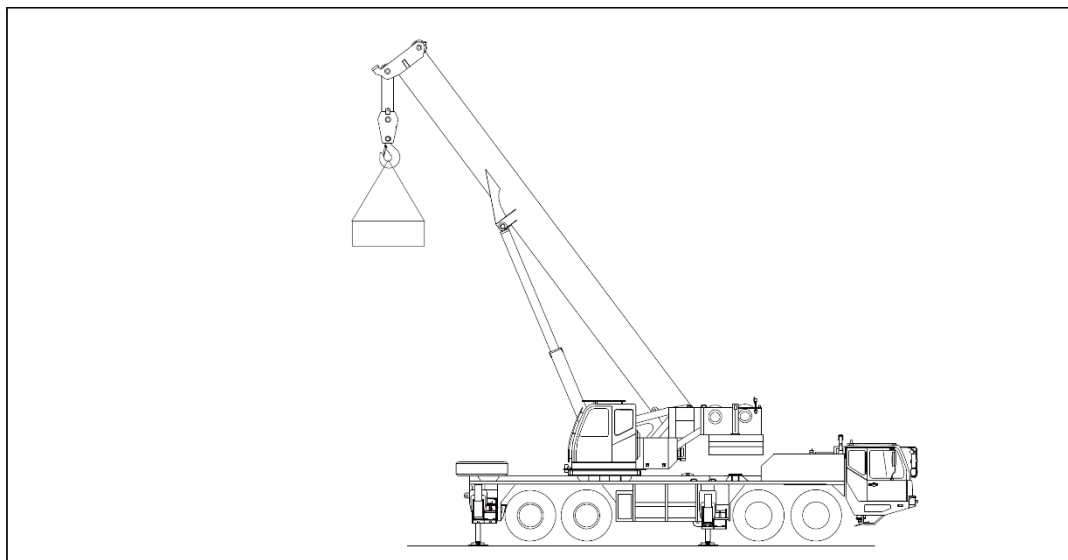
O guincho auxiliar está bobinado.

- Mova o joystick para trás (direção ②).

Resultado:

O guincho auxiliar é acelerado.



Figura 4-75 Joystick esquerdo

- b) A engrenagem de elevação auxiliar está funcionando.

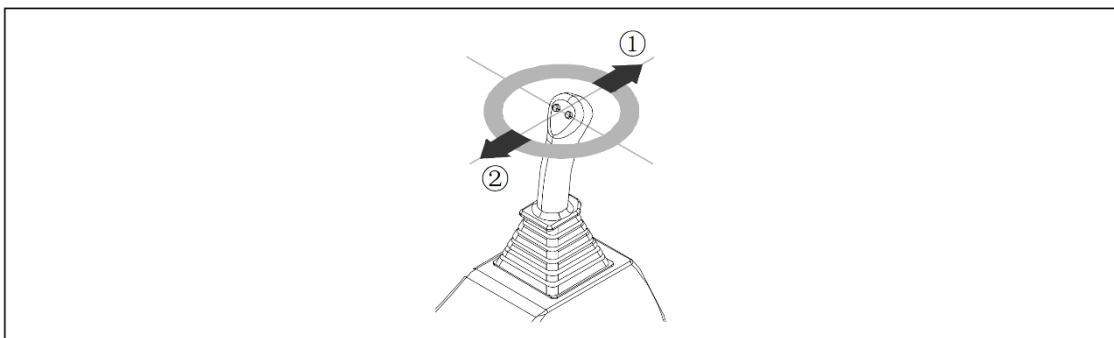

Figura 4-76 Operação de engrenagem de elevação auxiliar

Após completar o movimento, mova o joystick para a posição neutra lentamente para parar os movimentos.

A velocidade de movimento do guincho principal/guincho auxiliar é modificada por:

- Joystick – quanto é movido o joystick para frente ou para trás
- Pedal de controle de motor - aumenta ou diminui RPMs de motor.

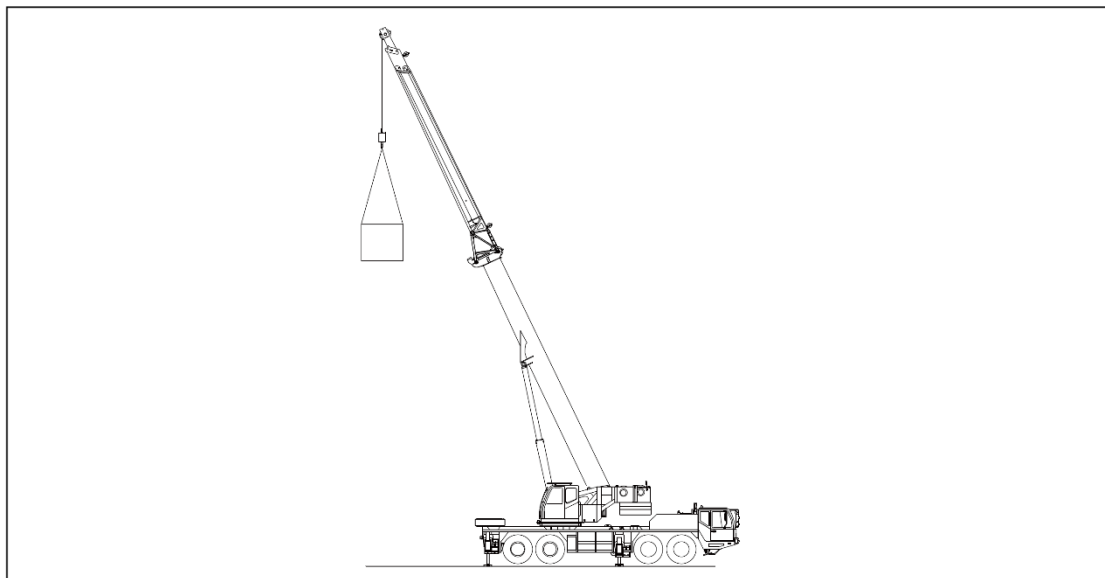
Nota:

Acelere/bobine os guinchos suavemente. É possível causar danos ao guindaste se alterar a velocidade rapidamente.

Não aplique o pedal de controle de motor quando a distância do percurso do joystick for curta. Um som de advertência é ativado e uma luz de advertência acende se os itens abaixo ocorre:

- O guincho principal ou auxiliar está no modo de aceleração e o bloco de gancho toca no peso de interruptor de limite de grua.
- O sensor identifica que o guincho tem 3 enrolamentos de cabo de arame nele.
- O sensor identifica que o peso de carga é superior ao peso da carga no sistema.

Quando ocorrer advertência, a operação do guincho é cortada. O guindaste pode operar apenas em direções seguras até a operação segura ser desativada.



- (1) Escolha a passagem correta para o comprimento de lança e pesos de carga, de acordo com as tabelas de capacidade de levantamento. Antes de modificar os números de passagem, instale o peso do interruptor de fim de curso de elevação.**
- (2) Mantenha pelo menos 3 enrolados de cabo no guincho ao operador o guindaste.**
- (3) Levante a carga verticalmente. Não arraste a carga antes de estar parada no solo. Não coloque a carga em um ângulo.**
- (4) Monitore a área conforme levanta a carga. Não mova a carga a não ser que as condições estejam seguras. Não levanta a lança e a estenda ao mesmo tempo se:**
 - O guindaste tem uma parte do peso da carga.
 - O guindaste se conecta a uma carga no solo.
- (5) Não alterne rapidamente entre “bobinamento” e “aceleração”. Espere o guincho antes de continuar a mover o gancho. Caso contrário, a máquina vai ser danificada gravemente!**
- (6) As eslingas devem ter resistência suficiente. A capacidade de levantamento inclui a massa do gancho e eslingas.**
- (7) Não use o guindaste para levantar o pessoal.**
- (8) Se o gancho virar por causa do cabo, coloque a carga no solo. Não levante a carga até o cabo estar reto.**

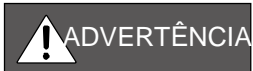

Não faça operação de levantamento com o guincho principal e guincho auxiliar ao mesmo tempo.

4.5.5 Giro

4.5.5.1 Operação

O joystick esquerdo controla a engrenagem de giro.

- Posição neutra: para o movimentos de giro.
- Mova o joystick para a esquerda (direção ④).

Resultado:

Gire para a esquerda .

- Mova o joystick para a direita (direção ③).

Resultado:

Gire para a direita.

Consulte a figura 4-77.

Figura 4-75 Joystick esquerdo

A velocidade do movimento de giro é modificada por:

- Joystick esquerdo - a distância que você move o joystick para a esquerda ou direita
- Pedal de controle de motor - aumenta ou diminui RPM de motor.



Figura 7-77 Operação de giro

Nota:

Não aplique o pedal de controle de motor quando a distância do percurso do joystick for curta.

Execute o movimento de giro suavemente. É possível causar danos ao guindaste se alterar a velocidade rapidamente.

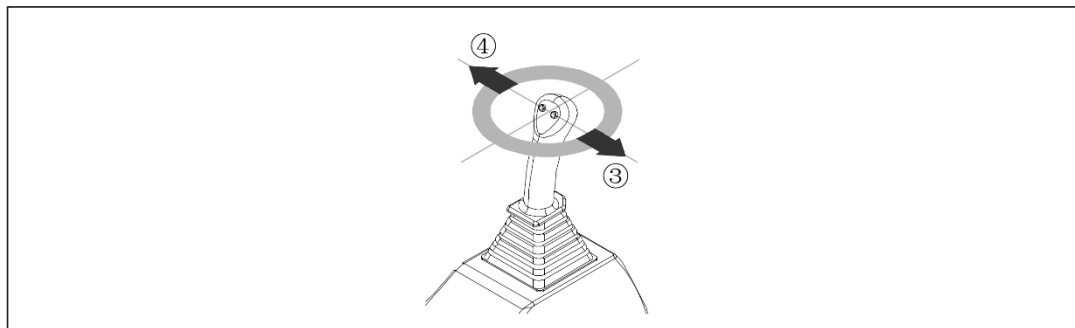

- (1) Durante o giro da superestrutura, o campo de visão do operador se limita. Opere o guindaste com cuidado.
- (2) Verifique se o pessoal e equipamentos do canteiro de obras estão distantes da área de giro do guindaste (dentro do raio de giro R). Emita

um sinal curto de advertência (buzina) antes de iniciar um movimento de guindaste.

- (3) Após o interruptor de confluência ser ativado, não há movimento de giro ao estender o cilindro de telescopagem.

4.5.5.2 Dispositivo de bloqueio de giro

O dispositivo de bloqueio de giro se conecta na frente da mesa de giro. Verifique se os pinos da superestrutura são removidos antes de iniciar o movimento de giro. Insira e fixe o pino após terminar a operação. Consulte a figura 4-78.



Figura 4-78 Dispositivo de bloqueio de giro



- (1) Certifique-se de não fazer movimentos rápidos ou parar o giro repentinamente.
- (2) Ao operar um novo guindaste, certifique-se de examinar os parafusos do mancal de giro nesses intervalos: 100, 500, 1000 horas de operação.
 - O torque nos parafusos deve ser 1350 N·m.
- (3) O guindaste pode girar com a carga. Não tente levantar a carga diagonalmente. Não coloque a carga pelo solo.
- (4) Verifique se os estabilizadores estão na posição correta antes de girar a superestrutura com uma carga na lança.
- (5) Monitore a área conforme move a carga. Não mova a carga a não ser que as condições estejam seguras.
- (6) Lubrifique o mancal de giro em intervalos regulares.

4.5.6 Movimentos simultâneos de guindaste

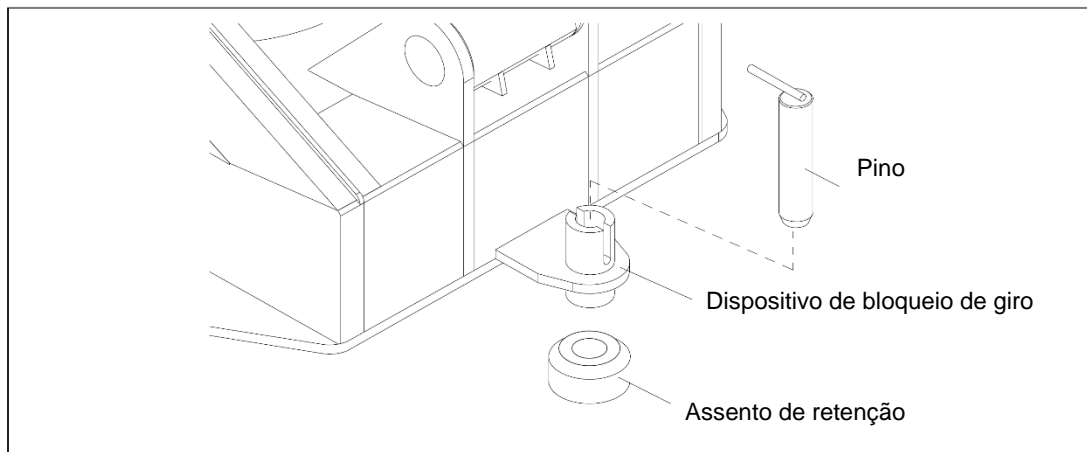
O guindaste pode fazer duas operações ao mesmo tempo. Isso aumenta a quantidade de trabalho que o guindaste pode fazer e aumenta bastante a eficiência de trabalho. Entretanto, uma vez que os movimentos simultâneos de guindaste são de duas direções diferentes, o operador deve tomar o máximo de cuidado para evitar acidentes.

Antes de começar, verifique ou execute os itens a seguir:

- O sistema hidráulico funciona corretamente e oferece vazão suficiente para movimentos simultâneos de guindaste.
- Certifique-se de aumentar os RPMs do motor (ative PTO).
- Não mova os joysticks até suas posições de limite. Movimentos fáceis e suaves são necessários ao fazer uma operação para movimentos simultâneos de guindaste.

Há 9 movimentos simultâneos de guindaste disponíveis:

a) Guincho auxiliar + guincho principal

Para mover o guincho auxiliar e o guincho principal ao mesmo tempo, mova (empurre e/ou puxe) os joysticks esquerdo e direito. O gancho auxiliar e gancho principal se movem para cima e/ou para baixo. Consulte a figura 4-79.

- 1) Quanto mais os joysticks forem desviados para cima ou para baixo, mais rápidos serão os movimentos relacionados.
- 2) Coloque o interruptor “pré-seleção de velocidade normal/baixa/extremamente baixa!” na posição neutra ou direita, para fazer com que os movimentos relevantes sejam mais lentos.



Figura 4-79 Guincho auxiliar + guincho principal

b) Guincho auxiliar + grua

É possível mover o gancho auxiliar para cima ou para baixo e levantar ou abaixar a lança ao mesmo tempo. Para fazer isso, empurre ou puxe o joystick esquerdo e mova o joystick direito para a esquerda ou direita. Consulte a figura 4-80.

- 1) Coloque o interruptor de “pré-seleção de grua/telescópio” (no painel de controle direito) na posição esquerda.
- 2) Quanto mais o joystick esquerdo for desviado para cima ou para baixo e o joystick direito for desviado para a esquerda ou direita, mais rápidos serão os

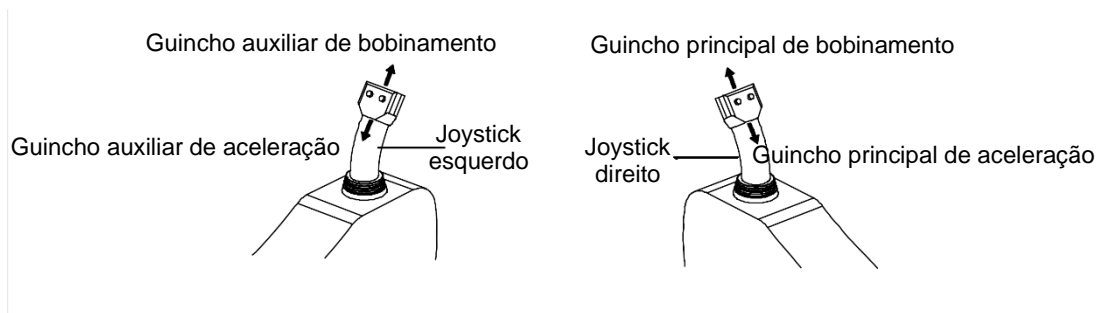
movimentos relevantes.

- 3) Coloque o interruptor “pré-seleção de velocidade normal/baixa/extremamente baixa!” na posição neutra ou direita, para fazer com que os movimentos relevantes sejam mais lentos.



Figura 4-80 Guincho auxiliar + grua

- c) Guincho auxiliar + telescópio

É possível mover o gancho auxiliar para cima ou para baixo e executar telescopagem de lança para fora/dentro ao mesmo tempo. Para fazer isso, empurre ou puxe o joystick esquerdo e mova o joystick direito para a esquerda ou direita. Consulte a figura 4-81.

- 1) Coloque o interruptor de “pré-seleção de grua/telescópio” (no painel de interruptor direito) na posição direita.
- 2) Quanto mais o joystick esquerdo for desviado para cima ou para baixo e o joystick direito for desviado para a esquerda ou direita, mais rápidos serão os movimentos relevantes.
- 3) Coloque o interruptor “pré-seleção de velocidade normal/baixa/extremamente baixa” na posição neutra ou direita, para fazer com que os movimentos relevantes sejam mais lentos.

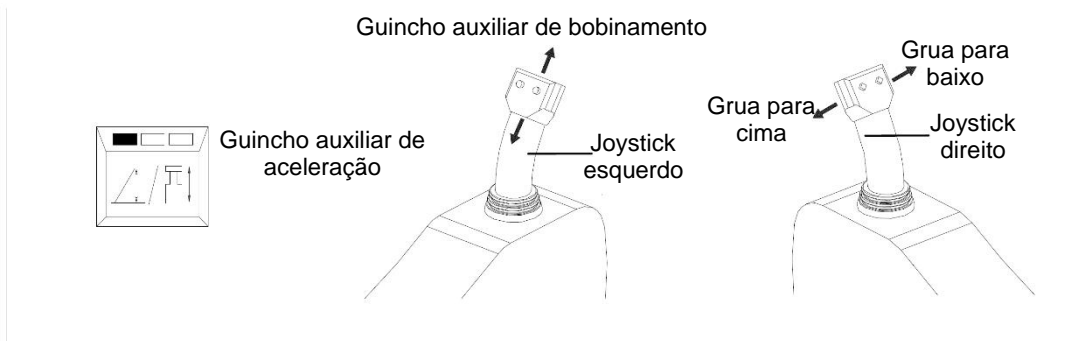
Nota:

Ao selecionar o modo de telescopagem automática, o joystick direito e o interruptor de “pré-seleção de velocidade normal/baixa/extremamente baixa” são inválidos.



Figura 4-81 Guincho auxiliar + telescópio



É altamente recomendado selecionar o modo de telescopagem automática para operação de telescopagem.

d) Giro + guincho principal

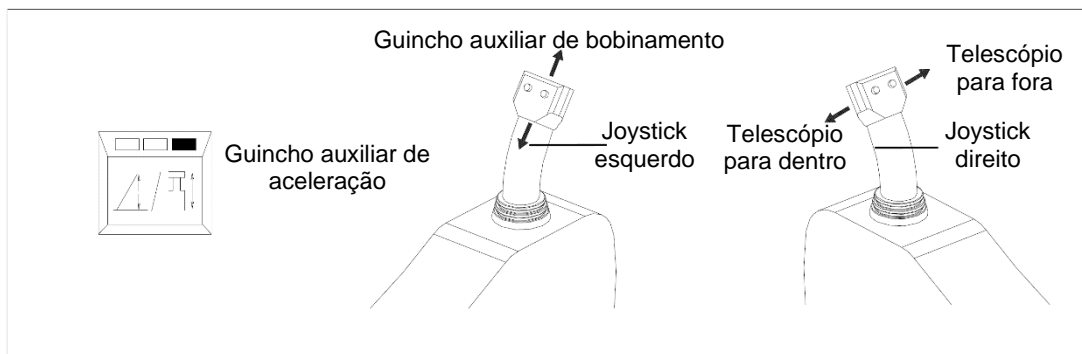
É possível girar para a esquerda e mover o gancho principal para cima ou para baixo ao mesmo tempo. Para fazer isso, mova o joystick esquerdo ou direito e empurre ou puxe o joystick direito. Consulte a figura 4-82.

- 1) Quanto mais o joystick esquerdo for desviado para esquerda ou direita e o joystick direito for desviado para cima ou para baixo, mais rápidos serão os movimentos relevantes.
- 2) Coloque o interruptor “pré-seleção de velocidade normal/baixa/extremamente baixa” na posição neutra ou direita, para fazer com que os movimentos relevantes sejam mais lentos.



Figura 4-82 Giro + guincho principal

e) Giro + telescópio

É possível girar para a esquerda ou direita e executar telescopagem da lança para fora/dentro ao mesmo tempo. Para fazer isso, mova os joysticks esquerdo e direito para a esquerda ou direita. Consulte a figura 4-83.

- 1) Coloque o interruptor de “pré-seleção de grua/telescópio” (no painel de interruptor direito) na posição direita.
- 2) Quanto mais o joystick esquerdo/direito for desviado para a esquerda ou direita, mais rápidos serão os movimentos relevantes.
- 3) Coloque o interruptor “pré-seleção de velocidade normal/baixa/extremamente baixa” na posição neutra ou direita, para fazer com que os movimentos relevantes sejam mais lentos.

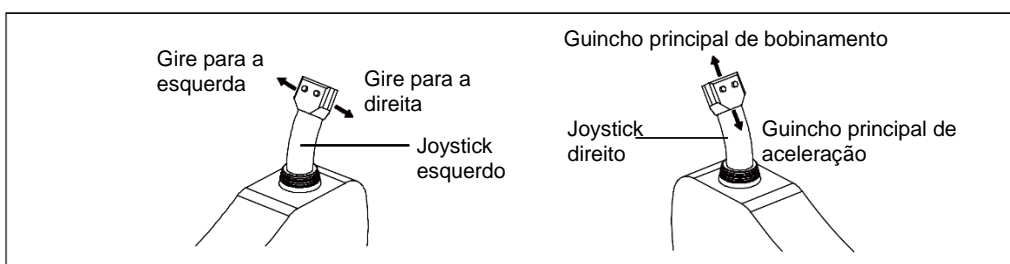
Nota:

Ao selecionar o modo de telescopagem automática, o joystick direito e o interruptor de “pré-seleção de velocidade normal/baixa/extremamente baixa” são inválidos.



Figura 4-83 Giro + telescópio

**CUIDADO**

É altamente recomendado selecionar o modo de telescopagem automática e desativar o interruptor de confluência para operação de telescopagem.

f) Giro + grua

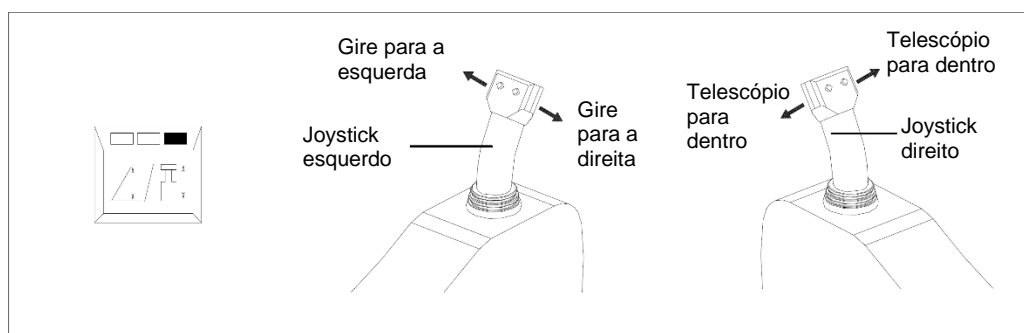
É possível girar para a esquerda ou direita e executar elevar/abaixar a lança ao mesmo tempo. Para fazer isso, mova os joysticks esquerdo e direito para a esquerda ou direita. Consulte a figura 4-84.

- 1) Coloque o interruptor de “pré-seleção de grua/telescópio” (na caixa de controle esquerda) na posição esquerda.
- 2) Quanto mais o joystick esquerdo/direito for desviado para a esquerda ou direita, mais rápidos serão os movimentos relevantes.
- 3) Coloque o interruptor “pré-seleção de velocidade normal/baixa/extremamente baixa” na posição neutra ou direita, para executar os movimentos relevantes



Figura 4-84 Giro + Grua

g) Giro + guincho auxiliar

É possível girar para a esquerda e mover o gancho auxiliar para cima ou para baixo ao mesmo tempo. Para esse tipo de movimento, é necessário que o operador mova o joystick esquerdo duas direções adjacentes. Por exemplo, para mover a mesa de giro para a direita e mover o gancho auxiliar para baixo, empurre o joystick esquerdo para cima e para a direita (posição 1:30 no relógio). Consulte a figura 4-85.

Os outros movimentos no joystick esquerdo são os seguintes: (Consulte a figura 4-85.)

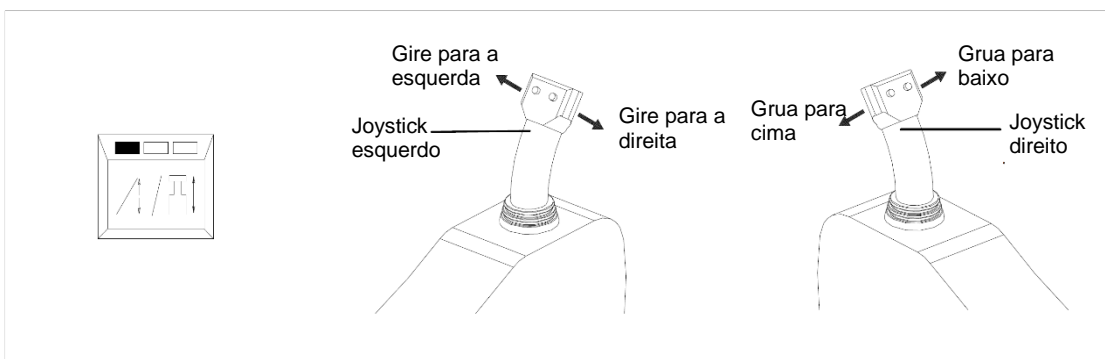
- 1) Empurre para cima e para a esquerda (posição 10:30 no relógio) - a mesa de giro se move para a esquerda e o gancho auxiliar move para baixo.
- 2) Empurre para trás e para a direita (posição 4:30 no relógio) – a mesa de giro se move para a direita e o gancho auxiliar move para cima.
- 3) Empurre para trás e para a esquerda (posição 07:30 no relógio) – a mesa de giro se move para a esquerda e o gancho auxiliar move para cima.
- 4) Quanto mais o joystick for desviado para a esquerda ou direita, mais rápidos

os movimentos de giro ficam e mais lentos os movimentos do guincho.

- 5) Quanto mais o joystick for desviado para cima e para baixo, mais rápidos os movimentos do guincho ficam e mais lentos os movimentos do giro.
- 6) Coloque o interruptor “pré-seleção de velocidade normal/baixa/extremamente baixa” na posição neutra ou direita, para executar os movimentos relevantes



Figura 4-85 Giro + guincho principal

h) Guincho principal + grua

É possível levantar/abaixar a lança e mover o gancho principal para cima ou para baixo ao mesmo tempo. Para esse tipo de movimento, é necessário que o operador mova o joystick direito duas direções adjacentes. Por exemplo, para mover a lança para baixo e o gancho principal para baixo, empurre o joystick direito para cima e para a direita (posição 1:30 no relógio). Consulte a figura 4-86. Os outros movimentos no joystick direito são os seguintes:

Empurre para cima e para a esquerda (posição 10:30 no relógio) – a lança se move para cima e o gancho principal move para baixo.

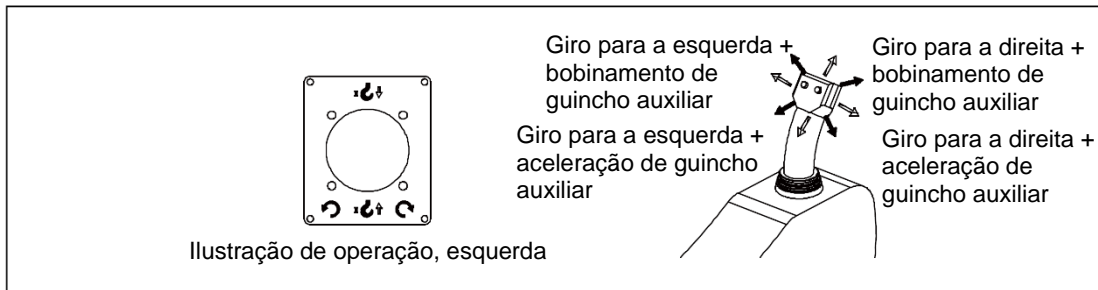
Empurre para trás e para a direita (posição 4:30 no relógio) – a lança se move para baixo e o gancho principal move para cima.

Empurre para trás e para a esquerda (posição 07:30 no relógio) – a lança se move para cima e o gancho principal move para cima.

- 1) Coloque o interruptor de “pré-seleção de grua/telescópio” na posição esquerda.
- 2) Quanto mais o joystick for desviado para a esquerda ou direita, mais rápidos os movimentos de grua ficam e mais lentos os movimentos do guincho.
- 3) Quanto mais o joystick for desviado para cima e para baixo, mais rápidos os movimentos do guincho ficam e mais lentos os movimentos de grua.
- 4) Coloque o interruptor “pré-seleção de velocidade normal/baixa/extremamente baixa” na posição neutra ou direita, para fazer com que os movimentos relevantes sejam mais lentos.



Figura 4-86 Guincho principal + grua

i) Guincho principal + telescópio

É possível executar telescopagem da lança principal para dentro/fora e mover o gancho principal para cima ou para baixo ao mesmo tempo. Para esse tipo de movimento, é necessário que o operador mova o joystick direito duas direções adjacentes. Por exemplo, para mover o gancho principal para baixo e o telescópio para fora, empurre o joystick direito para cima e para a direita (posição 1:30 no relógio). Consulte a figura 4-87. Os outros movimentos no joystick direito são os seguintes:

Empurre para cima e para a esquerda (posição 10:30 no relógio) – a lança executa telescopagem para dentro e o gancho principal move para baixo.

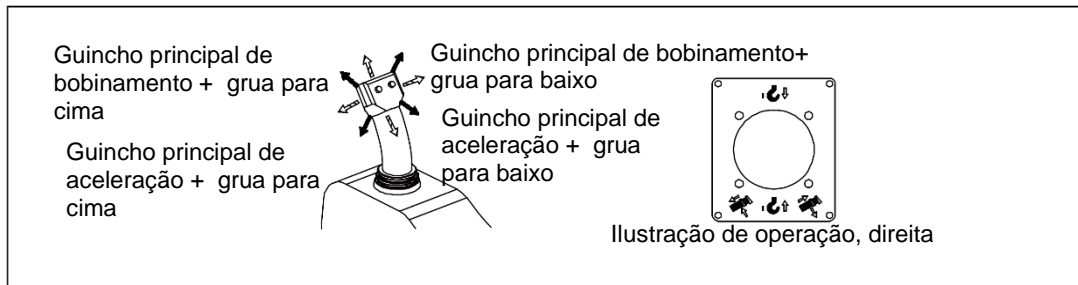
Empurre para trás e para a direita (posição 4:30 no relógio) – a lança executa telescopagem para fora e o gancho principal move para cima.

Empurre para trás e para a esquerda (posição 07:30 no relógio) – o telescópio se move para dentro e o gancho principal move para cima.

- 1) Coloque o interruptor de “pré-seleção de grua/telescópio” na posição direita.
- 2) Quanto mais o joystick for desviado para a esquerda ou direita, mais rápidos os movimentos de telescopagem ficam e mais lentos os movimentos do guincho.
- 3) Quanto mais o joystick for desviado para cima e para baixo, mais rápidos os movimentos do guincho ficam e mais lentos os movimentos de telescopagem.
- 4) Coloque o interruptor “pré-seleção de velocidade normal/baixa/extremamente baixa” na posição neutra ou direita, para fazer com que os movimentos relevantes sejam mais lentos.

Nota:

Ao selecionar o modo de telescopagem automática, o joystick direito e o interruptor de “pré-seleção de velocidade normal/baixa/extremamente baixa” são inválidos.



Figura 4-87 Guincho principal + telescópio



ADVERTÊNCIA

Realize movimentos simultâneos de guindaste sem pegar uma carga ou com uma carga suspensa. Não realize telescopagem da lança com uma carga suspensa.

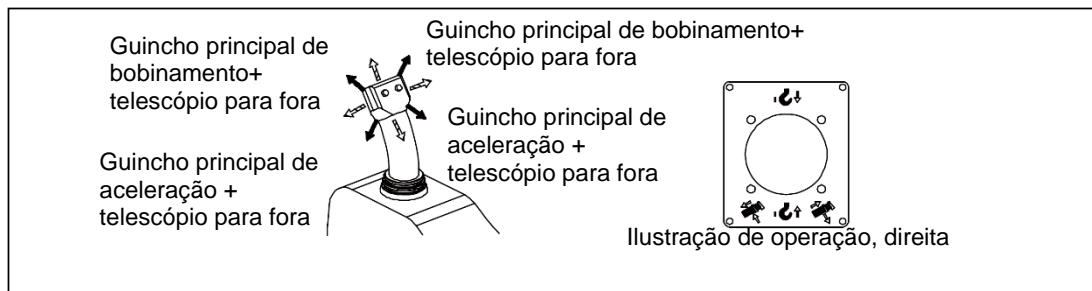
4.5.7 Passagem de cabo

Antes de iniciar a modificar as passagens de cabo de arame:

- Suporte o guindaste em estabilizadores.
- Retraia totalmente a lança e mova para o lado ou para trás do guindaste. Consulte a figura 4-88.



Figura 4-88 Passagem de cabo

Modifique as passagens de cabo de arame como segue:

- a) Abaixar a lança e colocar o gancho (a) no solo.
- b) Remover os pinos (b) no bloco de gancho e cabeça de lança, para deixar soltar o cabo de arame.
- c) Remover o peso do interruptor de fim de curso de elevação (c).
- d) Remover o conjunto de calço e soquete (Beckett).
- e) Fazer amarração do cabo no bloco do gancho, para um número de passagem ímpar e na cabeça da lança,

para um número de passagem par.

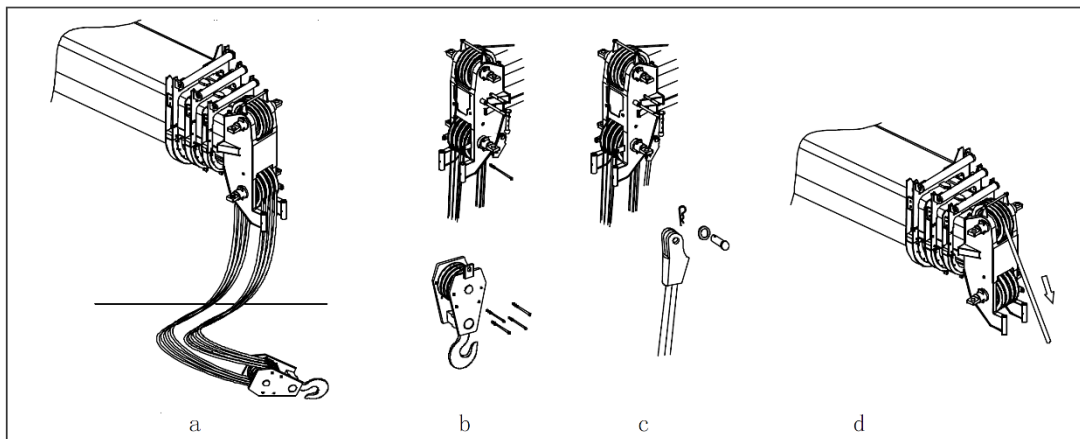
- f) Troca as passagens de cabo (d).



- (1) É necessário trocar o local do peso do interruptor de fim de curso de elevação, se tiver um número diferente de passagens de cabo de arame. Consulte a figura 4-89.



Figura 4-89 Localização do peso do interruptor de fim de curso de elevação

- (2) Coloque o cabo de arame na bobina do guincho suavemente e em sequência.
- (3) Para métodos de instalação de soquete e fixação de cabo, consulte a figura 4-90.

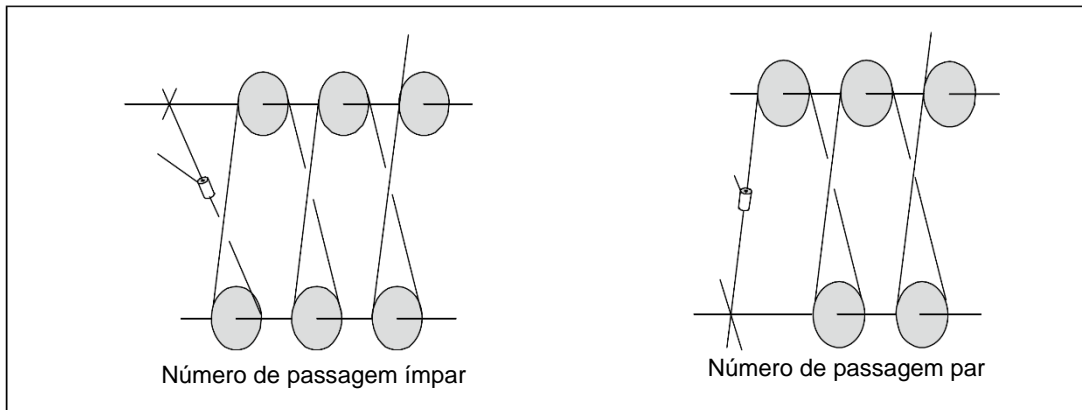

Figura 4-90 Instalação de fixação de cabo

.

ZOOMLION

Manual do operador de caminhão guindaste

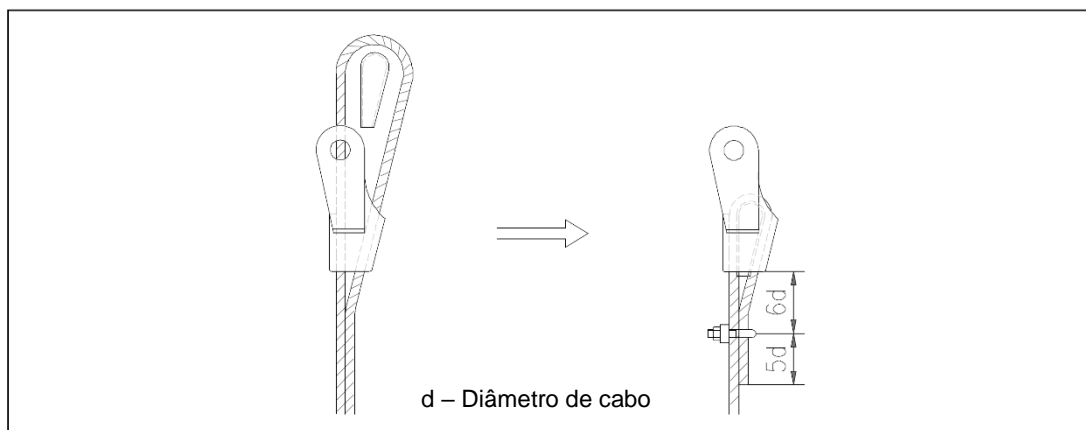
Capítulo 5 Equipamentos



Capítulo 5 Equipamentos

5.1 Diretrizes técnicas de segurança para montagem

- a) Passe o cabo de elevação entre a polia do cabo na cabeça da lança e polia do gancho, de acordo com as passagens correspondentes especificadas em tabelas de capacidade de levantamento.
- b) Monte as placas de contrapeso de acordo com as tabelas de capacidade de levantamento.
- c) Se o braço não estiver em contato com o solo durante a montagem e desmontagem, coloque materiais apropriados e estáveis abaixo do braço.



- (1) Execute o trabalho de montagem com auxílios adequados (andaimes ou plataformas de levantamento, etc.)! Se isso não for observado, o pessoal pode cair e sofrer ferimentos fatais.**
 - (2) Não se posicione abaixo da lança, especialmente quando os pinos do braço estiverem sendo colocados ou retirados.**
- d) Realize inspeções de medição de segurança antes de apoiar o guindaste.
 - e) Antes de configurar e retirar o braço, verifique se os pré-requisitos a seguir são atendidos:
 - 1) O guindaste está suportado e nivelado adequadamente.
 - 2) A lança telescópica está totalmente telescopada para dentro.
 - 3) O braço foi instalado de acordo com as tabelas de capacidade de levantamento.
 - 4) Todas as conexões de pinos foram fixadas.
 - 5) Todos os interruptores de fim de curso foram instalados corretamente e estão totalmente operacionais.
 - 6) O cabo de guincho foi colocado corretamente nas polias de cabo, com os tubos de fixação de cabo, para impedir que solte.
 - 7) Não há peças soltas na lança e braço.



- (1) No inverno, a lança, braço e componentes associados (interruptores de fim de curso, tambores de cabo, luz marcadora de canto, anemômetro, etc.) devem ser mantidos sem neve e gelo.**
- (2) Interruptores de fim de curso instalados incorretamente ou com falha e quedas de peças (pinos, pinos de segurança carregados com mola, gelo, etc.) podem causar ferimentos!**

5.2 Braço

5.2.1 Geral

O braço é um dos componentes mais importantes do caminhão guindaste. Com o braço montado, a carga pode ser levantada até uma altura mais alta e o raio de trabalho pode ser aumentado via deslocamento modificado.

O guindaste tem um braço de 2 seções. Uma seção de braço é de estrutura de treliça quadrangular, enquanto a outra é de estrutura de treliça triangular. Durante a condução, a seção de braço 2 é fixado na seção de braço 1 via pinos e todo o braço está instalado no lado direito da lança principal via pinos. Enquanto isso, a seção de braço 2 também pode ser fixada no lado direito da lança principal individualmente.

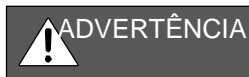

Não é possível utilizar o braço ao levantar uma carga se os estabilizadores não estiverem na posição correta.

5.2.2 Montagem

É possível montar o braço em um ângulo de 0°, 15° ou 30° na lança telescópica, de acordo com os requisitos de trabalho.

Monte o braço (considere deslocamento 0°, por exemplo). Consulte as figuras 5-1 a 5-13.

- a) Estenda os estabilizadores e nivele o guindaste com o medidor de nível.
- b) Retraia a lança totalmente.
- c) Mova a lança para o lado ou traseira do guindaste e posicione a -2°.
- d) Verifique se há raio de giro de 30 m.



Figura 5-1 Conjunto de braço

- a) Ajuste a placa de lingueta no lado esquerdo da cabeça da lança principal e faça com que mantenha uma folga de 1-2 m com o bloco de mancal.

Consulte a figura 5-2.

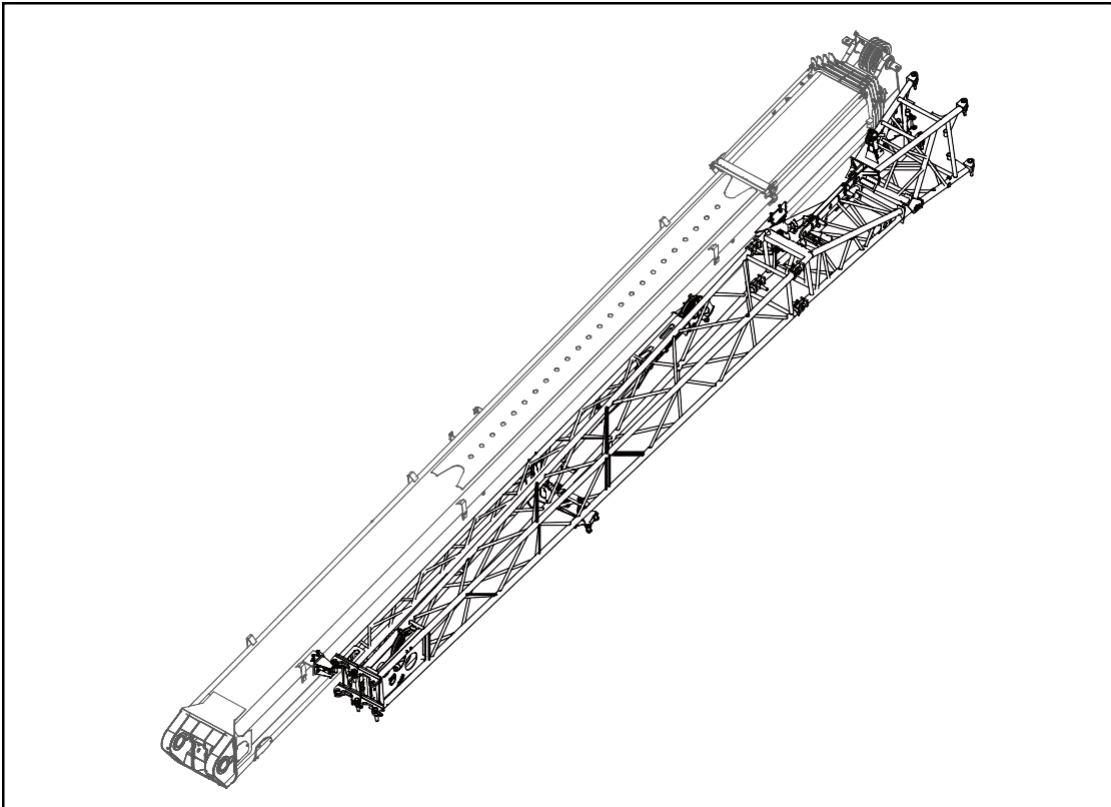

Figura 5-2 Posição de placa de lingueta

- b) Remova o pino I. Estenda o suporte intermediário e instala o pino I removido.
Consulte a figura 5-3.

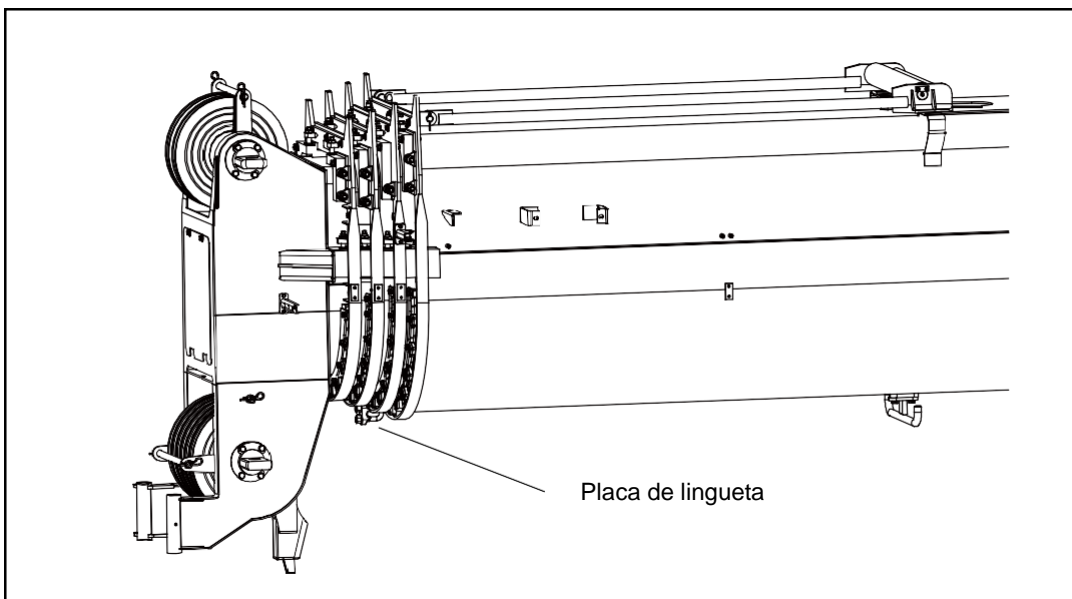

Figura 5-3 Extensão do suporte intermediário

- c) Remova os pinos I e II. Consulte a figura 5-4.

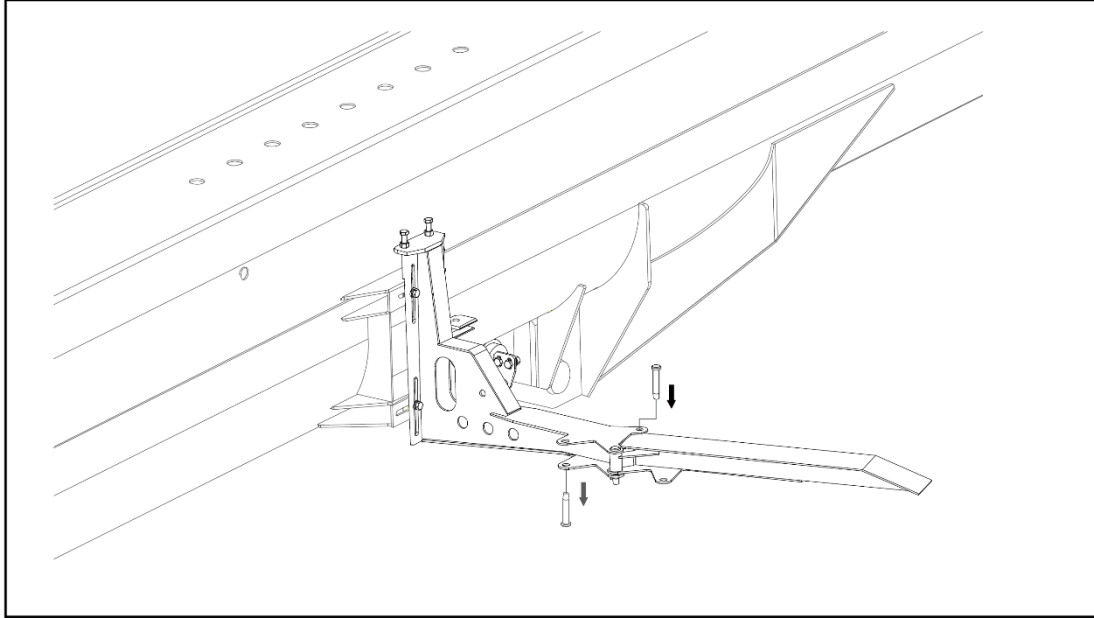

Figura 5-4 Remoção dos pinos I e II

- d) Remova o pino III. Consulte a figura 5-5.

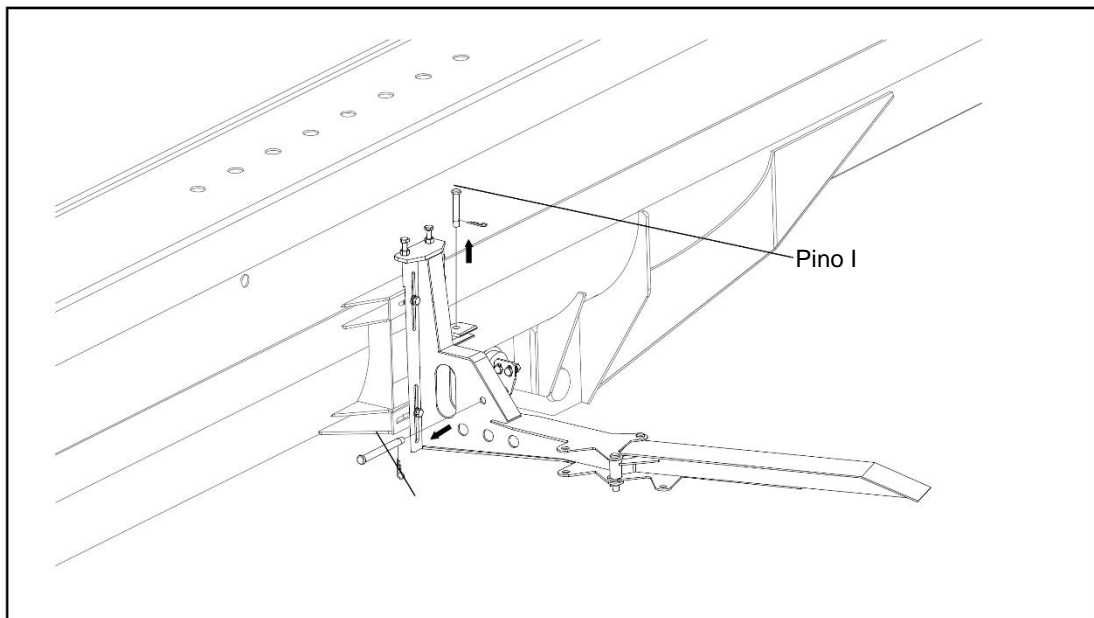

Figura 5-5 Remoção do pino III

- e) Separa da frente do braço da lança principal (pivôs do braço no pino IV). Consulte a figura 5-6.

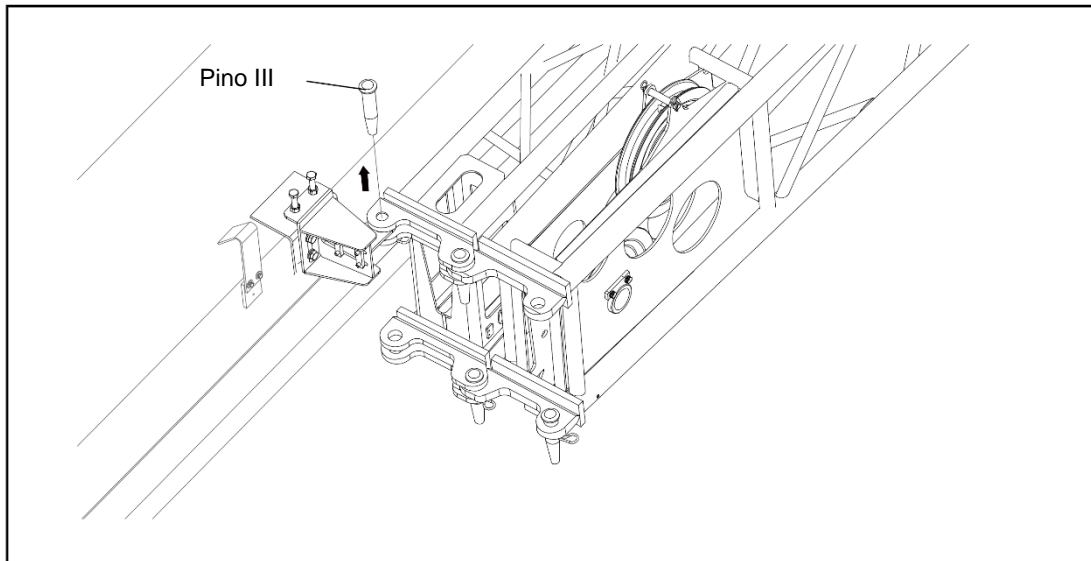

Figura 5-6 Separe a frente do braço da lança principal

- f) Alinhe a extremidade do braço com os pontos de conexão no lado direito da cabeça da lança principal. Instale o pino V e grampo de retenção. Consulte a figura 5-7.

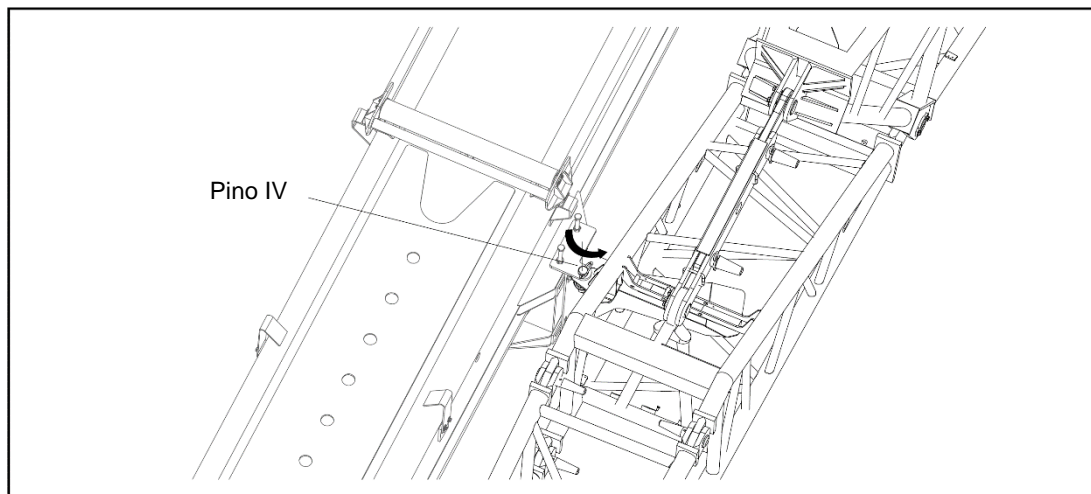

Figura 5-7 Instalação do pino V

- g) Remova o pino IV. Consulte a figura 5-8.

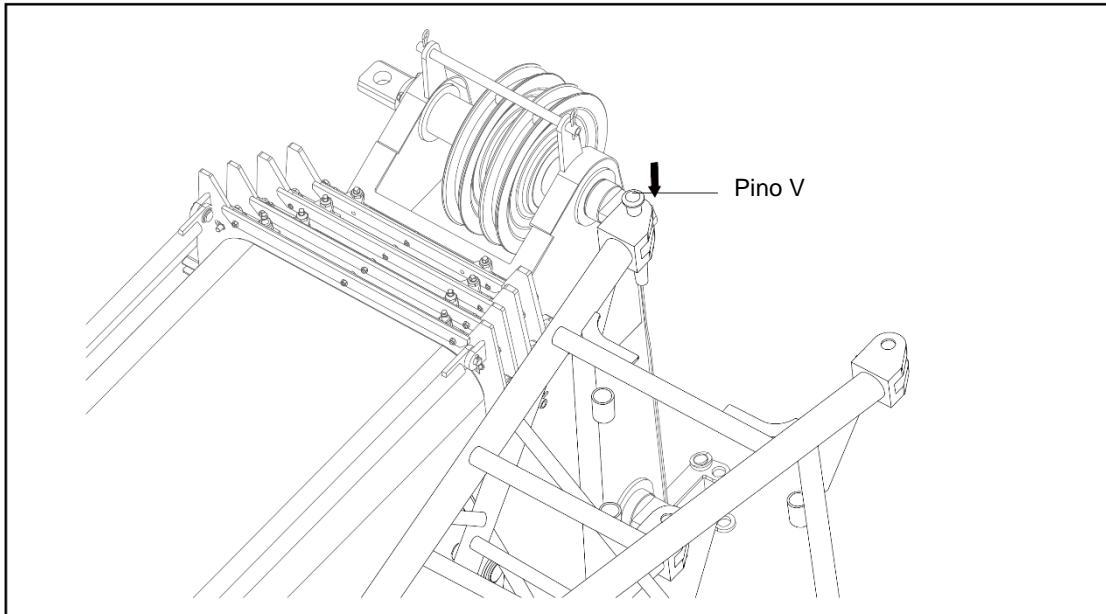

Figura 5-8 Remoção do pino IV

- h) Mova o braço (pivôs no pino IV) na frente da lança principal. Consulte a figura 5-9.

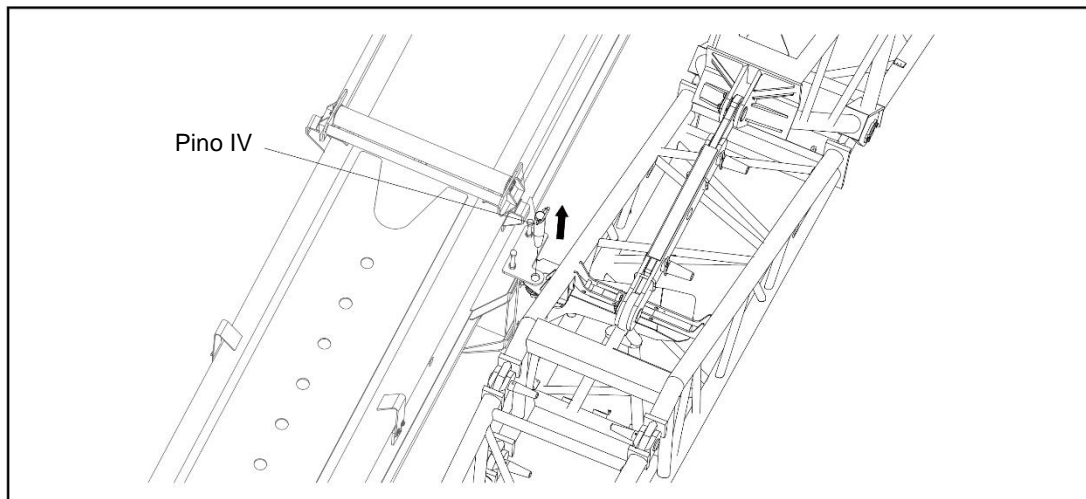

Figura 5-9 Rotação de braço

- i) Alinhe a extremidade do braço com os pontos de conexão no lado esquerdo da cabeça da lança principal. Instale o pino VI e grampo de retenção. Consulte a figura 5-10.

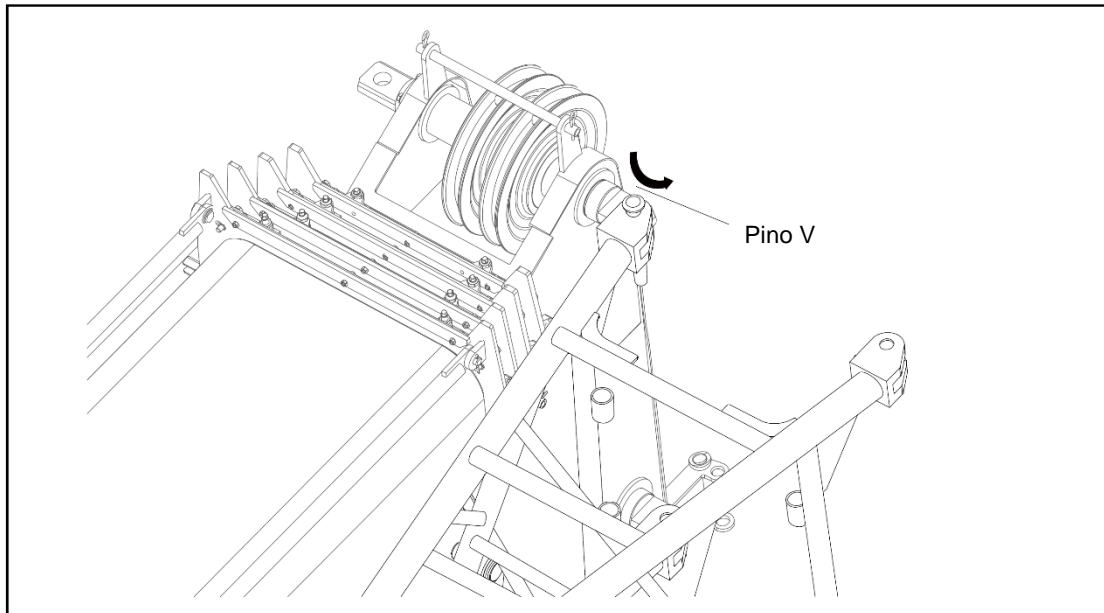

Figura 5-10 Instalação do pino VI

- j) Se a seção do braço II for utilizada, remova o pino VII e o grampo de retenção β , conectando a seção de braço I na seção II. Consulte a figura 5-11.

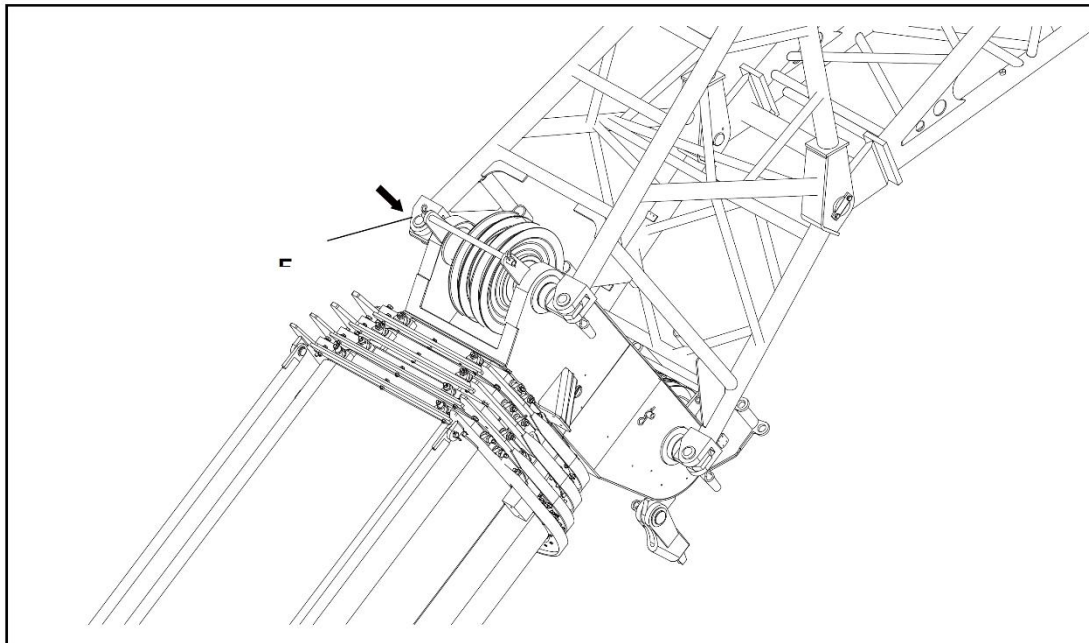

Figura 5-11 Remoção do pino VII

- k) A seção do braço w gira do pino VII até a seção de braço 1 logo à frente. Consulte a figura 5-12.

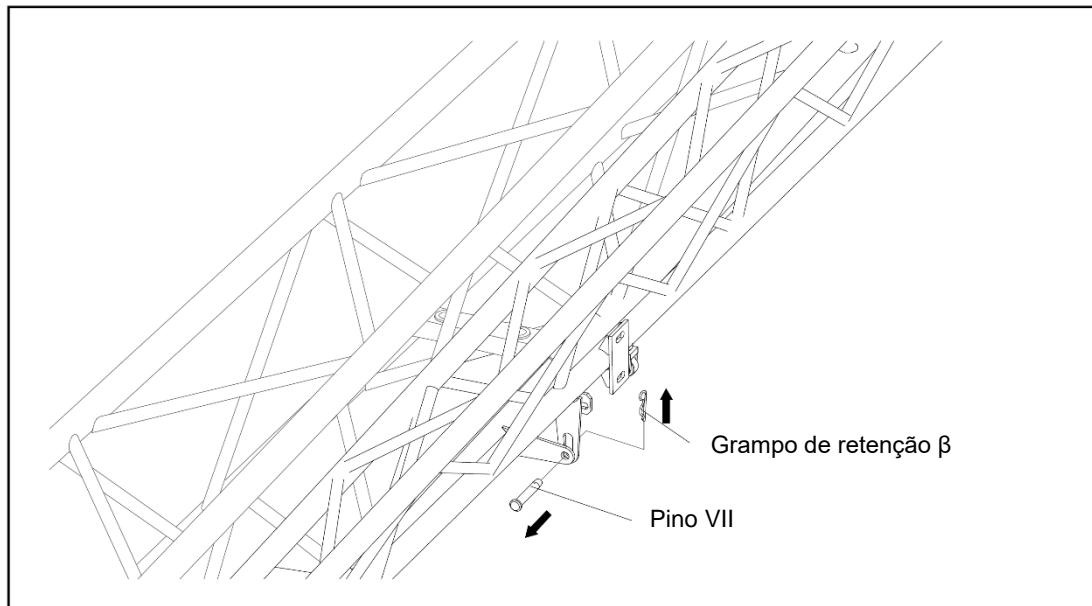

Figura 5-12 Rotação de seção de braço 2

- l) Alinhe a extremidade de seção de braço 2 com os pontos de conexão no lado esquerdo da cabeça da seção de braço 1. Instale o pino IX e grampo de retenção. Consulte a figura 5-13.

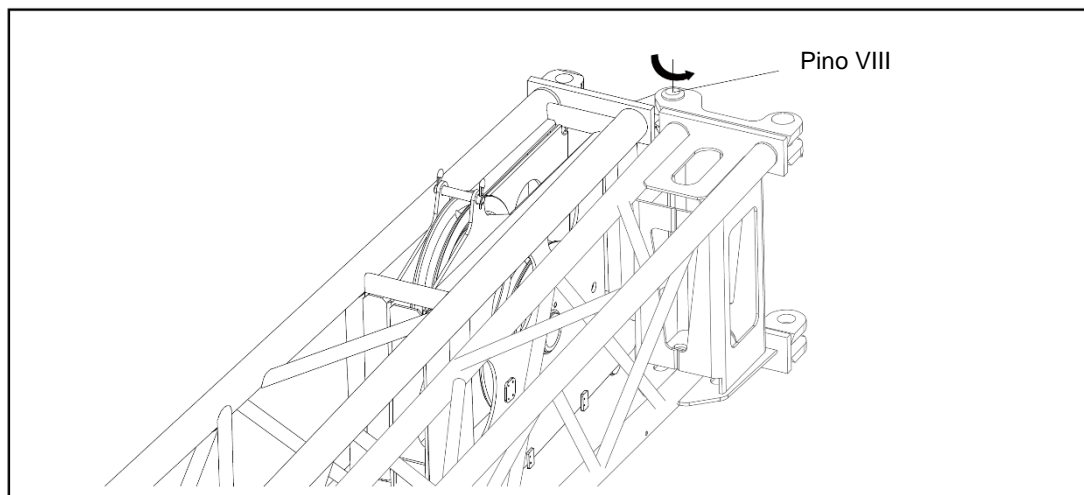

Figura 5-13 Instalação do pino IX

- m) Passe o cabo de arame do guincho auxiliar através da extremidade do braço. Instale o gancho auxiliar e o interruptor de fim de curso de elevação.

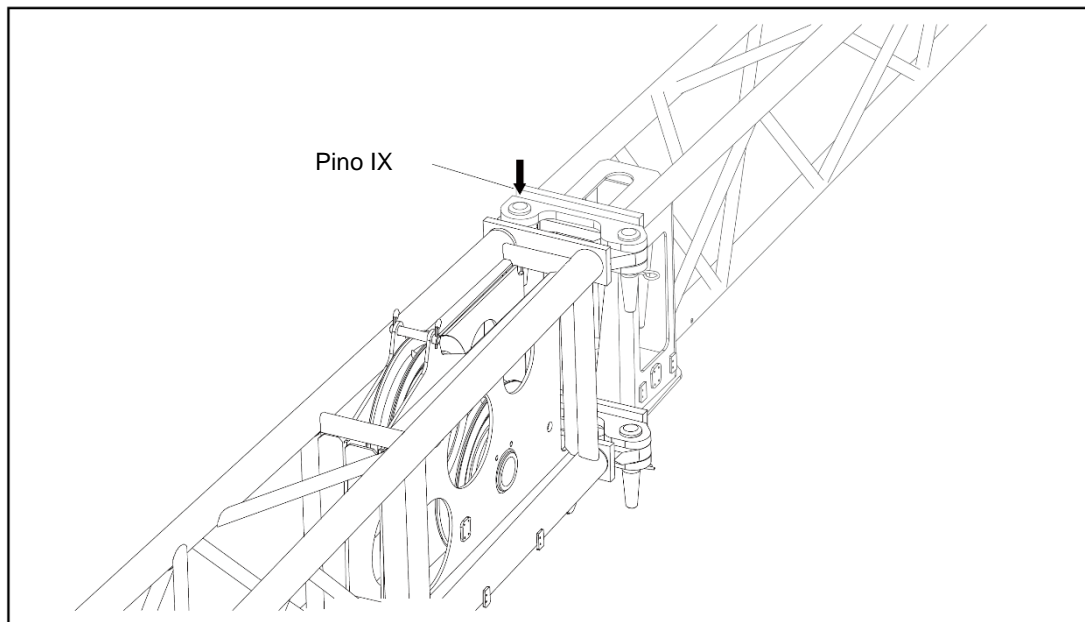

Não se posicione sob o braço durante a operação de giro!

O braço e outros componentes - devido a um erro de montagem - pode cair e causar ferimentos fatais.

5.2.3 Ajustes de ângulo

Troque o deslocamento de braço de 0° a 30°. Consulte a figura 5-14.

- Retire o gancho auxiliar do seu suporte.
- Arrie o cabo de elevação auxiliar para 2 m a 3 m em velocidade lenta.
- Remova os pinos e grampos de retenção do suporte de empuxo do adaptador na extremidade do braço.
- Levante a lança lentamente até a ranhura longa do suporte de empuxo se alinhar com os furos do pino por 30°.
- Coloque os pinos e grampos de retenção no ponto para a posição de 30°.



Figura 5-14 Posições de deslocamento

5.2.4 Desmontagem

Após completar a operação do braço, desmonte-o em ordem inversa aos passos de montagem.

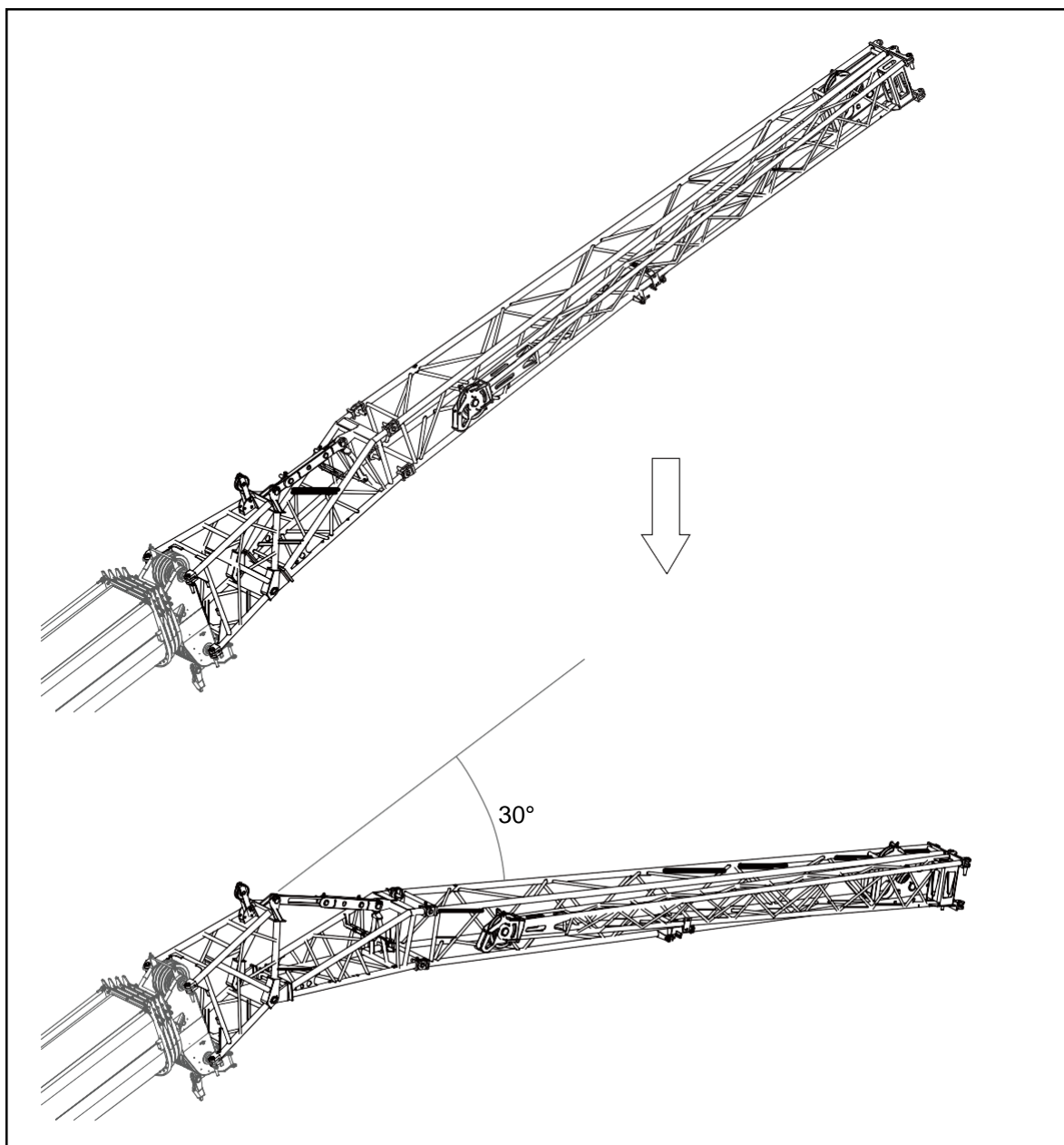

Não acelere excessivamente o guincho auxiliar ao desmontar o braço.

Após a montagem e desmontagem do braço, ajuste o parafuso de limite no lado esquerdo da cabeça de lança principal (visualizado da direção de percurso), até a folga entre a superfície da extremidade do parafuso de limite e o bloco de mancal na cabeça da lança ser igual ou superior a 5 mm, para impedir danos ao parafuso de limite durante telescopagem de lança.

5.2.5 Passagem no cabo de elevação auxiliar

- Passa o cabo de arame do guincho auxiliar através da extremidade do guia do cabo na lança básica.
- Passa o cabo de arame através das polias de guia de cabo para a polia de cabeça de seção de braço I ou polia de cabeça de seção de braço II e depois passe sob os tubos de fixação de cabo I e II, ou tubos de fixação de cabo III e IV.
- Remova o tubo de fixação de cabo II e seu grampo de retenção.
- Instale o conjunto de calço e soquete .
- Instale o gancho auxiliar.
- Instale o tubo de fixação de cabo II e seu grampo de retenção. Consulte a



figura 5-15.

Figura 5-15 Tubos de fixação de cabo

5.2.6 Conexão do interruptor de fim de curso de elevação

Para conexão do interruptor de fim de curso de elevação, consulte a figura 5-16.

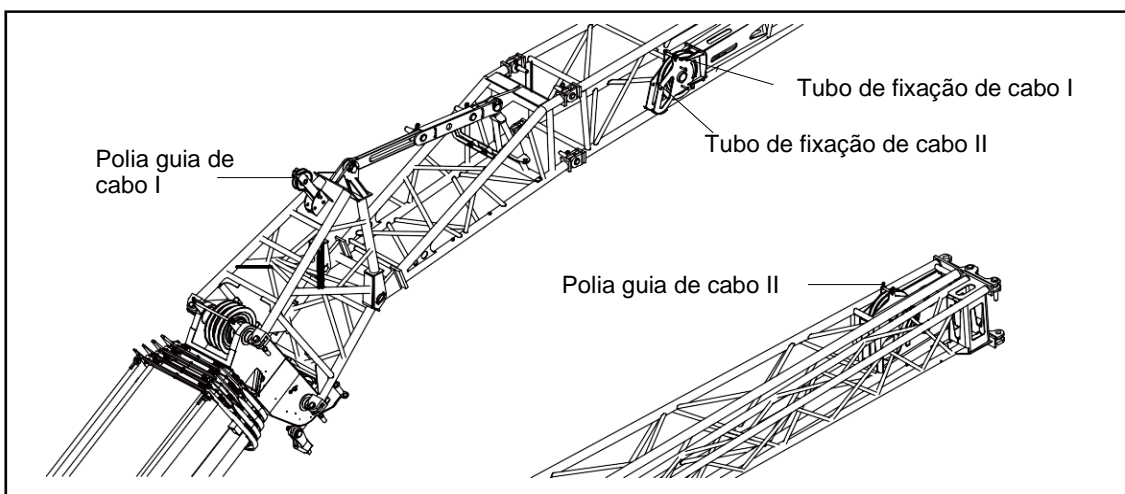
Para um modo operacional com a seção de braço 1 instalada (consulte a figura 5-16):

- Remova o plugue do cabo na traseira do adaptador do braço.
- Conecte no soquete na cabeça de lança principal.
- Remova o plugue do cabo na traseira da seção do braço 1.

- d) Conecte no soquete na cabeça do adaptador de braço.



Figura 5-16 Conexão do chicote de fios da seção de braço 1

Para um modo operacional com a seção de braço 2 instalada (consulte a figura 5-17):

- Conecte adequadamente o chicote de fios da seção de braço I, de acordo com os métodos mencionados acima.
- Remova o plugue do cabo na traseira da seção do braço 2.
- Conecte no soquete na cabeça da seção de braço 1.

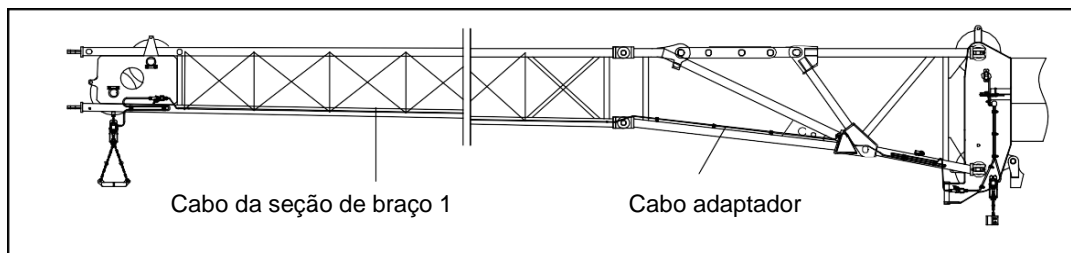

Figura 5-17 Conexão de cabo com seção de braço 1 e seção de braço 2

AVISO

Antes de montar, retraia ou desmonte o braço, desconecte todos os cabos.

Caso contrário, o cabo pode quebrar!

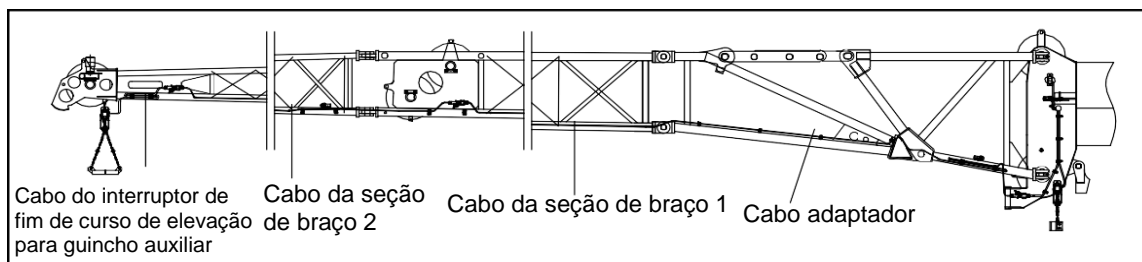
Quando o braço e adaptador estiverem instalados:

- Remova o plugue do cabo na extremidade do suporte de conexão do braço e conecte no soquete na cabeça da lança principal;
- Remova o plugue na extremidade do adaptador e conecte no soquete na cabeça do suporte de conexão de braço.
- Conecte o cabo de acordo com as instruções apresentadas acima. Consulte a figura 5-18.



Figura 5-18 Conexão de cabo do adaptador e braço

5.3 Lança de extremidade

5.3.1 Geral

A lança de extremidade é um dos componentes mais importantes dos caminhões guindastes. Com a lança de extremidade montada, a carga pode ser levantada até uma altura mais alta e o raio de trabalho pode ser aumentado. A lança de extremidade de seção simples (opcionais) se conecta à lança por pinos. A montagem da lança de extremidade é a mesma que o braço. Consulte a figura 5-19.

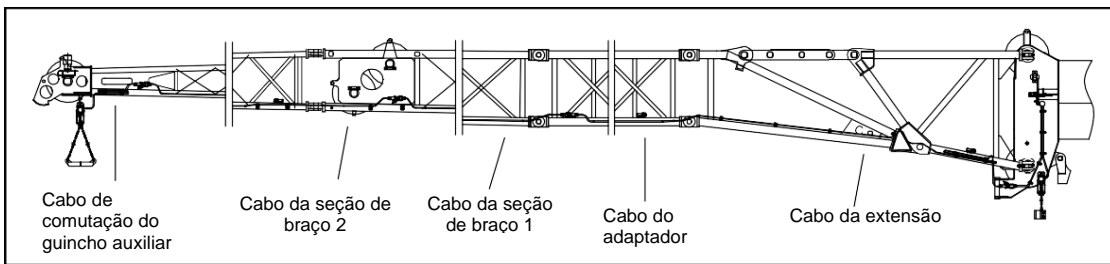

Figura 5-19 Lança de extremidade



(1) Não é possível utilizar a lança de extremidade ao levantar uma carga se

o guindaste não for suportado em estabilizadores.

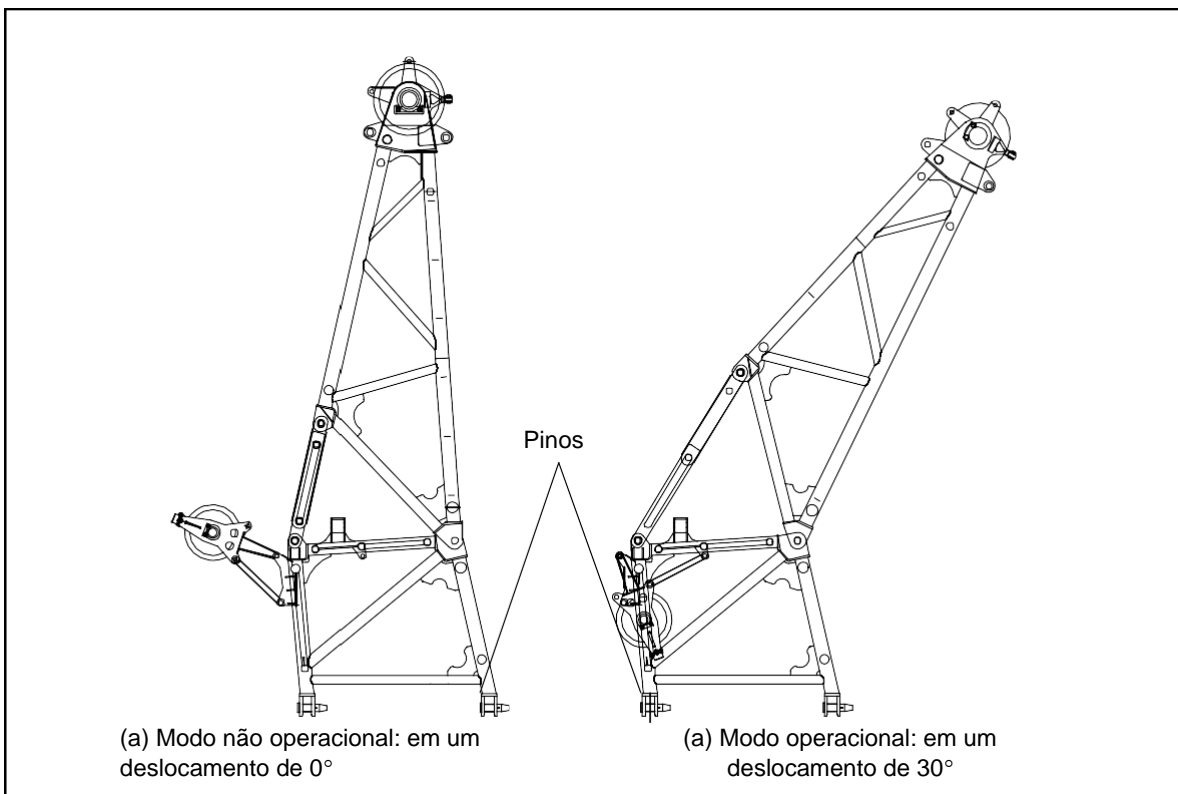
- (2) **Ajuste o deslocamento da lança de extremidade para 30° antes de iniciar uma operação de levantamento. Ajuste o deslocamento para 0° quando a operação não utilizar a lança de extremidade.**

5.3.2 Montagem

A lança de extremidade tem dois deslocamentos de 0° e 30°. Antes de começar uma operação de levantamento, monte a lança de extremidade em um deslocamento de 30°.

Monte a lança de extremidade (considere deslocamento 0°, por exemplo).

- Estenda os estabilizadores e nivele o guindaste.
- Retraia a lança totalmente.
- Mova a lança para o lado ou traseira do guindaste e posicione até o ângulo mínimo.
- Verifique se há faixa de giro de 20 m até o centro do giro.
- Alinhe a extremidade do adaptador com os pontos de conexão na extremidade do quadro do triângulo. Instale os pinos e grampos de retenção. Consulte a figura 5-20.



Figura 5-20 Montagem da lança de extremidade

- Levante a lança de extremidade montada com um guindaste auxiliar até os pontos de conexão no adaptador estarem alinhados com os pontos de conexão na cabeça da lança principal. Instale os pinos e grampos de retenção.

- g) Instale as placas de contrapeso e o interruptor de fim de curso de elevação.
Verifique se a montagem está adequada.

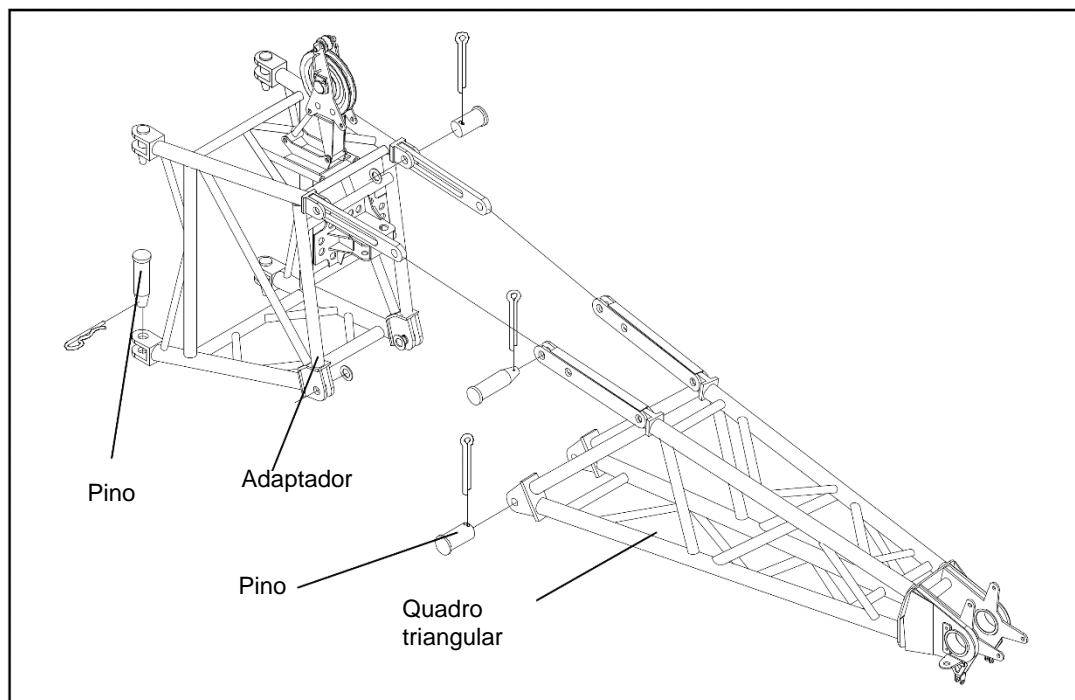

Perigo de ferimentos fatais devido à queda de componentes!

Não se posicione sob a lança ou lança de extremidade durante a montagem.

A lança de extremidade ou outros componentes podem cair devido a erro de montagem.

5.3.3 Ajustes de ângulo

A lança de extremidade pode ser operada em ângulos de 0° e 30°. O ângulo relevante é definido utilizando pinos. Consulte a figura 5-21.



Figura 5-21 Posições de deslocamento

Modifique o deslocamento da lança de extremidade de 0° para 30° (consulte a figura 5-14):

- a) Bobine o cabo de elevação auxiliar para 2 m a 3 m ao mover o joystick.
- b) Abaixar a lança até o ângulo mínimo, até a lança de extremidade entrar em contato com o solo ou estar suportada adequadamente.
- c) Remova o pino e grampo de retenção no ponto B.
- d) Levante a lança lentamente até o suporte de empuxo tocar no pino apropriado e o deslocamento mudar para 30°.

5.3.4 Desmontagem

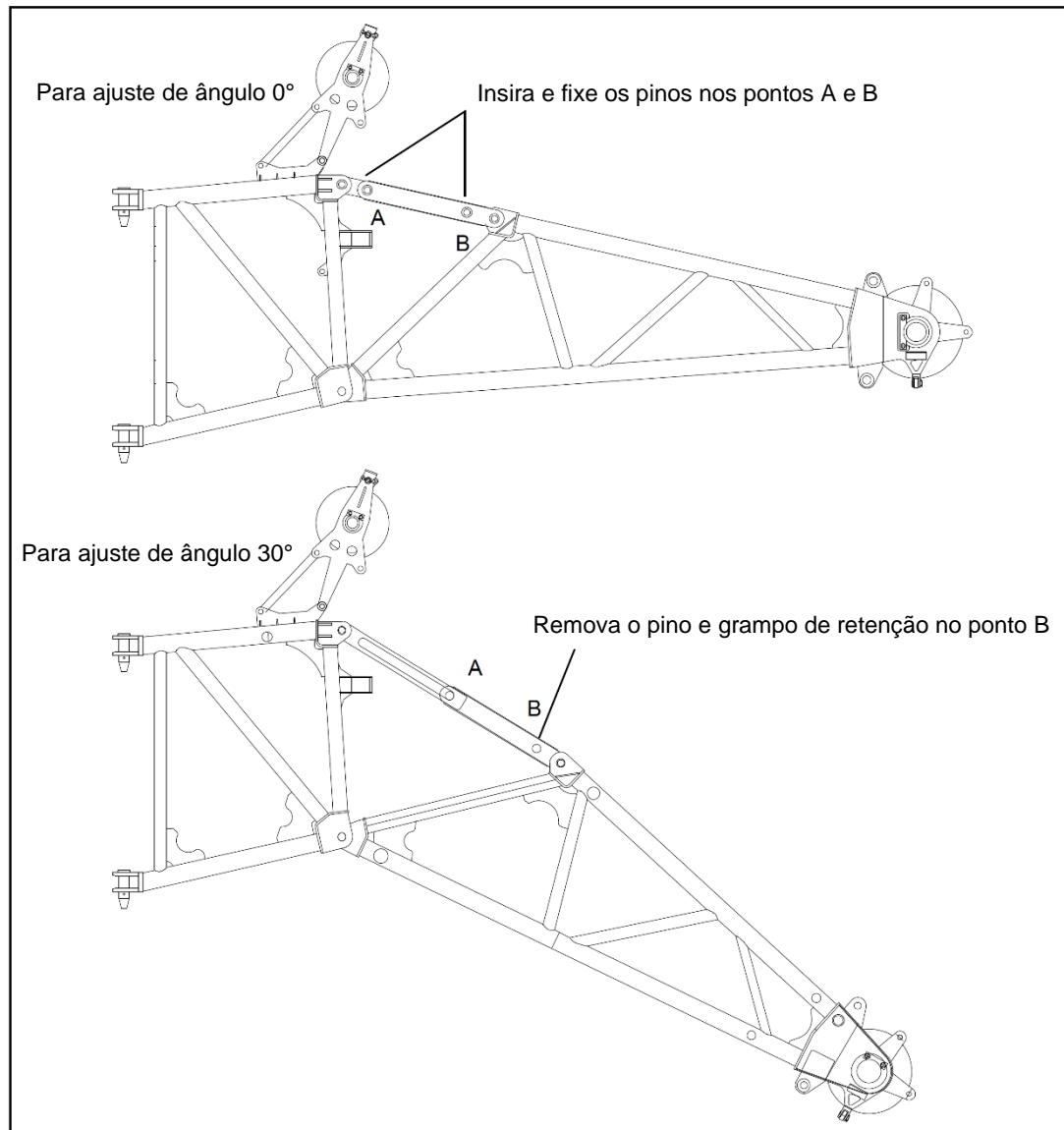
5.3.4.1 Remoção

Após completar a operação da lança de extremidade, desmonte-a em ordem inversa aos passos de montagem.



CUIDADO

Não conecte a lança de extremidade no lado da lança principal durante a condução do veículo. Caso contrário, os eixos serão seriamente danificados devido à sobrecarga.

5.3.5 Passagem no cabo de elevação

- a) Passe o cabo de elevação do guincho principal ou auxiliar e puxe no suporte de polia de guia de cabo no adaptador.
- b) Remova os tubos de fixação de cabo.
- c) Passe o cabo de elevação através do suporte de polia de guia de cabo.
- d) Instale os tubos de fixação de cabo.
- e) Guie o cabo de elevação na polia na parte superior da lança de extremidade.
- f) Remova os tubos de fixação de cabo.
- g) Passe o cabo de elevação através da polia na cabeça da lança de extremidade e polia de gancho.
- h) Instale os tubos de fixação de cabo.
- i) Conecte o conjunto de calço e soquete na placa de montagem na parte inferior da cabeça de lança de extremidade.

Consulte a figura 5-22.



Figura 5-22 Passagem no cabo de elevação para lança de extremidade

! CUIDADO

É recomendado utilizar o cabo de elevação no guincho principal para lança de extremidade. Ao utilizar o cabo de guincho auxiliar no guincho auxiliar, verifique se o cabo é longo o suficiente.

5.3.6 Conexão elétrica

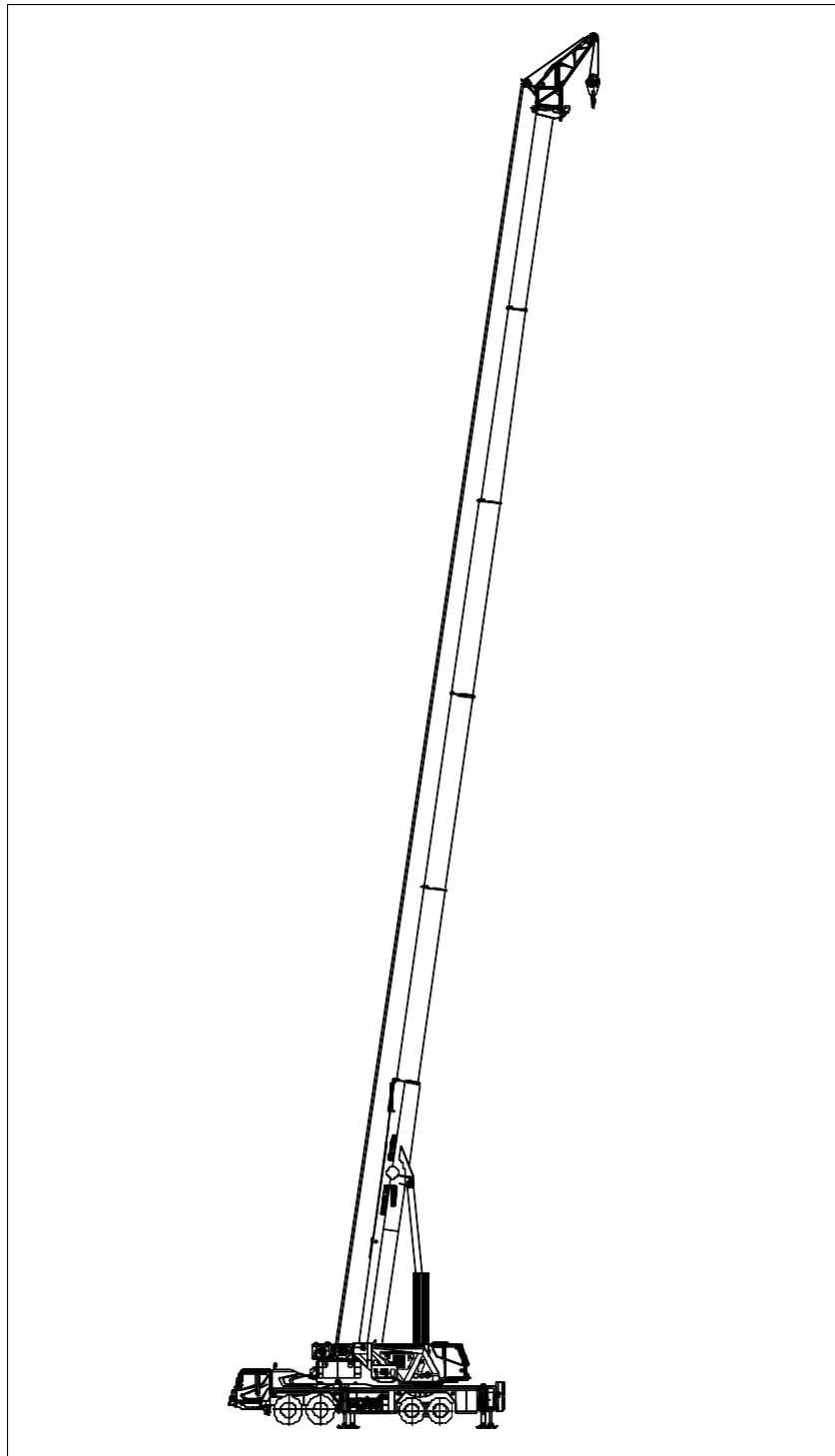
Para conexão elétrica de lança de extremidade, consulte a figura 5-23.



Figura 5-23 Conexão elétrica da lança de extremidade

CUIDADO

- (1) Proteja os plugues e soquetes utilizados para conexão elétrica com carcaça protetora preta contra contaminação e poeira.
- (2) Antes de desmontar a lança de extremidade, desconecte o chicote de fios do interruptor de fim de curso de elevação para lança de extremidade e chicote de fios da lança de extremidade. Caso contrário, o chicote de fios pode quebrar!
- (3) O elemento elétrico principal é o interruptor de fim de curso de elevação para o guincho.

Como conectar:

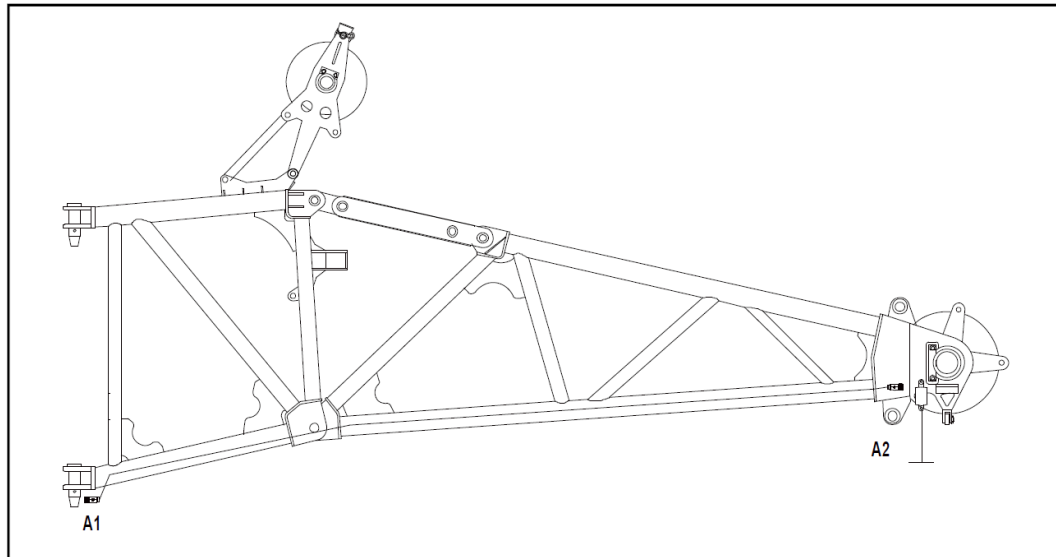
- a) Conecte o terminal A1 do chicote de fios no adaptador I do elemento de conexão de chicote de fios no interruptor de fim de curso de elevação (para guincho principal/auxiliar) na cabeça de lança principal.
- b) Conecte o terminal A2 do chicote de fios no adaptador do elemento de conexão no interruptor de fim de curso de elevação.

5.4 Roldana de cabeça

Os componentes da roldana de cabeça são como segue:

- Suporte
- Fuso de roldana
- Roldana
- Pinos

Quando não for necessário utilizar a roldana de cabeça, verifique se está conectada ao lado da seção de lança superior.

Quando o guindaste for levantar uma carga leve, use a roldana de cabeça. Esse é o modo mais eficiente de mover um objeto mais leve.

5.4.1 Montagem

- Retraia totalmente a lança.
- Mova a lança pelos lados e traseira e ajuste a lança na posição -2° .
- Remova o pino de fixação e mova o suporte até a frente da lança. Alinhe os pontos de conexão. Instale o pino de conexão. Consulte a figura 5-24.
- Passo o cabo de elevação auxiliar através da polia de cabo superior e roldana de cabeça. Instale o gancho auxiliar e o interruptor de fim de curso de elevação. Verifique se todas as conexões estão apertadas.



Figura 5-24 Montagem de roldana de cabeça

5.4.2 Desmontagem

Quando não for necessário utilizar a roldana de cabeça, verifique se está conectada ao lado da lança. Desmonte na ordem inversa do procedimento de montagem.

5.4.3 Conexão do interruptor de fim de curso de elevação

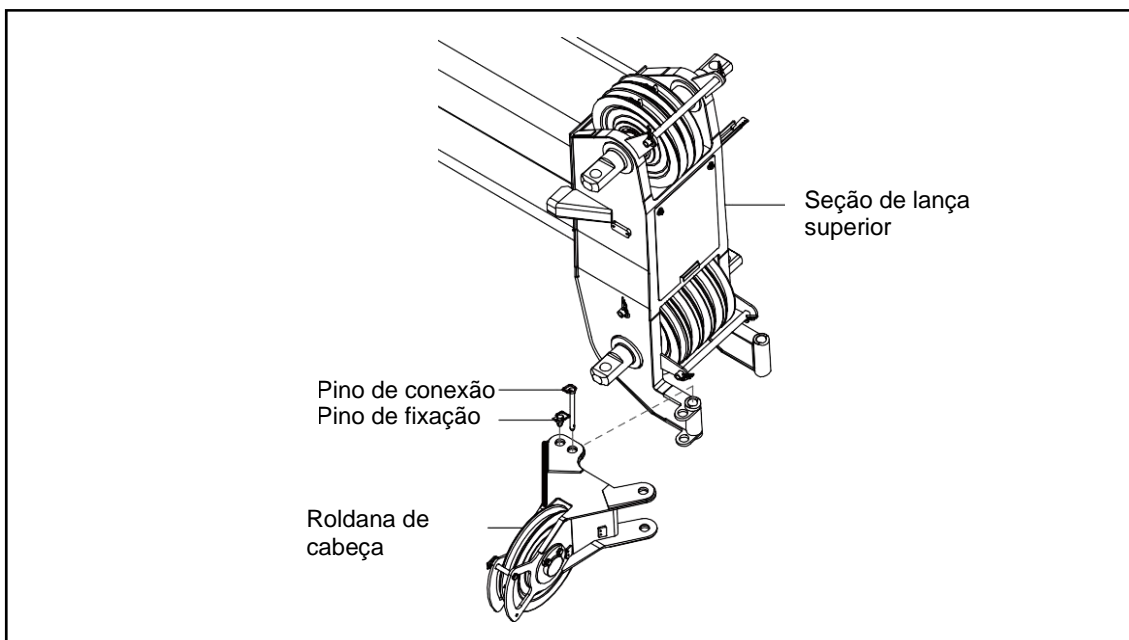
De acordo com a condição de operação da roldana de cabeça:

- Remova o interruptor de fim de curso de elevação no braço.
- Instale no lugar mostrado na figura a seguir.
- Conecte o plugue de cabo na cabeça da lança principal. Consulte a figura 5-25.



Figura 5-25 Conexão de cabo com roldana de cabeça

AVISO

Antes de montar ou desmontar a roldana de cabeça, desconecte todos os cabos. Caso contrário, o cabo pode quebrar!

5.5 Extensão

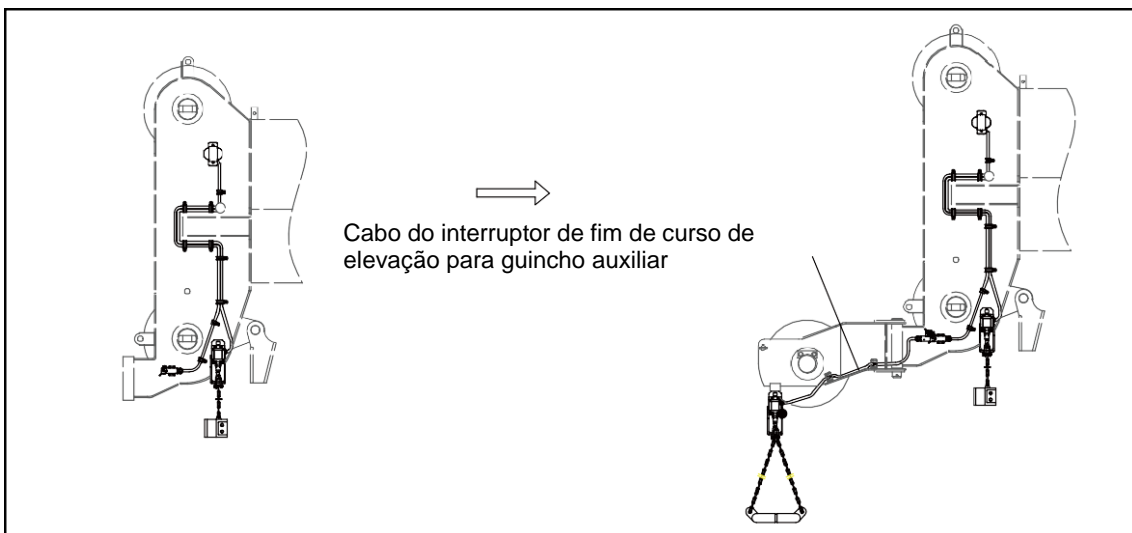
5.5.1 Visão geral

Uma extensão é uma estrutura mecânica importante do guindaste e pode ser utilizada para levantar uma carga até uma posição mais alta e em um raio de trabalho mais amplo, em comparação quando apenas a lança principal é utilizada. Pode ser utilizada independentemente ou instalada junto com o braço. A extensão é opcional para esse guindaste. Ela é articulada e fixada por meio de pinos à lança principal e braço, como mostrado na figura 5-26.



Figura 5-26 Extensão



1. Preste atenção ao comprimento de lança principal e combinação de seção de lança nas tabelas de capacidade de levantamento quando a extensão for utilizada.
2. Quando a extensão for utilizada independentemente, remova o braço instalando no lado direito da lança principal.
3. Um gancho opcional de 18 t deve ser utilizado quando a extensão for usada independentemente.
4. Certifique-se de estender os estabilizadores na posição antes de levantar uma carga com a extensão.

5.5.2 Montagem

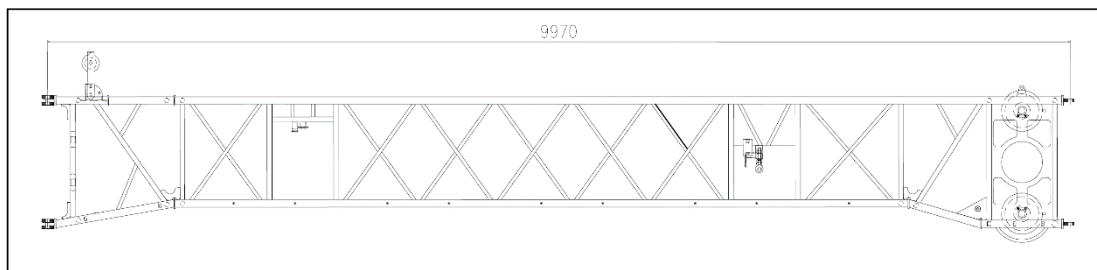
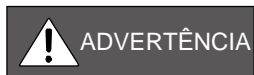
A extensão pode ser utilizada apenas em um deslocamento de 0° na lança principal, para ambas as operações de levantamento de carga e durante o transporte.

O modo de instalação depende de seu modo de transporte. Quando for transportado com o guindaste, pode ser instalado no mesmo procedimento que do braço; quando for transportado por um caminhão, deve ser instalado ao utilizar um dispositivo de elevação auxiliar.

Para o caso anterior, a instalação da extensão inclui um passo extra de desdobramento de seu suporte de instalação traseira, como abaixo, enquanto o restante dos passos de instalação é o mesmo que o do braço; a) Remova os dois pinos de conexão e tire o suporte removível do membro da correia da extensão, como mostrado na figura 5-18.

AVISO

Impeça que o suporte removível caia ao remover os pinos.



Figura 5-27 Remoção do suporte móvel

b) Instale o suporte removível no suporte de fixação, como mostrado na figura 5-28.

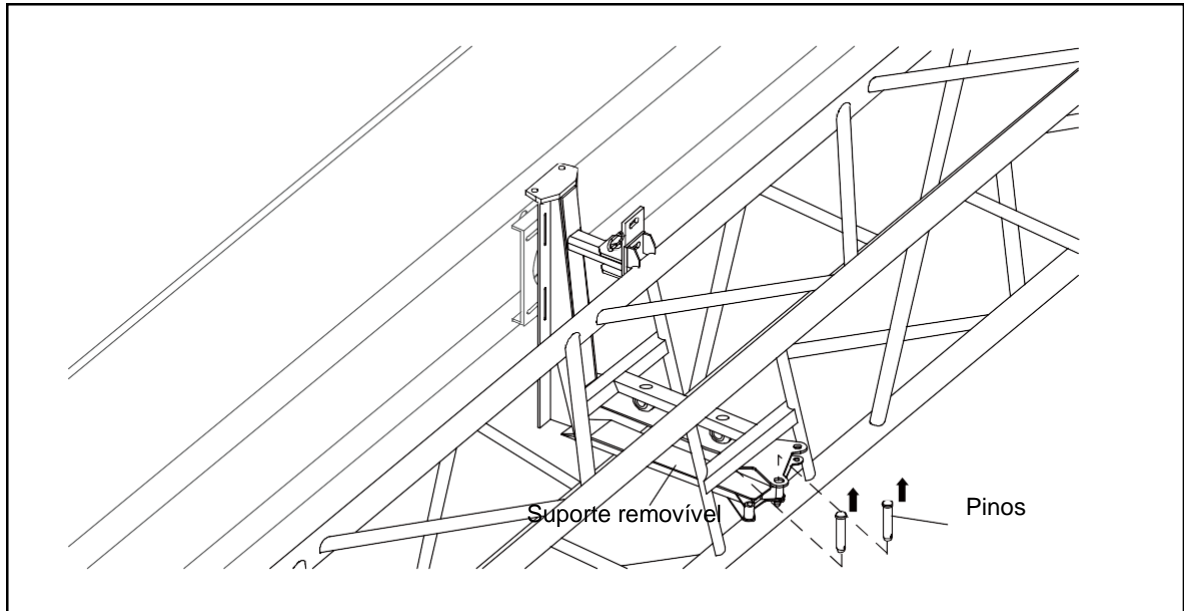

Figura 5-28 Instalação do suporte removível

5.5.3 Desmontagem

5.5.3.1 Remoção para transporte em caminhão

Após a operação de levantamento ser completada utilizando a extensão, remova

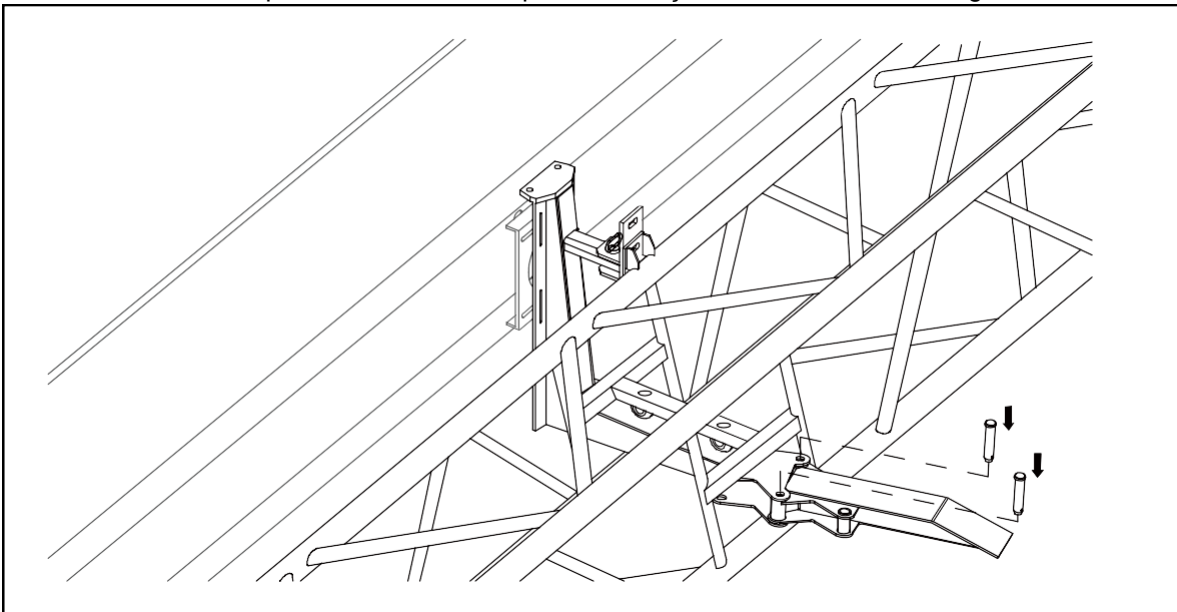
a extensão utilizando um dispositivo de elevação e coloque em um caminhão para transporte.

5.5.3.2 Remoção para instalação na lança principal

Após a operação de levantamento ser completada utilizando a extensão, remova a extensão utilizando um dispositivo de elevação instalado do lado direito da lança principal. Essa instalação pode ser feita em uma ordem inversa à instalação do braço. A retração do suporte móvel da extremidade traseira pode ser feita em ordem inversa a seu desdobramento.



A extensão ou o braço pode ser selecionado para transporte com o guindaste.

5.5.4 Passagem na extensão

Passagem de cabo de arame que é utilizada independentemente, como mostrado na figura 5-29. O cabo de arame é extraído da direção longitudinal, ao longo da lança principal, diretamente do guincho principal ou auxiliar e é enrolado através do suporte de cabo de arame, polia na cabeça da lança principal e polia I e II na cabeça da extensão, respectivamente. Ele é conectado ao gancho auxiliar finalmente.



Figura 5-29 Passagem do cabo de arame auxiliar

5.5.5 Passagem na extensão e braço

Passagem na extensão e braço, como mostrada na figura 5-30.

O cabo de arame é extraído da direção longitudinal ao longo da lança principal, diretamente do guincho principal ou auxiliar e é enrolado através do suporte de cabo de arame, polia na extremidade do braço e polia na cabeça do braço, respectivamente (nota: para um braço de duas seções, o cabo de arame deve ser enrolado através de outra polia, na cabeça do braço de seção tipo caixa). Ele é conectado ao gancho auxiliar finalmente.

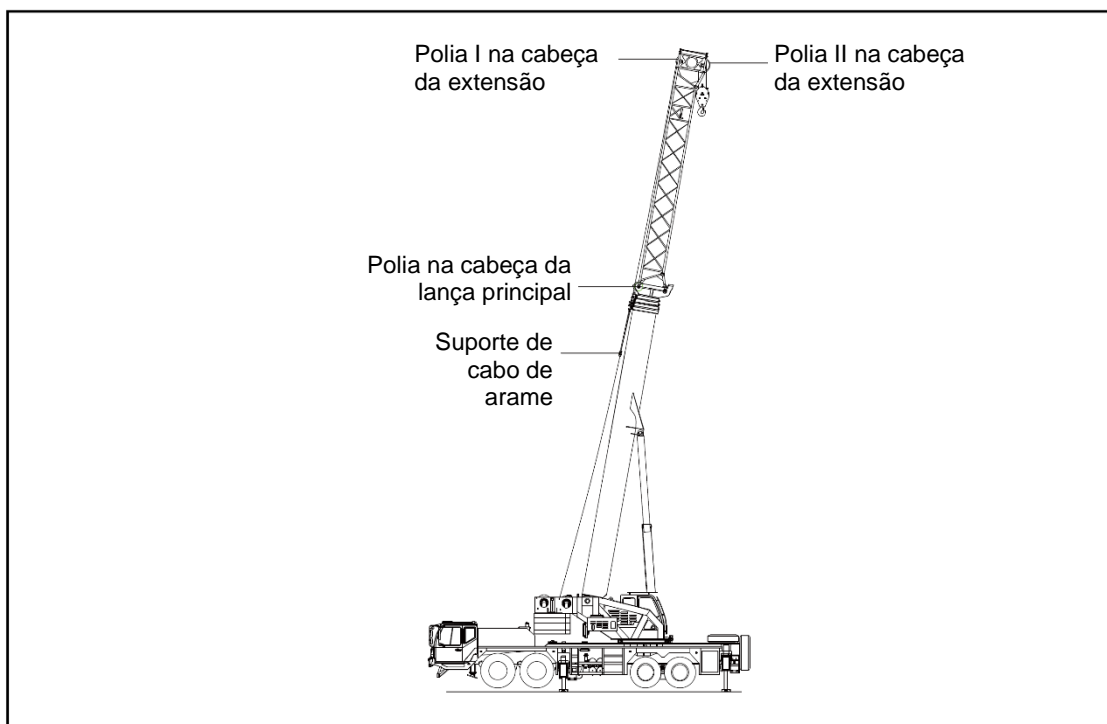

Figura 5-30 Passagem do cabo de arame auxiliar



Quando a extensão for utilizada, é recomendado utilizar o guincho auxiliar para garantir que o comprimento do cabo de arame seja suficiente. Avalie se o cabo de arame é longo o suficiente antes de utilizar o guincho principal.

5.5.6 Conexão do interruptor de fim de curso de elevação

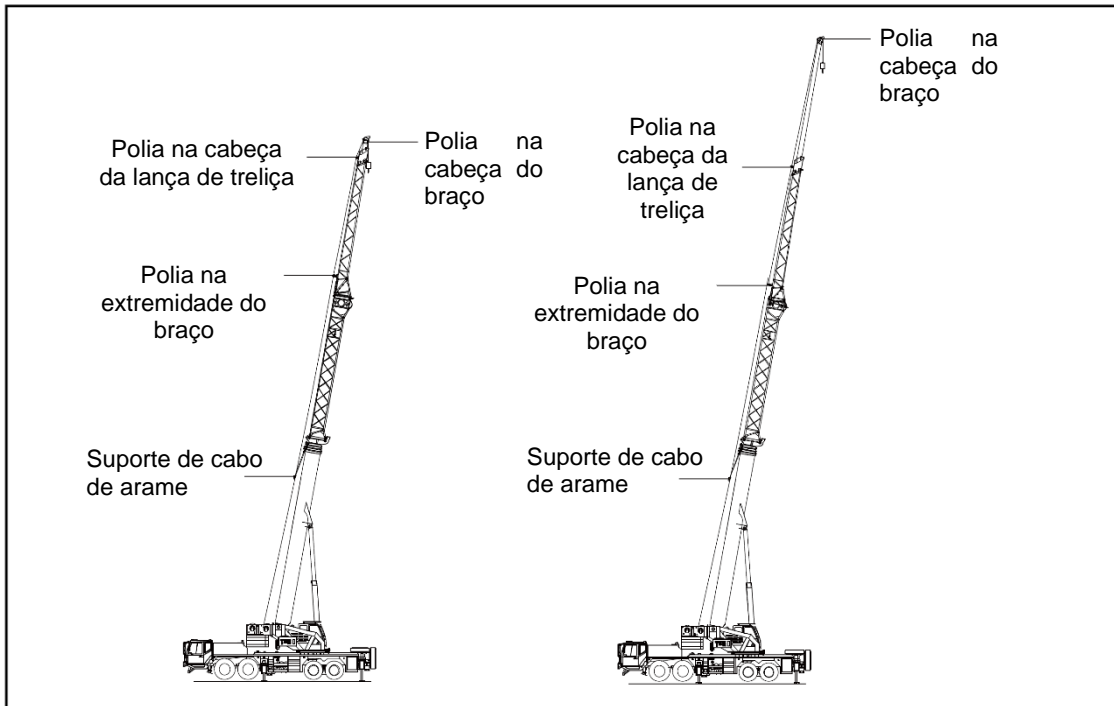
Quando a extensão for utilizada independentemente, conecte o interruptor de fim de curso de elevação de acordo com os passos a seguir:

- Remova o interruptor de fim de curso de elevação instalado no braço e instale na posição, como mostrado na figura 5-31;
- Conecte o plugue de cabo do interruptor de fim de curso de elevação no soquete na extremidade dianteira da extensão;
- Remova o plugue do cabo na extremidade da extensão e conecte no soquete na cabeça da lança principal.



Figura 5-31 Conexão de cabo na extensão

Quando a extensão for utilizada juntamente com o braço, conecte o interruptor de fim de curso de elevação de acordo com os passos a seguir:

- Remova o plugue do cabo na extremidade da seção de treliça do braço e conecte no soquete na extremidade dianteira da extensão;
- Remova o plugue do cabo na extremidade da extensão e conecte no soquete na cabeça da lança principal;
- Conecte o cabo do braço de acordo com suas condições de uso.

Consulte a figura 5-32.

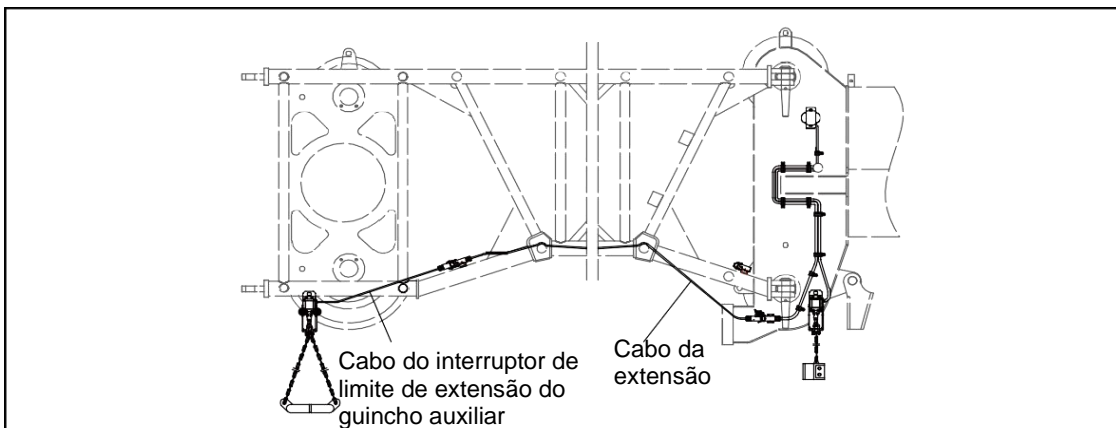

Figura 5-32 Conexão do cabo de extensão

5.6 Contrapeso

5.6.1 Contrapeso e manipulador de contrapeso

Composição da montagem do contrapeso, como mostrada na figura 5-33:

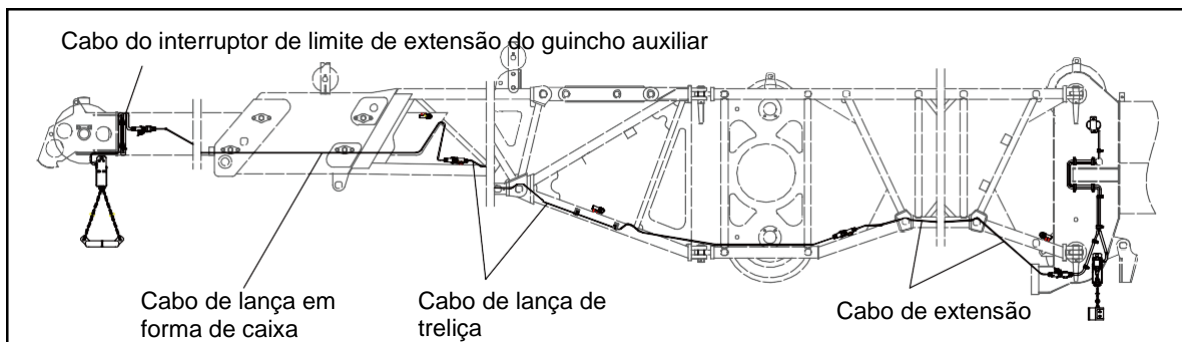
- Uma placa de contrapeso fixa (3 t)
- Uma placa de contrapeso auxiliar (8 t)
- Uma placa de contrapeso móvel superior (4 t)
- Uma placa de contrapeso móvel intermediária (4 t)
- Uma placa de contrapeso móvel inferior (4 t)
- Duas placas de contrapeso

laterais (5,5 t *2) Peso total: 34 toneladas

Há 5 variantes de contrapeso disponíveis.

- **Variante 1:** 3 t no total, consistindo de placa de contrapeso fixa (3 toneladas).
- **Variante 2:** 11 t no total, consistindo de placa de contrapeso fixa (3 toneladas) + placa de contrapeso auxiliar (8 toneladas).
- **Variante 3:** 15 t no total, consistindo de placa de contrapeso fixa (3 toneladas) + placa de contrapeso auxiliar (8 toneladas) + placa de contrapeso móvel (4 toneladas)
- **Variante 4:** 19 t no total, consistindo de placa de contrapeso fixa (3 toneladas) + placa de contrapeso auxiliar (8 toneladas) + placa de contrapeso móvel inferior (4 toneladas) + placa intermediária móvel (4 toneladas).
- **Variante 5:** 23 t no total, consistindo de placa de contrapeso fixa (3 toneladas) + placa de contrapeso auxiliar (8 toneladas) + placa de contrapeso móvel inferior (4 toneladas) + placas intermediárias móveis (4 toneladas) + contrapeso móvel superior (4 toneladas).
- **Variante 6:** 34 t no total, consistindo de placa de contrapeso fixa (3 toneladas) + placa de contrapeso auxiliar (8 toneladas) + placa de contrapeso móvel inferior (4 toneladas) + placas intermediárias móveis (4 toneladas) + contrapeso móvel superior (4 toneladas) + duas placas de contrapeso laterais (5,5*2 toneladas).



Figura 5-33 Conjunto de contrapeso

Os componentes do manipulador de contrapeso são como segue:

- Cilindros de levantamento de contrapeso (esquerdo e direito)
- Duas travas hidráulicas e outros elementos auxiliares. Consulte a figura 5-34.

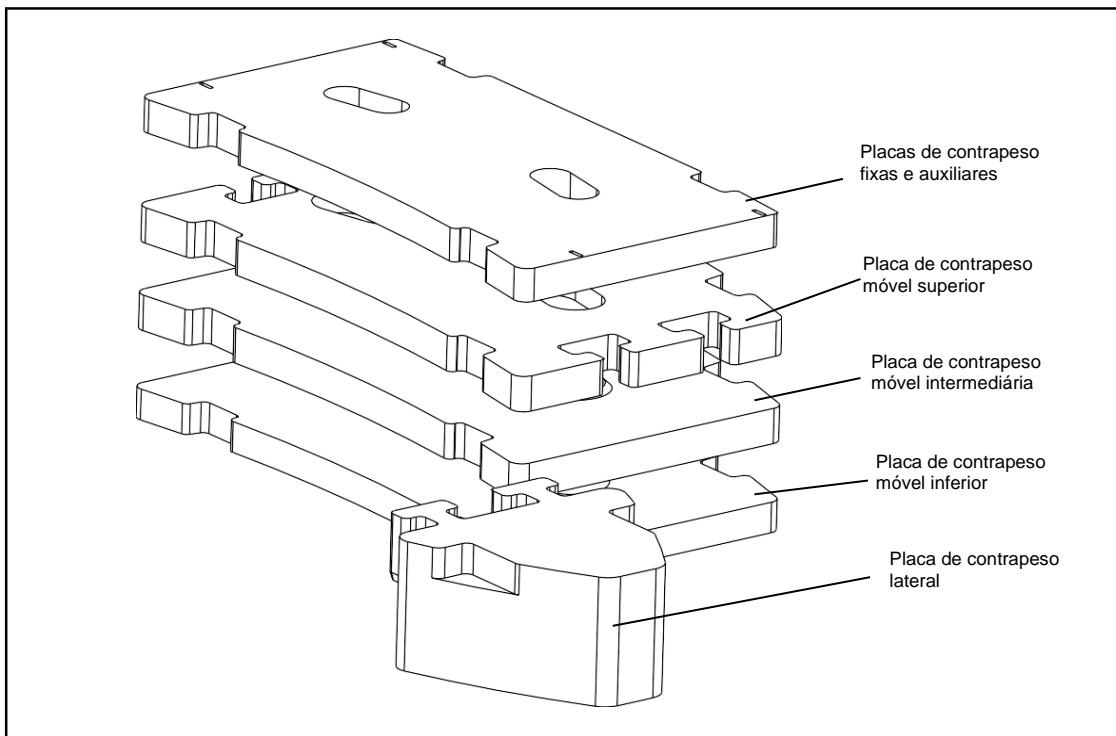

Figura 5-34 Manipulador de contrapeso



Risco de acidente ao tombar o guindaste!

Conecte o contrapeso de acordo com as informações nas tabelas de capacidade de levantamento.

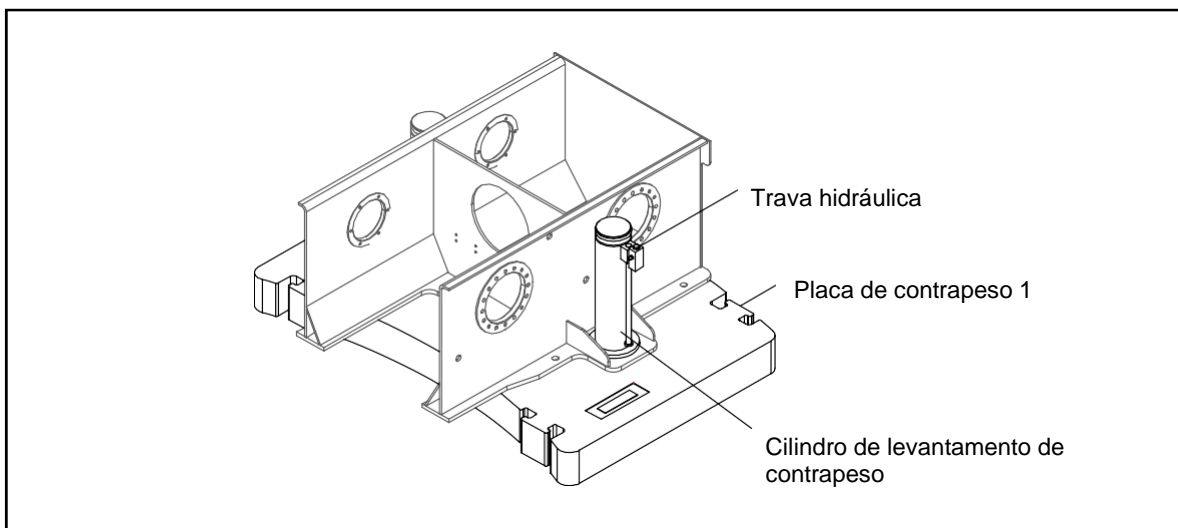
Se um contrapeso diferente da lista na tabela de capacidade de levantamento for utilizado, o guindaste tomba.

5.6.2 Caixa de controle remoto de contrapeso

5.6.2 Caixa de controle remoto de contrapeso

Ative o controle remoto de contrapeso nos passos a seguir:

- Pressione o interruptor pré-seleção de levantamento de contrapeso.
- Conecte no plugue da caixa de controle remoto no soquete na seção intermediária da tabela de giro.

O painel do transmissor remoto é como mostrado na figura 5-35.



Figura 5-35 Painel de controle remoto da caixa de controle remoto

Tabela 5-1 Descrição dos botões no transmissor remoto

Pos.	Descrição	Pos.	Descrição
1	Botão de Parada	6	Botão Abaixamento simultâneo
2	Botão de Parada	7	Botão Levantamento de cilindro de contrapeso esquerdo
3	Botão Giro à esquerda	8	Botão Levantamento de cilindro de contrapeso direito
4	Botão Giro à direita	9	Botão Abaixamento de cilindro de contrapeso esquerdo
5	Botão Levantamento simultâneo	10	Botão Abaixamento de cilindro de contrapeso direito

Tabela 5-2 Função dos botões no transmissor remoto

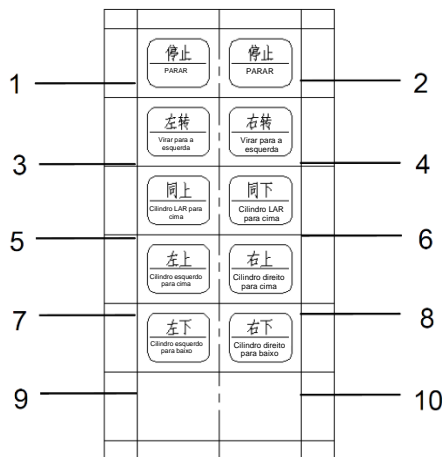
Pos.	Descrição	Descrição de função	Observação
1	Botão de Parada	Todos os movimentos param quando o botão é pressionado	
2	Botão de Parada	Todos os movimentos param quando o botão é pressionado	
3	Botão Giro à esquerda	A mesa de giro gira para a esquerda	O giro à esquerda e direita é intertravado, portanto o aperto simultâneo dos dois botões é inválido
4	Botão Giro à direita	A mesa de giro gira para a direita	
5	Botão de levantamento simultâneo	Os cilindros de contrapeso esquerdo e direito são levantados simultaneamente após esse botão ser pressionado.	As operações a seguir são intertravadas uma com a outra. Quando dois botões de controle de duas operações intertravadas forem pressionados simultaneamente, a saída de controle é inválida. - Levantamento e abaixamento do contrapeso esquerdo - Levantamento e abaixamento do contrapeso direito - Levantamento simultâneo e abaixamento de contrapeso esquerdo/direito - Abaixamento simultâneo e levantamento de contrapeso esquerdo/direito
6	Botão de abaixamento simultâneo	Os cilindros de contrapeso esquerdo e direito são abaixados simultaneamente após esse botão ser pressionado.	
7	Botão Levantamento de cilindro de contrapeso esquerdo	O cilindro de contrapeso esquerdo é levantado após esse botão ser pressionado.	
8	Botão Levantamento de cilindro de contrapeso direito	O cilindro de contrapeso direito é levantado após esse botão ser pressionado.	
9	Botão Abaixamento de cilindro de contrapeso esquerdo	O cilindro de contrapeso esquerdo é abaixado após esse botão ser pressionado.	
10	Botão de abaixamento de cilindro de contrapeso direito	O cilindro de contrapeso direito é abaixado após esse botão ser pressionado.	

Antes de operar o controle remoto, coloque a tira de teclas na ranhura de teclas. A luz indicadora pisca uma vez. Após o controle remoto enviar sinais de controle, a luz indicadora pisca continuamente.

5.6.2 Montagem

Monte o sistema de contrapeso nos passos a seguir:

- Estenda todos os estabilizadores para suportar o guindaste e ajuste seu nivelamento.
- Retraia totalmente o cilindro de levantamento de contrapeso.
- Verifique se não há pessoal localizado na faixa de giro do guindaste nem nenhum

dispositivo que possa ser danificado durante o processo.

- d) Prepare eslingas de resistência suficiente.
- e) Levante a placa de contrapeso móvel inferior no bloco de fixação ao operar o guindaste; levante outras placa de contrapeso conforme necessário.
- f) Após colocar as placas de contrapeso, pressione o interruptor de pré-seleção de levantamento de contrapeso e ar condicionado.
- g) Conecte no plugue da caixa de controle remoto de contrapeso no soquete na seção intermediária da tabela de giro. Dessa forma, a caixa de controle remoto fica operacional.
- h) Conecte a caixa de controle remoto e depois gire a mesa de giro no sentido horário, até o cilindro de levantamento de contrapeso repousar na posição lateral da ranhura de montagem do tambor de levantamento.
- i) Estenda o cilindro de levantamento de contrapeso totalmente.
- j) Continue a girar a mesa de giro no sentido horário, até o cilindro repousar na fenda de instalação do cilindro de levantamento da placa de contrapeso móvel inferior.
- k) Retraia o cilindro de levantamento de contrapeso totalmente, até um som de transbordamento da válvula de transbordamento ser ouvido. Dessa forma, o contrapeso é levantado até sua posição.

**CUIDADO**

- a) **Ao conduzir com diferentes combinações de contrapeso, a velocidade de condução mais alta do guindaste é diferente, como segue:**
 - **Status de condução 1:** quando o guindaste for instalado com contrapeso 3 t, isto é, a placa de contrapeso fixa 3 t, o guindaste pode ser conduzido a uma velocidade mais alta, conforme especificado na ficha de dados.
 - **Status de condução 2:** quando o guindaste for instalado com contrapeso 11 t, isto é, a placa de contrapeso fixa 3 t + placa de contrapeso auxiliar 8 t, o guindaste pode ser conduzido a uma velocidade mais alta, conforme especificado na ficha de dados.
 - **Status de condução 3:** quando o guindaste for instalado com contrapeso 15 t, isto é, a placa de contrapeso fixa 3 t + placa de contrapeso auxiliar 8 t + placa de contrapeso móvel inferior 4 t (no assento de montagem de contrapeso), o guindaste pode ser conduzido a uma velocidade mais alta, conforme especificado na ficha de dados.
 - **Status de condução 4:** quando o guindaste for instalado com contrapeso 9 t, isto é, a placa de contrapeso fixada 3 t + placa de contrapeso auxiliar 8 t (na extremidade da mesa de giro) + placa de contrapeso móvel inferior 4 t + placa de contrapeso móvel intermediária (na frente da cabine do operador), a velocidade máxima de condução é

limitada a 50 km/h.

- **Status de condução 5:** quando o guindaste for instalado com contrapeso 23 t, isto é, a placa de contrapeso fixa 3 t + placa de contrapeso auxiliar 8 t (na extremidade da mesa de giro) + placa de contrapeso móvel inferior 4 t + placa de contrapeso móvel intermediária + placa de contrapeso móvel superior 4 t (na frente da cabine do operador), a velocidade máxima de condução é limitada a 50 km/h.

- b) É estritamente proibido conduzir o guindaste em rodovias quando for de status de condução 4 e 5, uma vez que isso pode encurtar o levantamento de serviço de eixos de condução, pneus e suspensões.

Consulte a tabela 5-3 para a velocidade mais alta de percurso e capacidade de rampa máxima correspondentes a diferentes combinações de contrapeso e status de condução:

Tabela 5-3 Velocidade mais alta de percurso e capacidade de rampa máxima correspondentes a diferentes combinações de contrapeso

Status de condução	Combinações de contrapeso	Limite de velocidade		Limite de capacidade de rampa	
		Posição de engrenagem	Velocidade alta (km/h)	Posição de engrenagem	Capacidade de rampa máxima (%)
Status 1	3T	10ª marcha	≥80	1ª marcha	40
Status 2	3T+8T		80		32
Status 3	3T+8T+4T		80		30
Status 4	3T+8T+4T+4T	9ª ou 10ª marcha	50		28
Status 5	3T+8T+4T+4T+4T		50		26

ZOOMLION

Manual do operador de caminhão guindaste

Capítulo 6 Equipamentos adicionais



Capítulo 6 Equipamentos adicionais

6.1 Ar condicionado na cabine do condutor

6.1.1 Métodos operacionais

O painel de controle está no console central na cabine do condutor.



Figura 6-1 Painel de controle, A/C e aquecedor de cabine

6.1.1.1 Identificação de símbolo

Tabela 6-1 Identificação de símbolo

Símbolo	Descrição	Símbolo	Descrição
SET	Definição		Refrigeração
AUTO	Auto		1 bar – estágio 1
	Temperatura		2 bar – estágio 2
	Circulação de ar externo		3 bar – estágio 3
	Circulação de ar interno		4 bar – estágio 4
	Alimentação de ar do piso		5 bar – estágio 5
	Ar fresco		6 bar – estágio 6:
	Alimentação de ar da janela dianteira		Carroceria de veículo

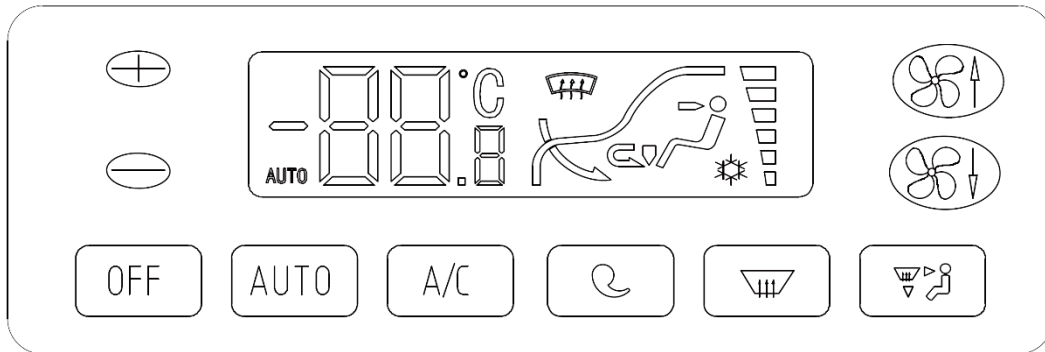
6.1.1.2 Botões

- a) **Botão de ajuste de temperatura pressionado:**

Aumentar/diminuir a temperatura.



- b) **Botão de velocidade de ventilador pressionado:**

Aumentar/diminuir a velocidade do ventilador.



- c) **Botão OFF pressionado:**

Desliga o sistema de ar condicionado.



- d) **Botão AUTO pressionado:**

Ativa o modo de operação automática.

Pressionado novamente, ou o botão A/C ou de alimentação de ar da janela dianteira é pressionado:

Sai do modo de operação automática.



- e) **Botão A/C pressionado:**

A/C começa a refrigerar.



- f) **Botão de circulação pressionado:**

Troca de circulação de ar interno/externo



- g) **Botão de alimentação de ar da janela dianteira pressionado:**

Entra no modo de alimentação de ar da janela dianteira.



- h) **Botão de modo pressionado:**

Troca entre modos diferentes de alimentação de ar.



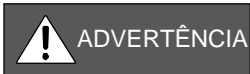

Não use o aquecedor de cabine durante a condução se a temperatura de fluido refrigerante estiver abaixo de 70°C.



- (1) Verifique se A/C está no modo OFF quando o motor estiver desligado, ou em velocidade sem carga por um longo tempo. A bateria descarrega nessas condições.
- (2) Ao mover o guindaste por uma longa distância em velocidade baixa, com A/C no modo ON coloque a transmissão em velocidade baixa. Isso aumenta o RPM do motor e diminui a carga na transmissão.
- (3) Coloque A/C na posição OFF ao executar um dos itens a seguir:
 - Mova o guindaste rapidamente.
 - Mova para cima em um aclave longo.
- (4) No inverno ou em períodos sem usar o ar condicionado, opere o ar condicionado por diversos minutos uma vez por mês, para beneficiar a circulação de lubrificação e garantir que o sistema esteja em bom estado.
- (5) Verifique se o fluido refrigerante no sistema A/C está no nível correto em intervalos regulares.
- (6) Se houver vibrações, ruídos ou cheiros incomuns durante a operação, pare e examine o guindaste imediatamente. Não opere guindaste com mau funcionamento.
- (7) Mantenha a superfície do condensador limpa. Ao limpar o condensador, não use vapor. Limpe com ar comprimido ou água fria.
- (8) Não desmonte a correia ou pipeline do compressor após não utilizá-lo por um longo tempo.
- (9) No verão, feche a válvula corretora de desligamento no tubo de água quente do aquecedor da cabine na parte inferior da cabine do condutor. Caso contrário, o efeito de refrigeração pode ser afetado. No inverno, abra a válvula corretora de desligamento para fazer com que a água quente entre no aquecedor da cabine.

6.2 Ar condicionado na cabine do operador

Para oferecer um ambiente confortável, a cabine do operador é equipada com ar condicionado e aquecedor de cabine. Ajuste a temperatura ambiente via painel de controle.

O painel de controle está atrás do painel de interruptor de controle auxiliar na cabine do operador. Há três interruptores rotativos nele. Consulte a figura 6-4.



Figura 6 -4 Painel de controle A/C

6.2.1 Ar condicionado

Execute os itens que seguem.

- Coloque o interruptor de velocidade do ventilador A/C na posição "1", "2" ou "3".
- Gire o interruptor de velocidade de ventilador A/C no sentido horário, para aumentar a capacidade de refrigeração. A/C começa a refrigerar e a temperatura ambiente na cabine começa a cair.

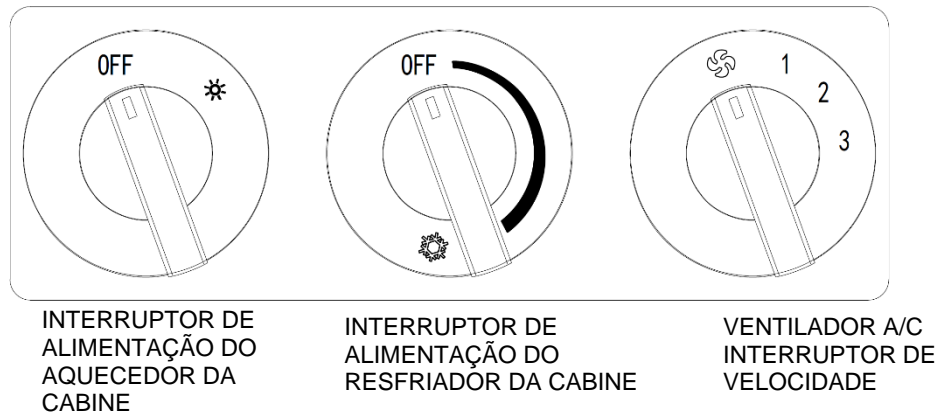
6.2.1.1 Instruções de operação

- Modo de refrigeração
 - Coloque o interruptor de velocidade do ventilador A/C na posição "3".
 - Após 5 minutos, coloque o interruptor de alimentação do resfriador de cabine no sentido horário em qualquer posição em direção à marcação de neve.

Resultado:

O modo de refrigeração está ON.

- Coloque o interruptor de alimentação do resfriador de cabine na posição OFF quando chegar na temperatura necessária.

Resultado:

O compressor para de funcionar.

Quando a temperatura na cabine for superior ao valor de ajuste:

- O compressor inicia automaticamente.
- O sistema de resfriamento começa a funcionar.

É possível ajustar o ângulo da saída de ar para mudar a direção do vento frio. E é possível utilizar o interruptor de velocidade de ventilador A/C para controlar a velocidade do ventilador do evaporador: 1, 2 e 3.

Quando o ar condicionado for utilizado, não coloque o interruptor de alimentação de resfriador de cabine na posição “NEVE”, enquanto o interruptor de velocidade de ventilador A/C estiver na posição “BAIXA”. Caso contrário, o evaporador pode ficar congelado, para prejudicar o efeito de resfriamento.



- (1) Não desmonte um sistema A/C sem autorização do fabricante de A/C.
- (2) É necessário limpar o condensador em intervalos regulares.
- (3) É necessário usar o mesmo tipo de fluido refrigerante e óleo de compressor ao trocar as peças.
- (4) É necessário usar o mesmo tipo de fluido refrigerante ao adicionar ou trocar o fluido refrigerante.
- (5) Coloque o modo de ventilador em ALTO ao ligar primeiro para resfriar a cabine. Coloque o modo de ventilador em MÉDIO ou BAIXO ao manter a temperatura de cabine apropriada.
- (6) Não use as peças para reparar o sistema A/C que não forem aprovadas pelo fabricante.
- (7) Ao usar a função A/C onde for fresco e tenha alto nível de umidade, examine o evaporador em intervalos regulares. Nessas condições, o evaporador congela e causa um bloqueio para o ar que passa através dele.
- (8) Se operar o guindaste em uma área fria ou no inverno, coloque o sistema A/C em ON por 10 minutos todo mês.

6.2.1.2 Requisitos de manutenção periódica

Tabela 6-4 Requisitos de manutenção periódica

Item	Manutenção	Intervalo de reparo
Motor de ventilador de condensador	Examine e repare.	Trimestralmente
Motor de ventilador de evaporador	Examine e repare.	Trimestralmente
Condensador	Examine e limpe.	Todo mês, ou aumente a frequência de manutenção de acordo com as condições de trabalho
Evaporador	Examine e limpe.	Todo trimestre, ou aumente a frequência de manutenção de acordo com as condições de trabalho
Conector	Verifique se o conector está instalado corretamente.	Todo mês



CUIDADO

- (1) **Evaporador - saída de ar na cabine**
- (2) **Condensador - o dispositivo é utilizado para troca de ar quente fora da cabine do condutor. Em alguns veículos, é montado entre o tanque e água e o ventilador (sem o motor do ventilador de condensador). Enquanto em outros, está do lado do veículo (com o motor de ventilador de condensador).**
- (3) **Motor de ventilador de condensador - está montado com o condensador, para ajudar na troca de ar quente.**

6.2.2 Aquecedor de cabine

Execute os itens que seguem.

- a) Coloque o interruptor de velocidade do ventilador A/C na posição “1”, “2” ou “3”.
- b) Troque a posição do interruptor de alimentação do aquecedor de cabine, de OFF para SUN. O aquecedor começa a funcionar e a temperatura ambiente na cabine começa a subir. Consulte a figura 6-4.

6.2.2.1 Condições operacionais

- a) Temperatura ambiente $\geq -40^{\circ}\text{C}$, altura acima do nível do mar ≤ 3000 m.
- b) Não pode ser imerso na água e lavado com água diretamente.
- c) O aquecedor de cabine deve utilizar anticongelante ou óleo diesel adequados para temperatura ambiente.



ADVERTÊNCIA

Não use gasolina.

6.2.2.2 Seleção de combustível e anticongelante

- a) Para seleção de combustível, consulte a tabela 6-5.

Tabela 6-5 Seleção de combustível

Temperatura ambiente	Acima de 5°C	de	Abaixo de 5°C	-	Abaixo de 15°C	-	Abaixo de 30°C	-	Abaixo de 40°C
Combustível	0# diesel	óleo	10# diesel	óleo	20# diesel	óleo	35# diesel	óleo	50# diesel

- b) Para seleção de fluido anticongelante, consulte a tabela 6-6.

Tabela 6-6 Seleção de anticongelante

Temperatura ambiente	Abaixo de -25°C	Abaixo de -40°C
Anticongelante	anticongelante -25°C	anticongelante -40°C

6.2.2.3 Instruções de operação

- a) Coloque o interruptor de alimentação do aquecedor de cabine na posição SUN.

Resultado:

A luz de controle de alimentação de ventilador no painel de interruptor de controle auxiliar está ligada. O aquecedor de cabine começa a funcionar.

- b) Gire o interruptor de velocidade de ventilador A/C no sentido horário.

Resultado:

O ar quente é soprado para fora.

- c) Quando a temperatura da água atingir 80°C.

O aquecedor de cabine para de funcionar automaticamente e a luz de controle “estado do aquecedor de cabine” apaga.

- d) Quando a temperatura da água for inferior a 65°C. O aquecedor de cabine funciona novamente.

Desse modo, o processo é repetido em círculos.

Quando o aquecedor de cabine for utilizado no frio pela primeira vez, examine os itens abaixo:

- Não há bloqueio na passagem de ar.
- O aquecedor de cabine opera suavemente.
- Não há sujidade na entrada de ar de combustão e saída de exaustão.

Quando o aquecedor de cabine não for utilizado, pressione o interruptor de alimentação do aquecedor de cabine na posição OFF para parar o aquecedor. Ao mesmo tempo, a luz de controle “estado do aquecedor de cabine” apagar após 3 minutos.



Figura 6-5 Luz de controle “estado de aquecedor de cabine”

AVISO

Desligue o aquecedor de cabine somente após a luz de controle “estado de aquecedor de cabine” apagar. Caso contrário, ocorrerá defeito no aquecedor de cabine, devido à falha de dissipação de calor.

6.2.2.4 Diagnóstico e solução de problemas relacionados com falhas comuns

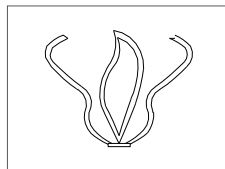
Tabela 6-7 Diagnóstico e solução de problemas relacionados com falhas comuns

Problemas	Causas	Reparação
O ar quente não é soprado para fora.	O interruptor de velocidade de ventilador A/C no painel de controle do ar condicionado não está ligado.	Ligue o interruptor de velocidade de ventilador A/C no painel de controle do ar condicionado.
O aquecedor de cabine não para de funcionar em até 60 segundos após o fornecimento de combustível é cortado.	A válvula solenoide está suja ou não pode ser fechada completamente, ou o detector de chamas está em curto-circuito.	Limpe o tubo de óleo e examine a conexão, a caixa de controle e detector de chamas.
A alimentação está instável.	A onda de fonte de alimentação é grande e instável.	Examine se a fonte de alimentação está estável (especialmente quando a fonte de alimentação estabilizada for aplicada), ou troque o painel de controle.
A tensão é alta.	A tensão do aquecedor de cabine é superior a 32 V por 5 segundos (para o aquecedor de cabine cuja tensão nominal for 12 V, significa que a tensão é superior a 16 V).	Verifique a tensão. Se a tensão for alta, verifique o regulador de tensão do motor. Se não for alta, troque a caixa de controle.
A tensão é baixa.	A tensão do aquecedor de cabine é inferior a 20 V por 5 segundos (para o aquecedor de cabine cuja tensão nominal for 12 V, significa que a tensão é inferior a 10 V)	Dê partida no motor e aquecedor de cabine e depois verifique o gerador e tensão de linha. Se a tensão não for alta, troque o painel de controle.
O detector de chamas estão em curto-circuito.	Quando o aquecedor de cabine não funcionar, o detector de chamas ainda mostra o estado de operação.	Verifique se a linha está em curto-circuito, troque o detector de chamas ou painel de controle.
Quando o relé do motor é desligado, ele ainda fica eletrificado.	O ponto de contato está conectado, ou o interruptor de controle está com defeito.	Troque o painel de controle.
O relé da válvula solenoide ainda fica eletrificado quando é desligado ou a bobina da válvula solenoide se rompe.	O ponto de contato está conectado, ou a bobina se rompe, ou o painel de controle está com defeito.	Troque o painel de controle ou sua bobina.
O fusível se rompe.	O fusível se rompe, o fio está desconectado, ou o painel de controle está com defeito.	Redefina o fusível, verifique a conexão ou troque o painel de controle.

Problemas	Causas	Reparação
Quando o relé da válvula solenoide está eletrificado, não consegue emitir sinais.	O painel de controle está danificado.	Troque o painel de controle.
Quando o relé do motor estiver eletrificado, não pode emitir sinais.	O relé ou painel de controle está com defeito.	Troque o painel de controle.
O motor não funciona	O motor principal não funciona após ser eletrificado ou a velocidade de rotação é baixa.	Verifique a conexão do motor. Retire o plugue para verificar o motor, se não funcionar ou a velocidade de rotação for baixa, troque o motor. Caso contrário, troque o painel de controle.
O sensor de temperatura de água está em curto-circuito.	Há água no sensor ou a placa do circuito está molhada.	Troque o sensor ou caixa de controle.
O circuito do sensor de temperatura de água quebra.	A linha do sensor se rompe ou a placa do circuito falha.	Troque o sensor ou caixa de controle.
O detector de chamas não dispara.	O detector de chamas não produz sinal de chama.	Verifique a conexão do detector de chamas, troque o detector ou painel de controle.
A chama apaga durante a queima.	A chama apaga durante a queima não queima de novo.	Se o houver pouco óleo no tanque de óleo, adicione mais. Se o tubo de óleo vazar, aperte ou troque. Troque o detector de chamas em curto-circuito e a caixa de controle.
Interferência forte	Outras interferências	Feche outra fonte de interferência, troque o painel de controle.
O plugue de ignição quebra.	O plugue de ignição queima ou a linha solta.	Aperte a conexão, troque o plugue de ignição.
O plugue de ignição está em curto-circuito.	Ela está em curto-circuito.	Verifique.
O relé do plugue de ignição não tem sinal de saída.	O relé ou painel de controle está com defeito.	Troque o painel de controle.

ZOOMLION

Manual do operador de caminhão guindaste

Capítulo 7 Transporte e armazenamento



Capítulo 7 Transporte e armazenamento

7.1 Transporte

É possível mover o guindaste por sua alimentação para condução rodoviária ou por outros transportadores, por uma longa distância.

Durante o transporte, escore as rodas e torne o guindaste seguro com cabos de arame. Feche totalmente as janelas e a porta, para manter a cuva e umidade fora da cabine. Trave a porta e janelas.

Siga esses itens a seguir antes do levantamento. É recomendado utilizar dispositivo especial de levantamento.

- Estenda quatro vigas deslizantes aproximadamente 4800 mm.
- Enrole as escoras com cabo de arame.
- O gancho está acima do centro de gravidade do veículo completo. Consulte a figura 7-1.



Figura 7-1 Pontos de levantamento



Antes de levantar, verifique se as eslingas têm resistência suficiente para segurar o guindaste.

72 Armazenamento

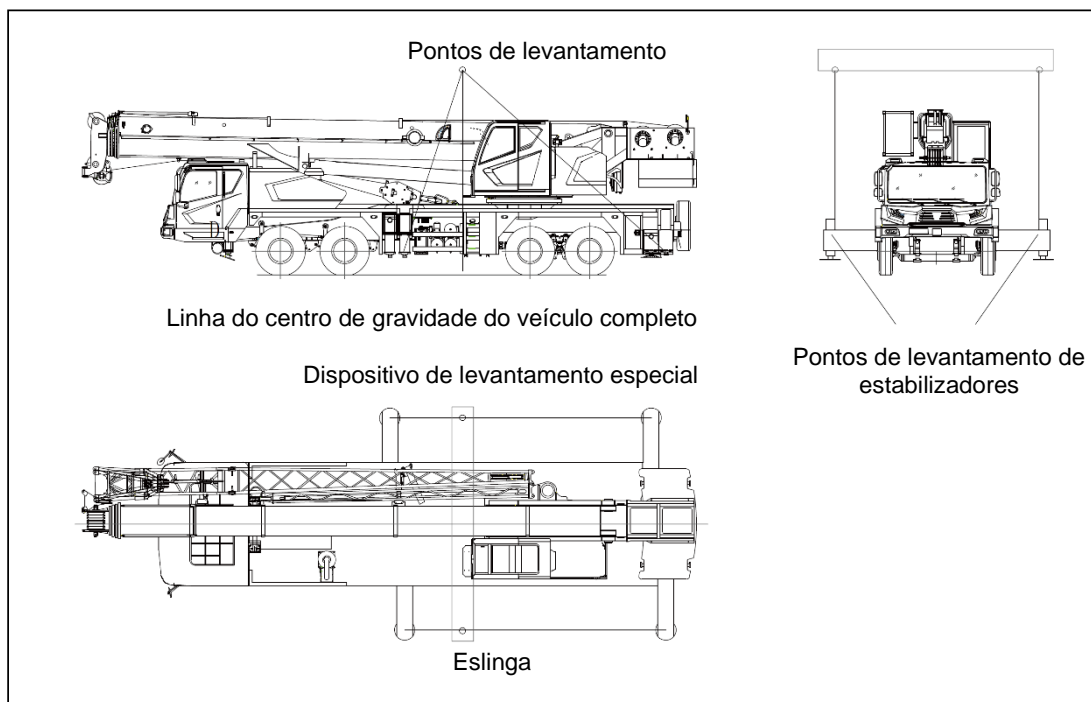
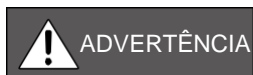
Siga os passos a seguir se não utilizar o guindaste por um longo tempo:

- a) Trave as portas e janelas e desligue os instrumentos de controle.
- b) Limpe a contaminação do guindaste.
- c) Retraia totalmente todos os pistões de cilindro (exceto cilindros verticais).
- d) Estenda totalmente os cilindros verticais para levantar os pneus do solo.
- e) Encha os pneus até a pressão especificada e coloque blocos de madeira abaixo dos pneus.
- f) Desligue o motor e o interruptor mestre de bateria.
- g) Se a bateria não for utilizada por mais de um mês, desconecte seu fio conector no sistema elétrico. Se o guindaste não for utilizado por um longo período de tempo, carregue a cada três meses.
- h) É necessário lubrificar as superfícies de todos os componentes metálicos expostos, para prevenir a corrosão.
- i) Remova toda a contaminação (poeira e areia) dos cabos de arame e lubrifique com graxa de grafite à base de cálcio ZG-3.
- j) Armazene o guindaste em uma garagem. Se não, proteja o guindaste contra chuva, raios e congelamento.
- k) Se não operar o guindaste por mais de três meses:
Opere o motor em velocidade sem carga por uma hora no intervalo de três meses.
- l) Se não operar o guindaste por mais de 18 meses:
 - 1) Mantenha o guindaste limpo e faça a manutenção usual.
 - 2) Troque componentes de vedação envelhecidos.
 - 3) Faça uma inspeção geral do motor, para verificar se é necessário trocar o fluido refrigerante, óleo diesel e filtros de ar.
- m) Certifique-se que uma pessoa mantenha o guindaste preparado para operação.