

WA7025-12

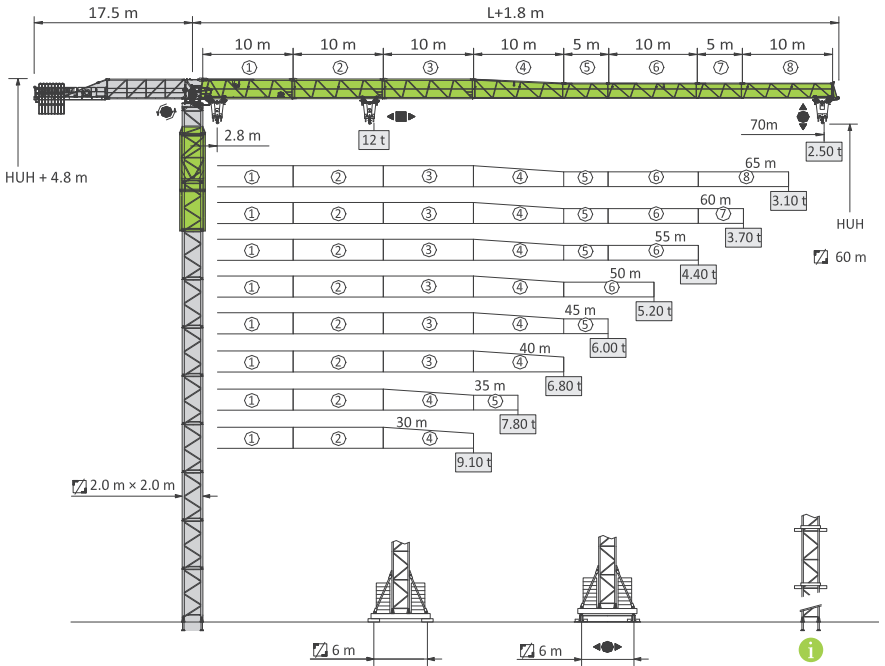

塔身-反力&附着 / Mast - Reactions & Anchorages / Torre - Reação & Fixação / Tramos- Reacciones y Arriostramientos

 2.0m - L68A WA7025-12E

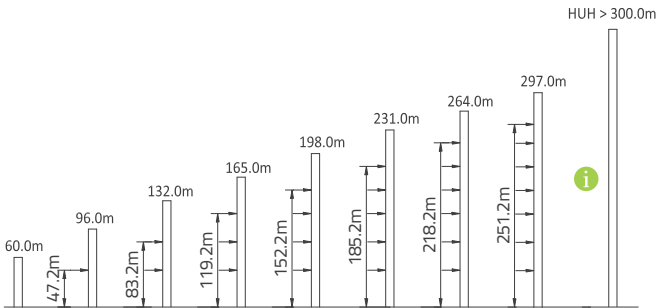
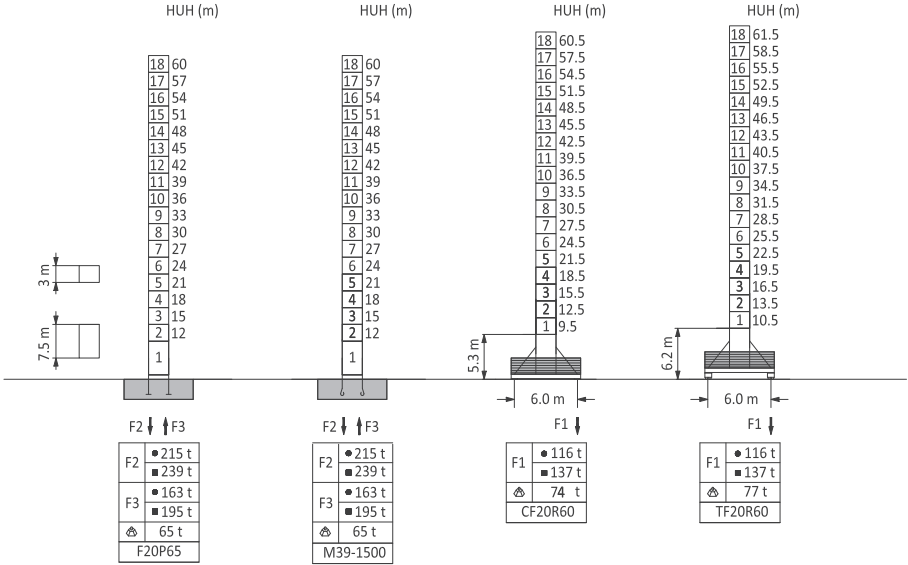







起重性能 / Load diagrams / Tabela de Carga / Diagrama de carga

lifting

m	m / t	Lifting capacity (t)																
		10.0	12.5	15.0	17.5	20.0	22.5	25.0	27.5	30.0	35.0	40.0	45.0	50.0	55.0	60.0	65.0	70.0
70.0	2.8-35.8/6	6.0	6.0	6.0	6.0	6.0	6.0	6.0	6.0	6.0	6.0	5.1	4.4	3.9	3.5	3.1	2.8	2.5
	2.8-19.7/12	12.0	12.0	12.0	12.0	11.5	10.0	8.8	7.9	7.1	5.9	5.0	4.4	3.8	3.4	3.0	2.7	2.4
65.0	2.8-38.7/6	6.0	6.0	6.0	6.0	6.0	6.0	6.0	6.0	6.0	6.0	5.7	4.9	4.3	3.8	3.4	3.1	
	2.8-21.3/12	12.0	12.0	12.0	12.0	12.0	11.0	9.7	8.7	7.9	6.6	5.6	4.8	4.2	3.8	3.3	3.0	
60.0	2.8-40.8/6	6.0	6.0	6.0	6.0	6.0	6.0	6.0	6.0	6.0	6.0	6.0	5.3	4.6	4.1	3.7		
	2.8-22.4/12	12.0	12.0	12.0	12.0	12.0	11.7	10.4	9.3	8.4	7.0	6.0	5.2	4.6	4.0	3.6		
55.0	2.8-42.8/6	6.0	6.0	6.0	6.0	6.0	6.0	6.0	6.0	6.0	6.0	6.0	5.6	4.9	4.4			
	2.8-23.4/12	12.0	12.0	12.0	12.0	12.0	12.0	11.0	9.8	8.9	7.4	6.4	5.5	4.9	4.3			
50.0	2.8-44.5/6	6.0	6.0	6.0	6.0	6.0	6.0	6.0	6.0	6.0	6.0	6.0	5.9	5.2				
	2.8-24.3/12	12.0	12.0	12.0	12.0	12.0	12.0	11.5	10.3	9.3	7.8	6.7	5.8	5.1				
45.0	2.8-45.0/6	6.0	6.0	6.0	6.0	6.0	6.0	6.0	6.0	6.0	6.0	6.0	6.0	6.0				
	2.8-25.0/12	12.0	12.0	12.0	12.0	12.0	12.0	11.9	10.7	9.7	8.1	6.9	6.0					
40.0	2.8-40.0/6	6.0	6.0	6.0	6.0	6.0	6.0	6.0	6.0	6.0	6.0	6.0						
	2.8-24.6/12	12.0	12.0	12.0	12.0	12.0	12.0	11.7	10.5	9.5	8.0	6.8						
35.0	2.8-35.0/6	6.0	6.0	6.0	6.0	6.0	6.0	6.0	6.0	6.0	6.0							
	2.8-24.2/12	12.0	12.0	12.0	12.0	12.0	12.0	11.5	10.3	9.3	7.8							
30.0	2.8-30.0/6	6.0	6.0	6.0	6.0	6.0	6.0	6.0	6.0	6.0	6.0							
	2.8-23.6/12	12.0	12.0	12.0	12.0	12.0	12.0	11.2	10.1	9.1								

传动机构 / Mechanisms / Mecanismo de transmissão / Mecanismos

380 V (± 10 %) 50 Hz		Lifting		Lifting		kW		
	H45FC30-600A	t	1.5	6	3	12	45	600 m 
		m/min	95	38	47.5	19		
	S75CA-130LB12/14A S75CN-130LB12/14A	r/min	0 - 0.8				2x7.5	
	T55FC70-b(D)	m/min	0 - 75				5.5	
	ZA52-D B52-D	m/min	0 - 25				2x5.2	
		65.5 kW + 2x5.2 kW						

平衡重 / Counter-jib ballast / Contrapeso / Contrapeso

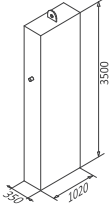
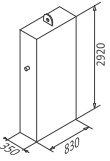
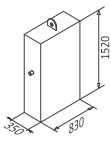
高度 (m)	3.0t	2.5t	1.3t	重量 (t)	PHZ3000R	PHZ2500T	PHZ1300P
70.0	4	3	1	20.8	 (mm)	 (mm)	 (mm)
65.0	4	3	0	19.5			
60.0	4	3	0	19.5			
55.0	4	3	0	19.5			
50.0	4	2	1	18.3			
45.0	3	3	1	17.8			
40.0	4	1	1	15.8			
35.0	3	2	0	14.0			
30.0	3	1	1	12.8			







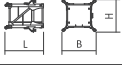

压重 / Base ballast / Lastro / Lastre basal

 2.0m - L68A	CB20R60	HUH (m)	21.5	24.5	27.5	30.5	33.5	36.5	39.5	42.5	45.5	48.5	51.5	54.5	57.5	60.5	
	TB20R60	HUH (m)	22.5	25.5	28.5	31.5	34.5	37.5	40.5	43.5	46.5	49.5	52.5	55.5	58.5	61.5	
	重量 (t)		51.6	51.6	51.6	51.6	60.6	60.6	69.6	69.6	69.6	78.6	78.6	87.6	87.6	105.6	105.6





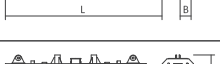
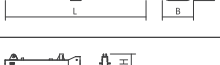

运输单元 / Dimensions and weight / Unidades de transporte / Unidã de transporte

上装 / Slewing crane part / Peça de guindaste girat3rio/Pieza de grúa giratoria		L (m)	B (m)	H (m)	kg (±5%)	
平衡臂 Counter-jib Contra Lança Braço de equilíbrio	 ①	11.0	1.27	2.49	3500	
	 ②	8.13	1.27	0.56	2150	
起重臂节 Jib section Juntas da lança Pluma Contrapeso	①	10.3	1.15	2.42	2600	
	②	10.3	1.15	2.42	1810	
	③	10.3	1.15	2.42	1370	
	④	10.3	1.15	2.42	1130	
	⑤	10.3	1.15	1.80	810	
	⑥	10.3	1.15	1.80	520	
	⑦	5.2	1.15	1.80	530	
	⑧	5.2	1.15	1.80	320	
	⑨	0.87	1.15	1.80	90	
载重小车 Trolley Carros de deslocamento Carro	 L B	2.10	1.87	1.04	400	
吊钩 Pulley block Gancho Gancho	 L H	1.07	0.36	1.80	530	
司机室 Cabin Cabine de operação Cabina	 L B H	2.08	1.30	2.16	480	
起升机构 Hoisting mechanism Mecanismo de elevação Mecanismo de izaje	 L B H	H45FC30-600C	2.00	1.07	0.88	1340
变幅机构 Trolleying mechanism Mecanismo de angulação Mecanismo de carro	 L B H	T55FC70-b(D)	1.20	0.73	0.59	480
回转总成 Slewing assembly Montagem girat3ria Conjunto de giro	 L B H	2.0 m	2.56	2.44	2.29	5290

运输单元 / Dimensions and weight / Unidades de transporte / Unidad de transporte

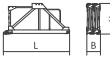
塔身 / Crane tower / Corpo da torre / Tramo		L (m)	B (m)	H (m)	kg (±5%)	
过渡节 Transition section Seções de transição Sección de transición		2.0 m - L68C3B	2.46	2.67	1770	
爬升架 Climbing tower section Quadro de escalada Jaula de telescopaje		2.0 m - TC25P50	7.23	2.64	3970	
标准节 (4片) Tower section (4 pieces) Secção padrão (4 comprimidos) Sección de torre (4 piezas)		2.0 m - L68A4	3.28	2.04	1610	
标准节 Tower section Secção padrão Sección de torre		2.0 m - L68G23	7.76	2.06	4190	
支腿 Fixing angles Chumbadores Empotramiento		F20P65	0.45	0.45	4×185	
底架基础节 Basic mast unit Secção base do quadro base Sección base para chasis		CF20R60 / TF20R60	4.5	2.37	4060	
撑杆 Border support Escoras Apoyo fronterizo		CF20R60 / TF20R60	5.2	0.19	0.29	4×422
整梁 Main beam Viga principal Te principal		CF20R60 / TF20R60	8.94	0.9	1.27	2180
半梁 Half beam Meia viga Media viga		CF20R60 / TF20R60	4.31	0.51	1.27	2×1056

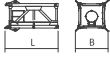
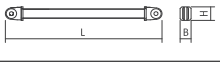
运输单元 / Dimensions and weight / Unidades de transporte / Unidad de transporte

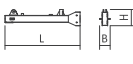
塔身 / Crane tower / O corpo da torre / Tramo		L (m)	B (m)	H (m)	kg (±5%)	
过渡节 Transition section Seções de transição Sección de transición		2.0 m - L68C3C	2.63	2.63	4.00	1571
爬升架 Climbing tower section Quadro de escalada Jaula de telescopaje		2.0 m - TC20P50U	7.23	3.36	1.27	1350
		2.0 m - TC20P50U	7.23	3.36	1.52	1810
标准节 (4片) Tower section (4 pieces) Seção padrão (4 comprimidos) Sección de torre (4 piezas)		2.0 m - L68A1A	3.28	2.04	0.70	1610
标准节 Tower section Seção padrão Sección de torre		2.0 m - L68G23-C	7.76	2.06	2.00	4194
支腿 Fixing angles Outriggers Empotramiento		F20P65	0.45	0.45	1.19	4×185
底座基础节 Basic mast unit Seção base do quadro base Sección base para chasis		CF20R60 / TF20R60	4.5	2.37	2.37	4060
撑杆 Border support Escoras Apoyo fronterizo		CF20R60 / TF20R60	5.2	0.19	0.29	4×422
整梁 Main beam Viga principal Te principal		CF20R60 / TF20R60	8.94	0.9	1.27	2180
半梁 Half beam Meia viga Media viga		CF20R60 / TF20R60	4.31	0.51	1.27	2×1056

